

L-1034
 REV B
 05/98
 PC-3220

DATE CODE NUMBERS BEGINNING WITH THE LETTER "B".

NOTE: Apply hydraulic sealant to threads of Items 6, 16, 18, 19 and 23.

Assemble adhesive side of gasket to base.

Set at 9,800-9,900 psi.

Tighten Item 21 with Item 20 so that it does not turn free.

Torque seats (Items 16 and 19) to 18-22 ft-lbs.

Set at 350 psi.

(S) Indicates staked threads. Remove stake mark prior to disassembly. Restake after testing repaired jack.

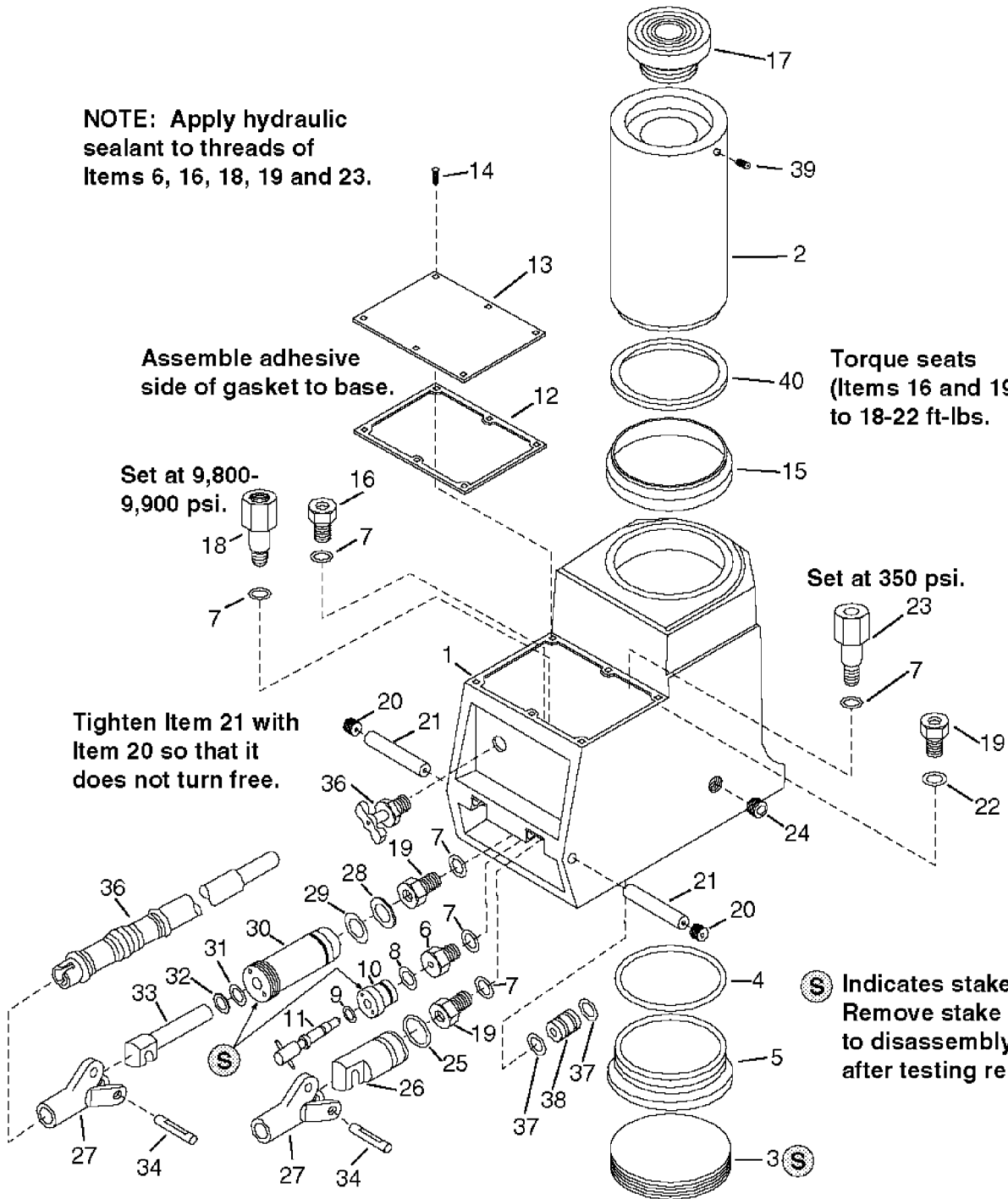

REPAIR PARTS LIST

Item No.	Part Number	Quantity	Description	Item No.	Part Number	Quantity	Description
1	CF134005	1	Base	21	CA48061	2	Beam Pin
2	CF143040	1	Plunger	22	★S1167	1	Gasket
3	CF648006	1	Outer Base Plug	23	C960900W	1	Bypass Valve
4	★B1435903	1	O-Ring	24	A1008245	1	Hex Plug
5	CL647006	1	Inner Base Plug	25	★B1212513	1	GT-Ring
6	CA86290	1	Seat	26	CB453051	1	Pump Plunger
7	★B159167	6	Gasket	27	Y918060	2	Beam
8	★B1224503	1	O-Ring	28	★B1117903	1	O-Ring
9	★B1003503	2	O-Ring	29	★B1117565	1	Back-Up Washer
10	Y845446	1	Sleeve	30	CA55446	1	Sleeve
11	CA237950W	1	Release Valve	31	★B1113803	1	O-Ring
12	★CA57167	1	Gasket	32	★B1113565	1	Back-Up Washer
13	CB131101	1	Cover Plate	33	CA364051	1	Piston
14	F866028	6	Machine Screw	34	P7557	2	Pin
15	★CF148044	1	Wiper Ring	35	CA561024	1	Drain Cock
16	CA376900W	1	Seat Assembly	36	CA298900SR	1	Handle Grip Assy.
17	Y4045	1	Saddle	37	★B1011803	2	O-Ring
18	P181190W	1	Relief Valve	38	CF146446	1	Sleeve
19	DA3041900SR	3	Seat Assembly	39	Y13028	1	Screw
20	Y990028	2	Set Screw	40	★CH796041	1	U-Cup

★ Items included in and available only as part of Repair Kit JHA-1506K2.
Kit also includes replacement decals.

Australia
ENERPAC
Applied Power Australia, Ltd.
P.O. Box 261 Regatta Park
Sydney, N.S.W. 2143
Tel: (61) (2) 9743 9398
Fax: (61) (2) 9743 9548

CIS
Applied Power Moscow
Leninsky Prospekt 95A
117319 Moscow, Russia
Tel: (7) (95) 995 5090
Fax: (7) (95) 995 2006

**France, Switzerland,
Turkey, Greece, Africa,
Middle East**
ENERPAC S.A.
Parc d'Activité du Moulin
de Massey
1 rue du Sauleloup, BP200
F-91892 Massey CEDEX
(Paris) France
Tel: (33) 1 60 13 68 68
Fax: (33) 1 69 20 37 50

**Germany, Scandinavia,
Eastern Europe, Austria,
Switzerland**
ENERPAC
Applied Power GmbH
P.O. Box 20 01 13
Mündelheimer Weg 51
40401 Düsseldorf 30
Germany
Tel: (49) (211) 47 14 90
Fax: (49) (211) 4714 928/940

**Holland, Belgium,
and Luxembourg**
ENERPAC B.V.
P.O. Box 263, Startkruis 25
3900 G. Veenendaal
Holland
Tel: (31) (318) 53 59 11
Fax: (31) (318) 52 55 13/53 56 45

Hong Kong
ENERPAC
Room No. 907, Workingberg
Commercial Building
41-47 Marble Road, North Point
Tel: (852) 561 8295
Fax: (852) 561 6712

India
ENERPAC
Hydraulics (India) Pvt Ltd
203 Vardhaman Chamber
Plot #84, Sector 17
Vashi, New Bombay 400 705
India
Tel: 91-22-7631062
Fax: 91-22-7670909

Italy
ENERPAC
Applied Power Italiana S.p.A.
Via Canova, 4
20094 Corsico (Milano)
Italy
Tel: 39 245 82744/23
Fax: 39 2 49 60 1288

Japan
Applied Power Japan LTD
10-17 Seamae Kita-cho
Toda-City
Saitama 335,
Japan
Tel: 81 048 422 2251
Telex: J28275
Fax: 81 048 422 0956

Mexico
ENERPAC
Applied Power Mexico S.A. de C.V.
Av. Principal La Paz #100
Free Industrial La Paz
42094 Padua, Hidalgo, Mexico
Tel: (52) 771 33700
Fax: (52) 771 83800

Singapore
Applied Power Asia Pte Ltd
47 Jalan Pemimpin #01-02
01-03 Sin Cheong Building
Singapore 2057
Thomas Road P.O. Box 114
Singapore 9157
Tel: (65) 238 4577
Fax: (65) 238 2847

South Korea
ENERPAC
Applied Power Korea Ltd.
#3-12, Doding-Dong
Wanmigu, Buchun-Shi
Kyunggi-Do
Korea
Tel: (82) (32) 67 50836
Fax: (82) (32) 67 53002

Spain, Portugal
ENERPAC
Applied Power International, S.A.
Calle de la Imprenta, 7
Polígono Industrial
28100 Alcobendas (Madrid)
Spain
Tel: (34) 1 661 11 25
Fax: (34) 1 661 47 89

United Kingdom, Ireland
ENERPAC Ltd Unit 3
Coleman Road
North Meads Moss
Redditch, Worcester B98 9BP
England
Tel: 44 01527 598 900
Fax: 44 01527 595 900

**United States, Canada,
Latin America and
Caribbean**
ENERPAC
2800 West Silver Spring Drive
Butler, Wisconsin 53007, USA
Tel: (414) 781-6600
1-800-426-2765 (End User)
1-800-558-0280 (Distributor)
Fax: (414) 781-4049

Canada
Tel: 1-800-426-4129 (End User)
Tel: 1-800-426-2284 (Distributor)

Latin America and Caribbean
Tel: (414) 781-6600 ext. 282
Fax: (414) 781-5961



All Enerpac products are guaranteed against defects in workmanship and materials for as long as you own them. Under this guarantee, free repair or replacement will be made to your satisfaction.

For prompt service, contact your Authorized Enerpac Service Center or call toll free:

In U.S.A. 1-800-658-0530

In Canada 1-800-426-2284