

L629 Rev. D 03/03

For Date Codes Beginning with the Letter "O"

Note: early production models used a plunger and saddle combination. This has been replaced by a 1-piece solid plunger design.

Note: Base, item 13, is not available as a service item. Order complete jack assembly.

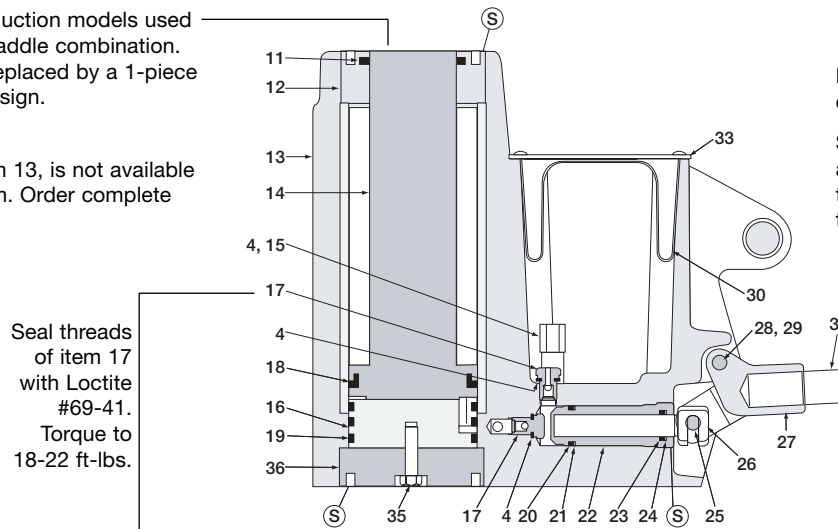

CAUTION: Indicates staked threads. Stake mark must be removed prior to disassembly. Failure to do so may result in damage to parts.

Some cylinder stop rings are assembled with Loctite material on threads. Enerpac suggests staking threads when reassembling.

Figure 1

Repair Parts List for Figure 1

Item	JHA-156 Part No.	JHA-356 Part No.	Qty.	Description
4	★ B159167	★ B159167	5	Gasket
11	★ CF296044	★ CA304044	1	Wiper Ring
12	CA267044	G91044	1	Stop Ring
13	Not a service item. Order complete Jack.			Base
14	CR700040	CR707040	1	Plunger
15	P181190W	P181190W	1	Relief Valve
16	CB142006	CB128006	1	Piston Plug
17	DA3041900SR	DA3041900SR	2	Seat Assembly
18	★ B1326513	★ B1334513	1	G T Assembly
19	★ B1133903	★ B1149903	3	O-Ring
20	★ B1117903	★ B1117903	1	O-Ring
21	★ B1117565	★ B1117565	1	Back-up Washer
22	CA55446SR	CA55446SR	1	Piston Sleeves (incl. items 20, 21, 23, 24, 26)
23	★ B1113803	★ B1113803	1	O-Ring
24	★ B1113565	★ B1113565	1	Back-up Washer
25	P7557	P7557	1	Drive Pin
26	See item 22.	See item 22.	1	Pump Plunger
27	Y918060	Y918060	1	Beam
28	Y991061SR	Y991061SR	1	Beam Pin
29	Y991061SR	Y991061SR	1	Set Screw
30	CR706025	CR708025	1	Bladder
33	CB127101	CB130101	1	Cover Name Plate
35	B1458046	B1458046	1	Hex Head Screw 1/4-20 x 1" Lg.
36	CB141006	CB129006	1	Base Plug
37	CA298900SR	CA298900SR	1	Handle and Grip Assembly

★ Items included in and available only as part of Repair Kit JHA-156K or JHA-356K.

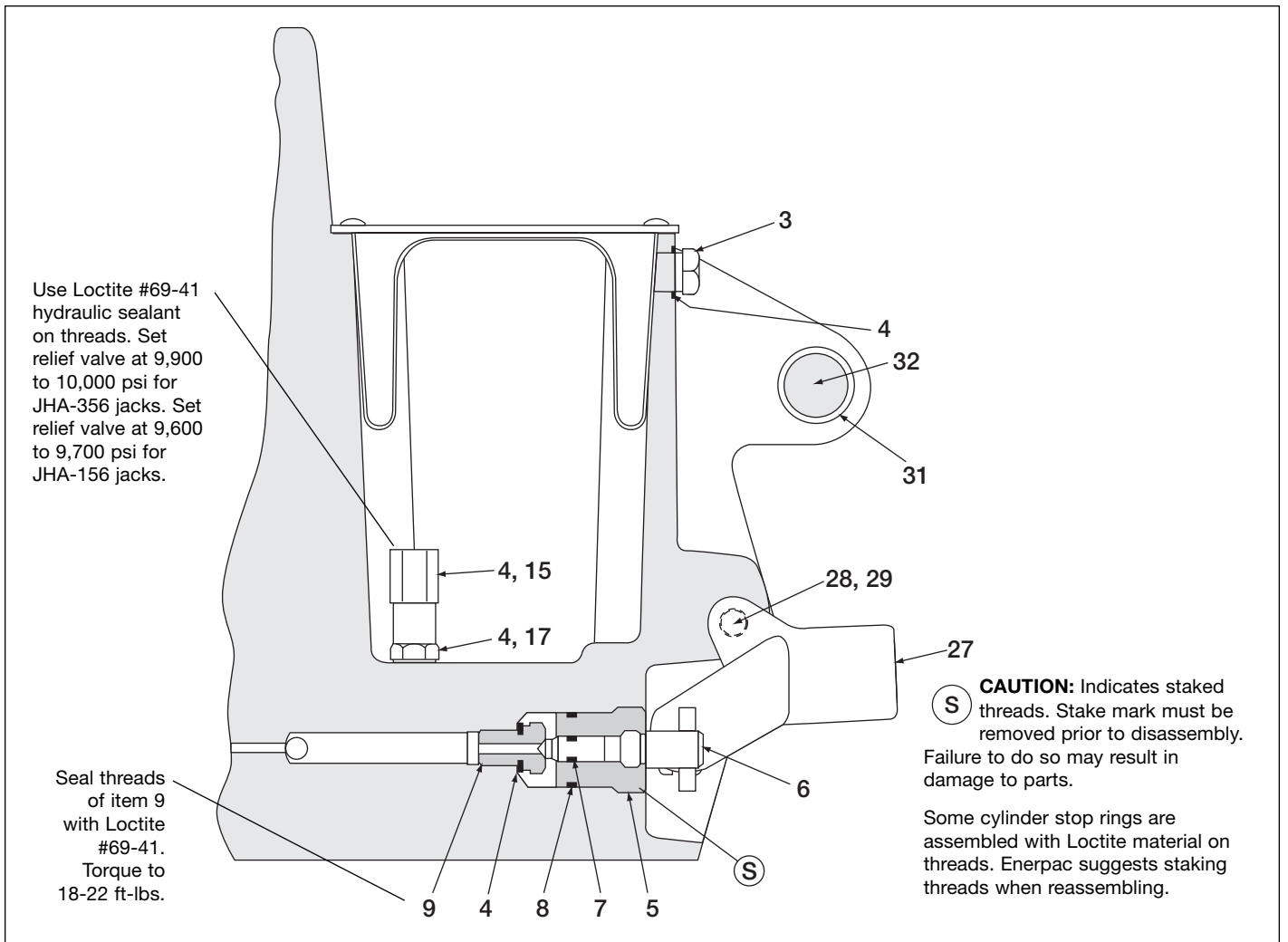

Figure 2, Section View B-B

Repair Parts List for Figure 2, Section B-B				
Item	JHA-156 Part No.	JHA-356 Part No.	Qty.	Description
3	CA113006SR	CA113006SR	1	Breather Filler Plug (incl. item 4)
4	★ B159167	★ B159167	5	Gasket
5	Y845446SR	Y845446SR	1	Release Assembly (incl. item 4, 6, 7, 8, 9)
6	See item 5	See item 5	1	Release Valve Assembly
7	★ B1003503	★ B1003503	1	O-ring
8	★ B1224503	★ B1224503	1	O-ring
9	CA86290	CA86290	1	Seat
15	P181190W	P181190W	1	Relief Valve
17	DA3041900SR	DA3041900SR	2	Seat Assembly
27	Y918060	Y918060	1	Beam
28	Y991061SR	Y991061SR	1	Beam Pin
29	Y991061SR	Y991061SR	1	Set Screw
31	★ CA282044	★ CA306044	2	Retaining Ring
32	CA281070	CA305070	1	Handle

★ Items included in and available only as part of Repair Kit JHA-156K or JHA-356K.

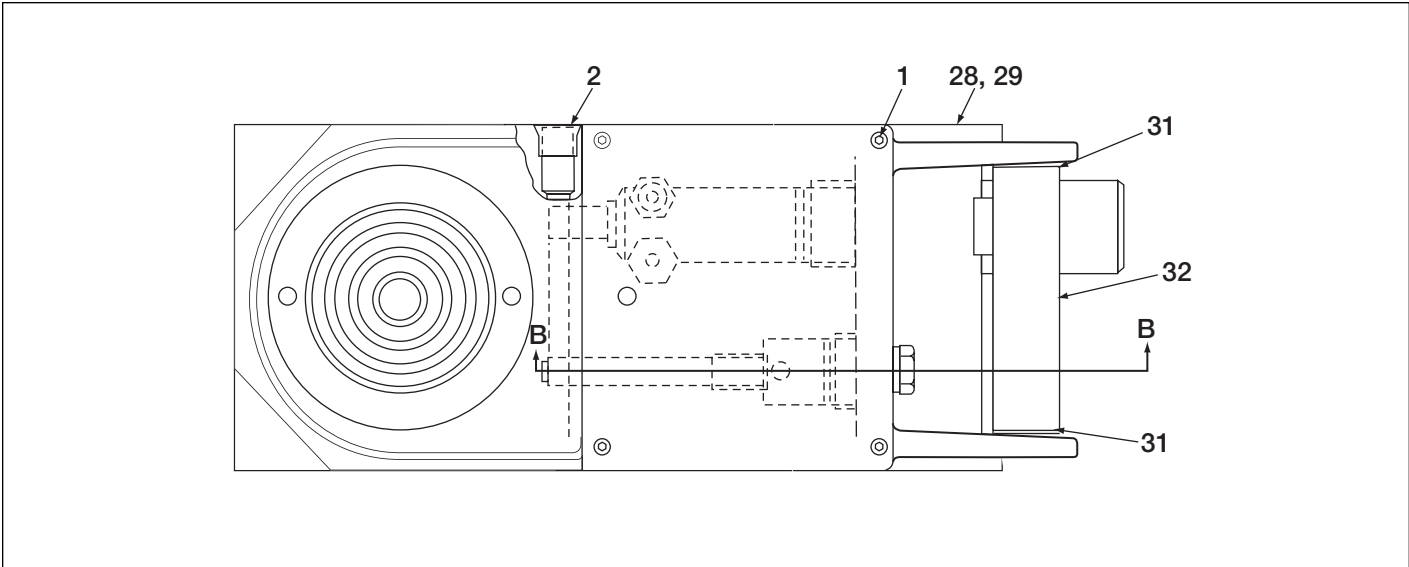

Figure 3

Repair Parts List for Figure 3				
Item	JHA-156 Part No.	JHA-356 Part No.	Qty.	Description
1	F866028	F866028	4	Button Hd. Soc. #10-24 x .5" Lg.
2	A1008245	A1008245	1	Flush Plug .250 NPT
28	Y991061SR	Y991061SR	1	Beam Pin
29	Y991061SR	Y991061SR	1	Set Screw
31	★ CA282044	★ CA306044	2	Retaining Ring
32	CA281070	CA305070	1	Handle

★ Items included in and available only as part of Repair Kit JHA-156K or JHA-356K.

Enerpac Worldwide Locations

Australia

ENERPAC, Applied Power
Australia Ltd.
Block V Unit 3
Regents Park Estate
391 Park Road
Regents Park NSW 2143
(P.O. Box 261) Australia
Tel: +61 297 438 988
Fax: +61 297 438 648

Brazil

Power Packer do Brasil Ltda.
Rua dos Inocentes, 587
04764-050 - Sao Paulo (SP)
Tel: +55 11 5687 2211
Fax: +55 11 5686 5583
Toll Free in Brazil:
Tel: 000 817 200 6718
vendasbrasil@enerpac.com

Canada

Actuant Canada Corporation
6615 Ordan Drive, Unit 14-15
Mississauga, Ontario L5T 1X2
Tel: +1 905 564 5749
Fax: +1 905 564 0305

Toll Free:

Tel: +1 800 268 4987
Fax: +1 800 461 2456

Technical Inquiries:

techservices@enerpac.com

China

Actuant China Ltd.
1F, 269 Fute N. Road
Waigaoqiao Free Trade Zone
Pudong New District
Shanghai, 200 131 China
Tel: +86 21 5866 9099
Fax: +86 21 5866 7156

Actuant China Ltd. (Beijing)
709A Xin No. 2
Diyang Building
Dong San Huan North Rd.
Beijing City, 100028 China
Tel: +86 10 845 36166
Fax: +86 10 845 36220

Eastern Europe

Applied Power International S.A.
Case postale 130
CH-1213 Onex-Genève
Switzerland
Tel: +49 (211) 47149 44
Fax: +49 (211) 47149 40

France, Greece, Africa

ENERPAC S.A.
B.P. 200
Parc d'Activités
du Moulin de Massy
F-91882 Massy CEDEX
(Paris) France
Tel: +33 1 601 368 68
Fax: +33 1 692 037 50

Germany, Austria

ENERPAC
Applied Power GmbH
P.O. Box 300113
D-40401 Düsseldorf
Germany
Tel: +49 211 471 490
Fax: +49 211 471 49 28

India

ENERPAC Hydraulics
(India) Pvt. Ltd.
Plot No. A/571
MIDC, TTC Industrial Area
Mahape-400 701
Navi Mumbai, India
Tel: +91 22 778 1779
Fax: +91 22 778 1473

Italy

ENERPAC
Applied Power Italiana S.p.A.
Via Canova 4
20094 Corsico (Milano)
Tel: +39 02 4861 111
Fax: +39 02 4860 1288

Japan

Applied Power Japan Ltd.
1-1-11, Shimomae
Toda-shi
Saitama Pref.
Japan 335-0016
Tel: +81 48 430 2311
Fax: +81 48 430 1117

◆ e-mail: info@enerpac.com

Mexico

ENERPAC Applied Power
Mexico S. de R.L. de C.V.
Avenida Principal
La Paz #100
Fracc. Industrial La Paz
42092 Pachuca, Hidalgo
Tel: +52 771 71851 60
+52 771 71870 22
Fax: +52 771 71352 32
Toll Free in Mexico:
Tel: 001 800 590 0130

The Netherlands, Belgium, Luxembourg, Sweden, Denmark, Norway, Finland

ENERPAC B.V.
Storkstraat 25
P.O. Box 269, 3900 AG Veenendaal
The Netherlands
Tel: +31 318 535 911
Fax: +31 318 525 613
+31 318 535 848

Russia and CIS (excl. Caspian Sea Countries)

ENERPAC
Leninsky Prospect 95A
117313, Moscow, Russia.
Tel/Fax: +7(095) 936-2005
Tel/Fax: +7(095) 198-3094
Tel/Fax: +7(095) 938-4655
Mobil: +7(903) 731-9558

Singapore

Actuant Asia Pte. Ltd.
25 Serangoon North Ave. 5
#03-01 Keppel Dighub
Singapore 554914
Thomson Road
P.O. Box 114
Singapore 915704
Tel: +65 64 84 5108
+65 64 84 3737
Fax: +65 64 84 5669

South Korea

ENERPAC
Applied Power Korea Ltd.
163-12 Dodang-Dong
Wonmi-Ku, Buchun-shi
Kyunggi-Do
Republic of Korea
Tel: +82 32 675 08 36
Fax: +82 32 675 30 02/73

◆ internet: www.enerpac.com

Spain, Portugal

ENERPAC
C/San José Artesano 8
Pol. Ind.
28108 Alcobendas
(Madrid) Spain
Tel: +34 91 661 11 25
Fax: +34 91 661 47 89

Middle East, Turkey and Caspian Sea

ENERPAC Middle East FZE
P.O. Box 18004
Jebel Ali, Dubai
United Arab Emirates
Tel: +971 (0)4 8872686
Fax: +971 (0)4 8872687

United Kingdom, Ireland

ENERPAC Ltd., P.O. Box 33
New Romney, TN28 8QF
United Kingdom
Tel: +44 01527 598 900
Fax: +44 01527 585 900

USA, Latin America and Caribbean

ENERPAC
P.O. Box 3241
6100 N. Baker Road
Milwaukee, WI 53209 USA
Tel: +1 262 781 6600
Fax: +1 262 783 9562

User inquiries:

+1 800 433 2766

Distributor inquiries/orders:

+1 800 558 0530

Technical Inquiries:

techservices@enerpac.com

All Enerpac products are guaranteed against defects in workmanship and materials for as long as you own them.
For your nearest authorized Enerpac Service Center, visit us at www.enerpac.com