

Enerpac CATS

Tilt Saddles

Document Number: L4596

Document Revision: B

Document Revision Date: NOV-2022

Document Language: ENGLISH EN



To reduce the risk of injury, user must read and understand this document before use.

ABOUT US

Enerpac is a global market leader in high pressure hydraulic tools, controlled force products, portable machining, on-site services and solutions for precise positioning of heavy loads. As a leading innovator with a 110-year legacy, Enerpac has helped move and maintain some of the largest structures on earth. When safety and precision matters, elite professionals in industries such as aerospace, infrastructure, manufacturing, mining, oil & gas and power generation rely on Enerpac for quality tools, services and solutions. For additional information, visit www.enerpac.com.



www.facebook.com/enerpac



www.youtube.com/enerpac



www.linkedin.com/company/enerpac



www.twitter.com/enerpac

WARRANTY

Refer to the Enerpac Global Warranty document for terms and conditions of the product warranty. Such warranty information can be found at www.enerpac.com.

Contents

1. SAFETY	3
1.1 SAFETY PRECAUTIONS	3
2. COMPLIANCE STATEMENT	5
2.1 EU DECLARATION OF CONFORMITY	5
3. FEATURES & COMPONENTS	5
3.1 FEATURE DIAGRAM	5
4. TECHNICAL PRODUCT DATA.....	6
4.1 DIMENSIONAL CALLOUT ART	6
4.2 DIMENSIONAL TABLE	7
4.3 PRODUCT DESCRIPTION	8
4.4 TILT SADDLE CAPABILITIES.....	8
5. SET UP.....	8
5.1 INITIAL SETUP	8
6. INSPECTION, MAINTENANCE & STORAGE	8
7. PARTS LIST	9
7.1 INTERNAL VIEW	9
7.2 TABLE OF PARTS.....	11

1. Safety

Read all instructions carefully. Follow all recommended safety precautions to avoid personal injury as well as damage to the product and / or damage to other property. Enerpac cannot be responsible for any damage or injury from unsafe use, lack of maintenance, or incorrect operation. Do not remove warning labels, tags, or decals. In the event that any questions or concerns arise, contact Enerpac or a local Enerpac distributor for clarification.

Save these instructions for future use.

If you have never been trained on high-pressure hydraulic safety, consult your distributor or service center for information about Enerpac Hydraulic Safety Courses.

This manual follows a system of safety alert symbols, signals, words, and safety messages to warn the user of specific hazards. Failure to comply with these warnings could result in death or serious personal injury, as well as damage to the equipment or other property.



The Safety Alert Symbol appears throughout this manual. It is used to alert you to potential physical injury hazards. Pay close attention to Safety Alert Symbols and obey all safety messages that follow this symbol to avoid the possibility of death or serious injury.

Safety Alert Symbols are used in conjunction with certain Signal Words that call attention to safety messages or property damage messages and designate a degree or level of hazard seriousness. The Signal Words used in this manual are DANGER, WARNING, CAUTION, and NOTICE.

▲ DANGER Indicates a hazardous situation that, if not avoided, will result in death or serious personal injury.

▲ WARNING Indicates a hazardous situation that, if not avoided, could result in death or serious personal injury.

▲ CAUTION Indicates a hazardous situation that, if not avoided, could result in minor or moderate personal injury.

NOTICE Indicates information considered important, but not hazard related (e.g. messages related to property damage). Please note that the Safety Alert Symbol will not be used with the signal word.

1.1 Safety Precautions

▲ WARNING

Failure to observe and comply with the following precautions could result in death or serious personal injury. Property damage could also occur.

- Always wear protective head-wear, ear protectors, footwear and gloves (at a minimum rigger type gloves) suitable for safe operation of the tool. The protective clothing must not interfere with safe operation of the tool or restrict the ability to communicate with co-workers.
- Be sure your workplace is safe. Follow the instructions in your workplace's standard operating procedures and be sure to observe all communicated safety precautions.
- Be sure setup is stable before moving load.
- Always perform a visual inspection of the tilt saddle before placing it into operation. If any problems are found, do not use it. Have the tilt saddle repaired and tested by an Enerpac Authorized Service Center before it is returned to service.
- Never apply more hydraulic force to the tilt saddle than the maximum allowable force as stated in the manufacturer's specifications.
- Be sure the operator has completed safety induction training, specific to the work surroundings. The operator should be thoroughly familiar with the controls and the proper use of the tool.
- The operator must be of at least the minimum age required by applicable local regulations, laws and the facility standard operating procedures.

▲ CAUTION

Failure to observe and comply with the following precautions could result in minor or moderate personal injury. Property damage could also occur.

- For optimum performance, do not expose hydraulic equipment to temperatures of 150°F [65°C] or higher. Protect all hydraulic equipment from weld spatter.
- Immediately replace worn or damaged parts with genuine Enerpac parts. Enerpac parts are designed to fit properly and to withstand high loads. Non-Enerpac parts may break or cause the product to malfunction.

NOTICE

Failure to observe and comply with the following precautions could result in property damage and/or void the product warranty.

- In severe service conditions, be aware that the tilt saddle must be inspected, cleaned and lubricated more frequently than normal.
- Hydraulic equipment must only be serviced by a qualified hydraulic technician. For repair service, contact the Enerpac Authorized Service Center in your area.

2. Compliance Statement

2.1 EU Declaration of Conformity



Enerpac declares that this product has been tested and conforms with applicable standards and is compatible to all EU and UK Requirements.

Copies of the EU Declaration as well as the UK Declaration are enclosed with each shipment.

3. Features & Components

3.1 Feature Diagram

1. Lower saddle
2. Upper saddle
3. Upper screw
4. Lower screw

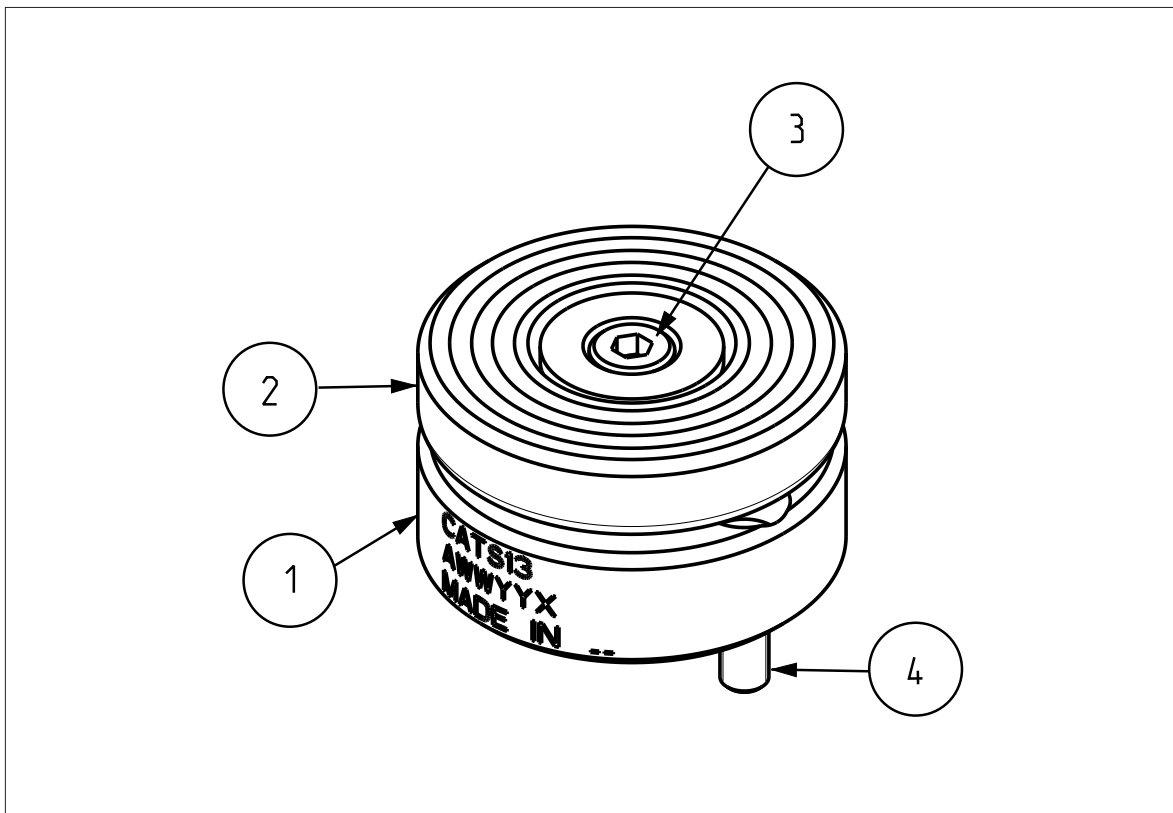

Figure 1: Major features and components of CATS (example model CATS13)

4. Technical Product Data

4.1 Dimensional Callout Art

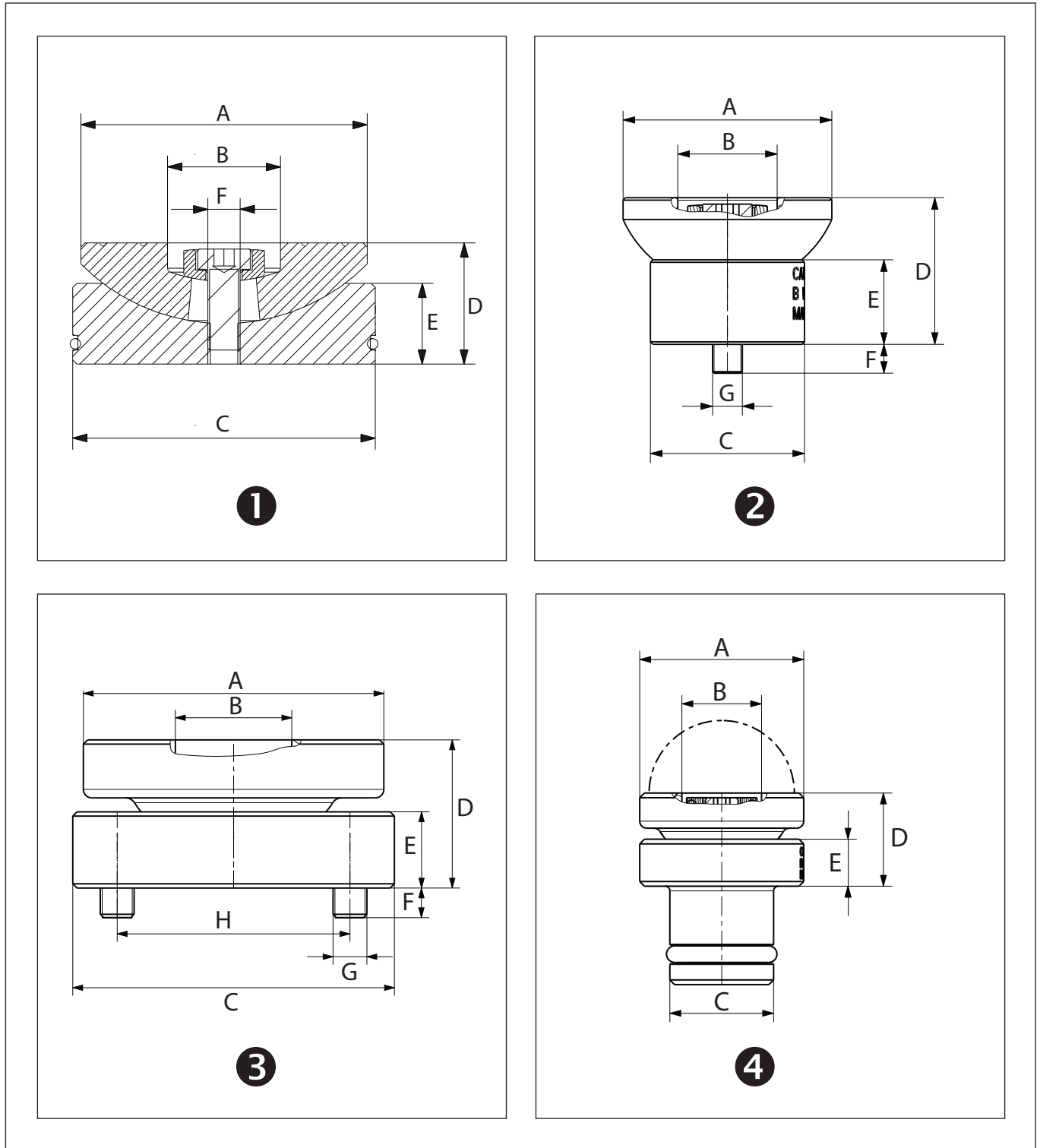

Figure 2: Tilt saddle dimensions

4.2 Dimensional Table

4.2.1 Dimensional table 1

Model	∅ A		∅ B		∅ C		D		E		F
	mm	in	mm	in	mm	in	mm	in	mm	in	
CATS100	71	2.80	28	1.10	71.5	2.81	30	1.18	20	0.79	M8
CATS101	71	2.80	28	1.10	75	2.95	30	1.18	20	0.79	M8

4.2.2 Dimensional table 2

Model	∅ A		∅ B		∅ C		D		E		F		G
	mm	in	mm	in	mm	in	mm	in	mm	in	mm	in	
CATS20	42	1.65	20	0.79	31	1.22	29.5	1.16	17	0.67	5.8	0.23	M6
CATS30	55	2.17	22	0.87	41	1.61	30.5	1.20	17	0.67	5.3	0.21	M6
CATS50	71	2.80	28	1.10	50	1.97	34	1.34	20	0.79	9	0.35	M12
CATS150	97	3.82	45	1.77	94	3.70	39.2	1.54	29	1.14	9	0.35	M12
CATS200	126	4.96	55.5	2.19	113	4.45	43	1.69	30	1.18	8	0.31	M12
CATS201	126	4.96	55.5	2.19	130	5.12	43	1.69	30	1.18	8	0.31	M12
CATS300	175	6.89	78	3.07	139	5.47	68.5	2.70	43	1.69	13	0.51	M12
CATS400	210	8.27	86	3.39	159	6.26	78	3.07	46.5	1.83	18	0.71	M16
CATS500	230	9.06	90	3.54	179	7.05	78	3.07	49	1.93	16	0.63	M16
CATS600	250	9.84	101	3.98	194	7.64	83	3.27	49	1.93	15	0.59	M16
CATS800	275	10.83	105	4.13	224.5	8.84	86.5	3.41	52	2.05	15	0.59	M16
CATS1000	300	11.81	112	4.41	249.5	9.82	107.1	4.22	65	2.56	15	0.59	M16
CATS301R	175	6.89	78	3.07	177	6.97	68.5	2.70	43	1.69	13	0.51	M12
CATS401R	210	8.27	86	3.39	196	7.72	78	3.07	46.5	1.83	18	0.71	M16
CATS501R	230	9.06	90	3.54	228	8.98	78	3.07	49	1.93	16	0.63	M16
CATS601R	250	9.84	101	3.98	247	9.72	83	3.27	49	1.93	15	0.59	M16
CATS801R	275	10.83	105	4.13	297	11.69	86.5	3.41	52	2.05	15	0.59	M16
CATS1001R	300	11.81	112	4.41	323	12.72	107.1	4.22	65	2.56	15	0.59	M16

4.2.3 Dimensional table 3

Model	∅ A		∅ B		∅ C		D		E		F		G
	mm	in	mm	in	mm	in	mm	in	mm	in	mm	in	
CATS13	35	1.38	17	0.67	38	1.50	20.3	0.80	11	0.43	7	0.28	M4
CATS53	50	1.97	22	0.87	65	2.56	26.1	1.03	15	0.59	5.5	0.22	M5
CATS103	71	2.80	27.5	1.08	76	3.00	35	1.38	18	0.71	7	0.28	M8

4.2.4 Dimensional table 4

Model	∅ A		∅ B		∅ C		D		E	
	mm	in	mm	in	mm	in	mm	in	mm	in
CATS12	35	1.38	17	0.67	22.1	0.87	19.9	0.78	10	0.39
CATS52	50	1.97	22	0.87	35.6	1.40	24.7	0.97	15	0.59

4.3 Product description

Enerpac hydraulic cylinders are built to ensure efficient and safe use time after time. But even the toughest cylinders can be damaged by an excessive side load, often with the user completely unaware it is happening.

Side loading can occur even when the load is vertically placed on top of the cylinder, when cylinders are extended too far (especially long stroke cylinders), or when the saddle on the end of the plunger fails to make sufficient contact with the load.

To help reduce the effects of side load, use of the CATS Series tilt saddle is strongly recommended.

The CATS series tilt saddle helps compensate for initial misalignment of the load and the cylinder surface. It reduces saddle edge loading, which can result in an undesirable off-center load being applied to the plunger.

4.3.1 Innovations

Enerpac's Tilt Saddles, which replace the CAT and CATG products, bring the following additional benefits:

- With safety and convenience in mind, CATS tilt saddles are designed to allow bolting to the cylinder – which means they can be used safely in any orientation without the risk of the saddle dropping off.
- The new CATS tilt saddles have up to 41% reduced collapsed height as compared with the outgoing CAT and CATG models. This enables use in lower-clearance situations.
- CATS Tilt Saddles use a nitrocarburization surface treatment for improved corrosion protection, helping to maintain a professional look through their usage life.
- Expanded coverage: Tilt saddles now available for use with smaller 20 & 30-ton aluminum cylinders.

Tilt Saddles are a readily available option that can be specified to work with a wide range of Enerpac cylinders to extend the life of the cylinders. Refer to Section 4.4 for additional information about CATS compatibilities.

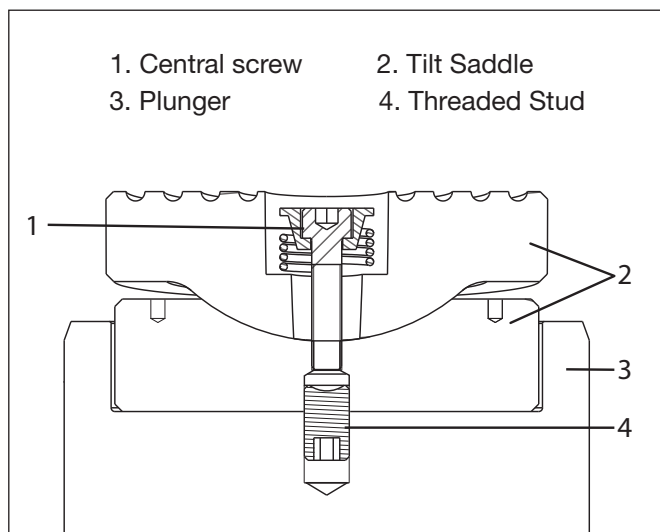

Figure 3: CATS Tilt Saddle Set Up

4.4 Tilt Saddle Specifications

CATS SPECIFICATIONS		
Model	Maximum load (KN)	Cylinder series compatibility
CATS12	142	RC, RR
CATS52	295	RC, RR
CATS13	101	RCS
CATS53	435	RCS
CATS103	887	RCS
CATS20	218	RAR
CATS30	309	RAC, RAR
CATS50	550	RAC, RAR, HCG, HCR
CATS100	1,002	RC, RR, HCL
CATS101	1,002	RAR, HCG, HCR
CATS150	1,497	RAC, HCG, HCR
CATS200	2,157	RAC, RAR, HCG, HCR
CATS201	2,157	HCL
CATS300	3,037	HCL, HCG, HCR
CATS400	4,008	HCL, HCG, HCR
CATS500	5,114	HCL, HCG, HCR
CATS600	5,987	HCL, HCG, HCR
CATS800	8,149	HCL, HCG, HCR
CATS1000	10,644	HCL, HCG, HCR
CATS301R	3,037	CLRG, CLSG, HCR, HCG
CATS401R	4,008	CLRG, CLSG, HCR, HCG
CATS501R	5,114	CLRG, CLSG, HCR, HCG
CATS601R	5,987	CLRG, CLSG, HCR, HCG
CATS801R	8,149	CLRG, CLSG, HCR, HCG
CATS1001R	10,644	CLRG, CLSG, HCR, HCG

5. Set Up

5.1 Initial Set Up

Refer to the following steps before installing the tilting saddle:

1. Remove the existing center bolt and standard saddle from the plunger bore (if equipped).
2. Inspect the mating surfaces of the plunger bore and the tilt saddle lower half. Mating surfaces must be free of dust, dirt, moisture or corrosion.

NOTICE Once installed, loosen the screw one turn to allow tilting.

5.1.1 CATS with O-ring

Install the tilt saddle as described in the following steps. Refer to Figure 3 for installation details.

1. Push down the center screw to install the tilt saddle on the plunger. The central screw is glued with loctite.

NOTICE To allow movement, do not lock the central screw.

NOTICE To uninstall the saddle, remove the central screw and insert a longer one. As the longer screw is threaded in, it stops at the bottom and pushes the piece up.

5.1.2 CATS with Central Screw

Install the tilt saddle as described in the following steps. Refer to Figure 3 for installation details.

1. By hand, gently engage the threads of the threaded stud with the threads of the tapped hole at the center of the plunger. Check for free movement. Be sure the stud is not cross-threaded.
2. Rotate the tilt saddle clockwise several turns, until it is fully seated in the plunger bore.

WARNING To prevent the threaded stud from breaking, be sure to screw the tilt saddle all the way in so that the lower part contacts the plunger.

5.1.3 CATS with Two Screws

Install the tilt saddle as described in the following steps. Refer to Figure 3 for installation details.

1. Fasten the lower part of the saddle with the two threaded bolts.
2. Once the lower part is fixed, place the upper part with the central screw.

6. Inspection, Maintenance & Storage

Periodically check the tilt saddle for free movement. If required, disassemble, clean and lubricate the tilt saddle. Use white lithium grease.

7. Parts List

Product Date Code Beginning With: A

7.1 Internal View

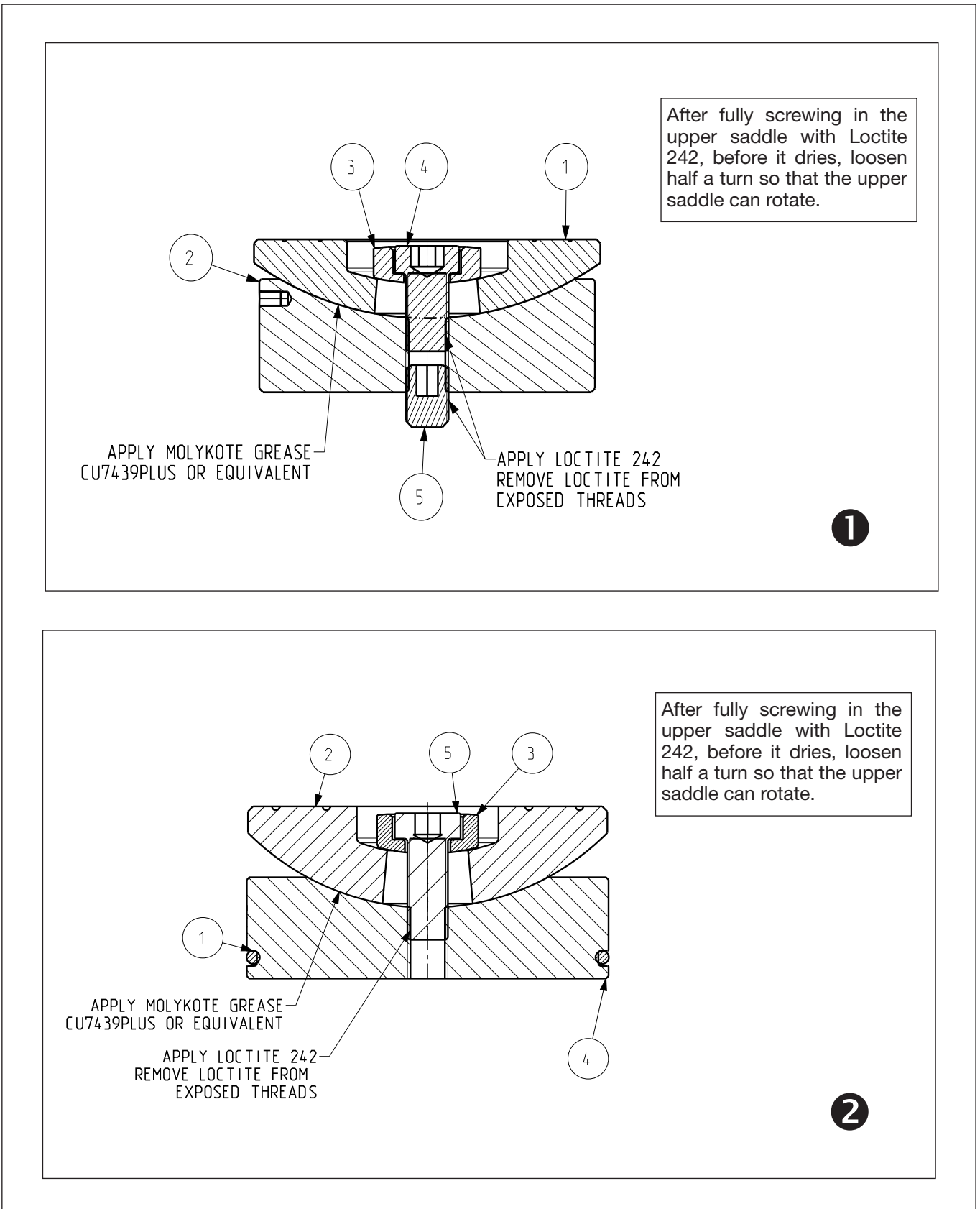
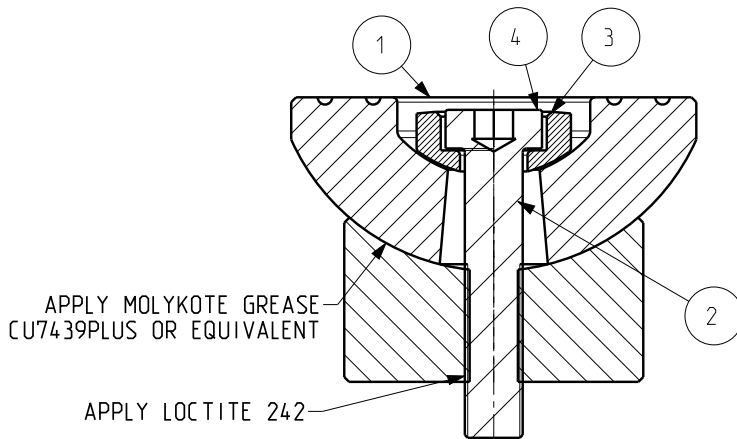
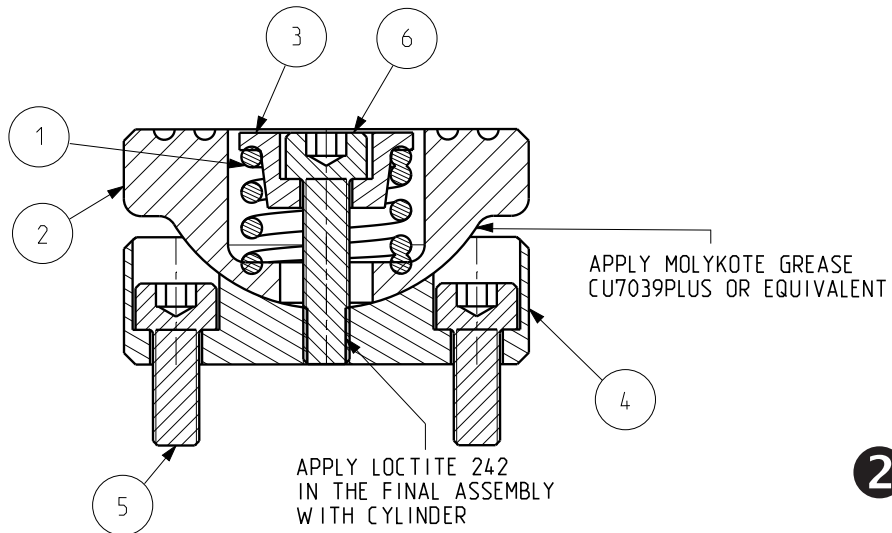

Figure 4: Tilt Saddles Internal View



After fully screwing in the upper saddle with Loctite 242, before it dries, loosen half a turn so that the upper saddle can rotate.

1



2

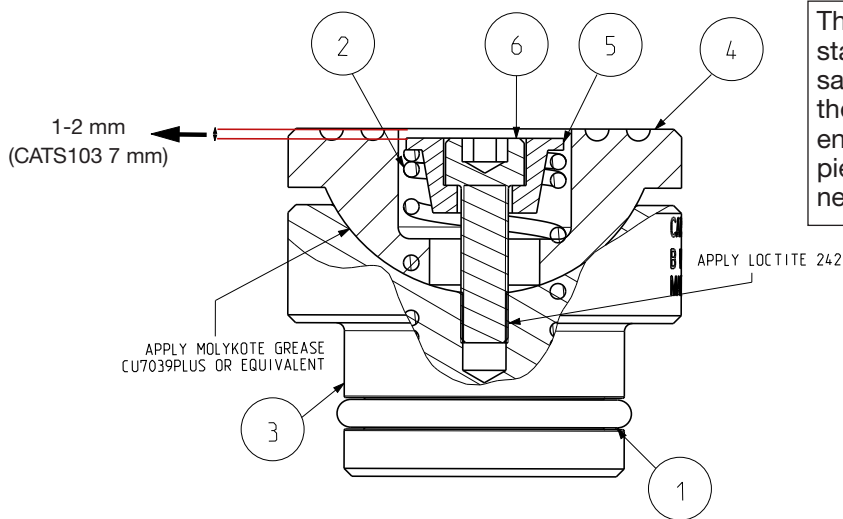

The spring guide can never stand out of the upper saddle. After fully tightening the screw, check there is enough distance from both pieces when tilting. Adjust if necessary.

3

Figure 5: Tilt Saddles Internal View

7.2 Table of Parts

Repair Parts List - Figure 4-1							
Item	Description	Qty.	Part number				
			CATS50	CATS150	CATS200	CATS201	CATS300
1	Upper saddle	1	N/A	N/A	N/A	N/A	N/A
2	Under saddle	1	N/A	N/A	N/A	N/A	N/A
3	Washer	1	CATS100108	CATS150108	CATS200108	CATS200108	CATS300108
4	Screw-LHCS	1	CBE821028-1D	CBE1221028-1D	CBE1223028-1D	CBE1223028-1D	CBE1229028-1D
5	Screw-SET	1	CCA1219028-5A	CCA1219028-5A	CCA1219028-5A	CCA1219028-5A	CCA1223028-5A

Repair Parts List - Figure 4-2							
Item	Description	Qty.	Part number				
			CATS400	CATS500	CATS600	CATS800	CATS1000
1	Upper saddle	1	N/A	N/A	N/A	N/A	N/A
2	Under saddle	1	N/A	N/A	N/A	N/A	N/A
3	Washer	1	CATS400108	CATS500108	CATS600108	CATS800108	CATS1000108
4	Screw-LHCS	1	CBA1233028-1D	CBE1233028-1D	CBE1233028-1D	CBE1233028-1D	CBE1641028-1D
5	Screw-SET	1	CCA1625028-5A	CCA1625028-5A	CCA1625028-5A	CCA1625028-5A	CCA1625028-5A

Repair Parts List - Figure 5-1				
Item	Description	Qty.	Part number	
			CATS20	CATS30
1	Upper saddle	1	N/A	N/A
2	Under saddle	1	N/A	N/A
3	Washer	1	CATS20108	CATS30108
4	Screw-LHCS	1	CBE625028-1D	CBE625028-1D

Repair Parts List - Figure 5-2					
Item	Description	Qty.	Part number		
			CATS13	CATS53	CATS103
1	Spring		BSS2634D	BSS2018D	BSS2635D
2	Upper saddle	1	N/A	N/A	N/A
3	Spring guide	1	CATS12108	CATS53108	CATS103108
4	Under saddle	1	N/A	N/A	N/A
5	Screw-SHCS	2	CBE415028-1A	CBE515028-1A	CBE817028-1A
6	Screw-SHCS	1	CBE419028-1A	CCA1625028-5A	CBE821028-1A

Repair Parts List - Figure 5-3				
Item	Description	Qty.	Part number	
			CATS12	CATS52
1	O-Ring		B1208503	B1021503
2	Spring		BSS2634D	BSS2018D
3	Upper saddle	1	N/A	N/A
4	Under saddle	1	N/A	N/A
5	Spring guide	1	CATS12108	CATS53108
6	Screw-SHCS	1	CBE419028-1A	CBE621028-1A

NOTES

