



Repair Parts Sheet

**BHP Puller Sets
and Attachments**

Note: See pages 6 through 12 for repair parts lists and diagrams.

Hinweis: Siehe Seiten 6 bis 12 für Ersatzteillisten und Schemata.

Nota: Véanse las páginas 6-12 para las listas de piezas de recambio y diagramas.

Remarque : Voir les pages 6 -12 pour les listes des pièces de rechange et les schémas.

Nota: Per consultare i diagrammi e gli elenchi dei pezzi di ricambio, fare riferimento alle pagine 6 - 12.

N.B.: Zie pagina's 6 tot en met 12 voor reparatielijsten en schema's.

Замечание: См. стр. 6-12 для запасных частей и схем.

illustration 5 - How to set up a Grip Puller. Numbers correspond with table A on page 7.

figure 5 - Comment assembler un extracteur à griffes. Les números correspondent à ceux de la table A page 7.

Abbildung 5 - Montieren der Abzugsätze.

Die Zahlen stimmen mit Tabelle A auf Seite 7 überein.

figura 5 - Come montare un estrattore a griffe. I numeri corrispondono con quelli della tabella A a pagina 7.

ilustración 5 - Modo de colocación de un extractor de garras. Los números corresponden con el cuadro A en la página 7.

illustratie 5 - Opbouwen van Trekkersets met trekarmen. De nummers komen overeen met tabel A op bladzijde 7.

Рис. 5. Сборка зажимного съёмника. Числа на рисунке соответствуют числам в таблице А (стр. 7).

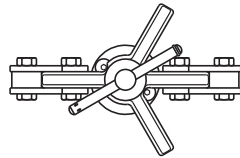

2 grip arms
Tête à 2 griffes
Kreuzkopf 2-armig
Traversa 2 griffe
Cruceta doble
2-armig juk
Зажим с 2 лапами

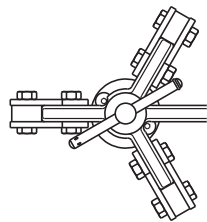

3 grip arms
Tête à 3 griffes
Kreuzkopf 3-armig
Traversa 3 griffe
Cruceta triple
3-armig juk
Зажим с 3 лапами

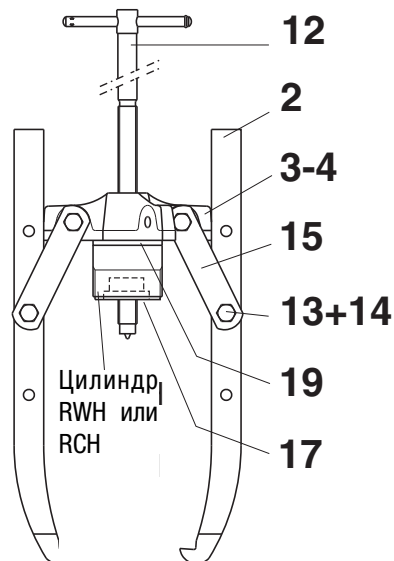

**Note: Refer to
Illustration 5
(page 6)**

TABLE A - INDIVIDUAL COMPONENTS OF GRIP PULLER SETS

Model Number - Grip Puller Sets		BHP-152	BHP-251G	BHP-351G	BHP-551G
Maximum Capacity		8 ton	20 ton	30 ton	50 ton
Hydraulic Components	Pump	P-142	P-392	P-392	P-80
	Cylinder	RWH-121	RCH-202	RCH-302	RCH-603
	Gauge	GF-120P (US) GF-120B (Eur) + GA-4 ¹⁾	GF-813P (US) GF-813B (Eur) + GA-3 ¹⁾	GF-813P (US) GF-813B (Eur) + GA-3 ¹⁾	GF-813P (US) GF-813B (Eur) + GA-3 ¹⁾
	Hose	HB-7206QB	HC-7206	HC-7206	HC-7206
Weight / Poids		22 kg 48 lbs	56 kg 123 lbs	91 kg 200 lbs	160 kg 353 lbs
1	Cyl. Adapter	--	--	--	--
2	Grip Arms	HP-1125 (3x)	HP-2125 (3x)	HP-3125 (3x)	HP-5125 (3x)
3	Double Crosshead	--	HP-2120	HP-3120	HP-5120
4	Triple Crosshead	HP-1130	HP-2130	HP-3130	HP-5130
12	Adjusting Rod	HP-1111	HP-2111	HP-3111	HP-5111
13	Strap Nut Kit (Includes 6 nuts)	HP-1123	HP-2023	HP-3123	HP-5023
14	Strap Screw Kit (includes 6 screws)	HP-1122	HP-2122	HP-3122	HP-5122
15	Straps	HP-1121 (6x)	HP-2121 (6x)	HP-3121 (6x)	HP-5121 (6x)
17	Threaded Saddle	--	HP-2015	HP-3015	HP-5016
19	Mounting Screw Kit (includes 2 screws)	HP-1120	HP-2213	HP-2013	HP-5013

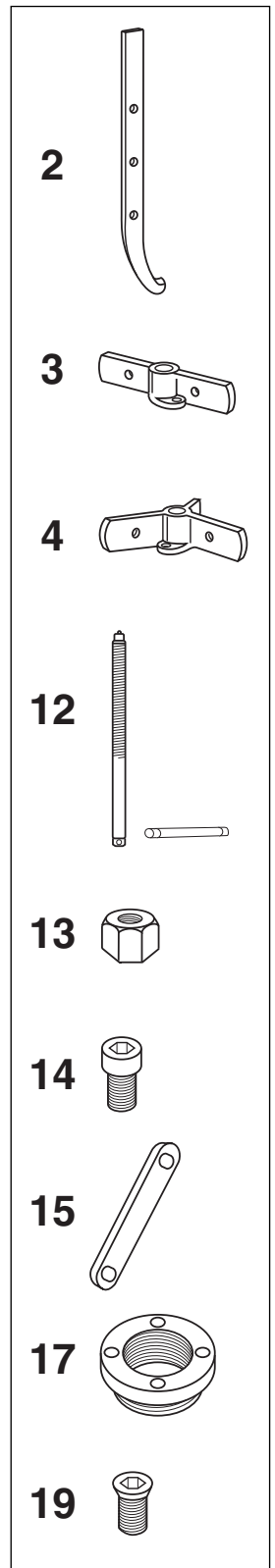

1) GA = Gauge Adaptor

illustration 6 - How to set up a Cross Bearing Puller. Numbers correspond with table B on page 9

figure 6 - Comment assembler un extracteur à tirants. Les números correspondent à ceux de la table B page 9.

Abbildung 6 - Montieren der Jochabzieher. Die Zahlen stimmen mit Tabelle B auf Seite 9 überein.

figura 6 - Come montare un estrattore a tiranti. I numeri corrispondono con quelli della tabella B a pagina 9.

ilustración 6 - Modo de colocación de un extractor de cojinetes. Los números corresponden con el cuadro B en la página 9.

illustratie 6 - Opbouwen van brugstuk-lagertrekkers. De nummers komen overeen met tabel B op bladzijde 9.

Рис. 6. Сборка съемника-хомута. Числа на рисунке соответствуют числам в таблице В (стр. 9).

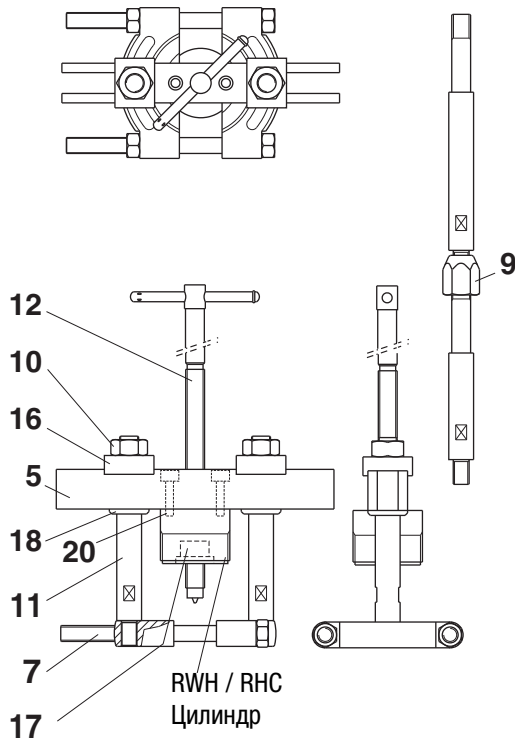

illustration 7 - How to set up a Internal Puller. Numbers correspond with table B on page 9

figure 7 - Comment assembler un extracteur intérieur. Les números correspondent à ceux de la table B page 9.

Abbildung 7 - Montieren der Lagerschalenabzieher. Die Zahlen stimmen mit Tabelle B auf Seite 9 überein.

figura 7 - Come montare un estrattore per interni. I numeri corrispondono con quelli della tabella B a pagina 9.

ilustración 7 - Modo de colocación de un extractor interior. Los números corresponden con el cuadro B en la página 9.

illustratie 7 - Opbouwen van inwendige lagertrekkers. De nummers komen overeen met tabel B op bladzijde 9.

Рис. 7. Сборка съемника с внутренним захватом. Числа на рисунке соответствуют числам в таблице В (стр. 9).

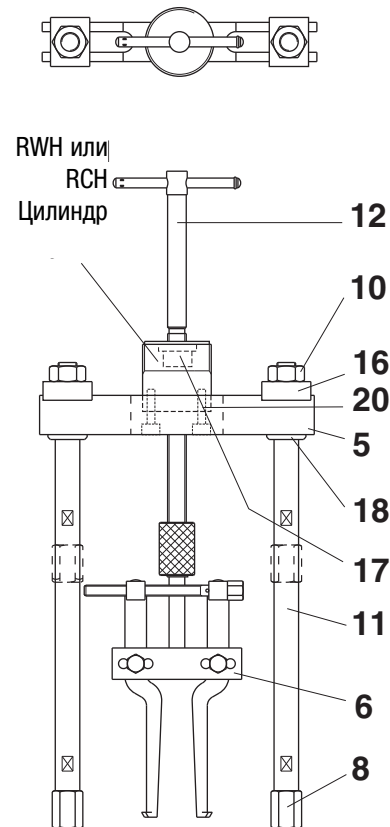

**Note: Refer to
Illustration 6 or 7
(page 8)**

TABLE B - INDIVIDUAL COMPONENTS OF CROSS-BEARING PULLER SETS

Cross-Bearing Puller Sets		BHP-162	BHP-261G	BHP-361G	BHP-561G
Max. Capacity		8 ton	20 ton	30 ton	50 ton
Hydraulic Components	Pump	P-142	P-392	P-392	P-80
	Cylinder	RWH-121	RCH-202	RCH-302	RCH-603
	Gauge	GF-120P (US) GF-120B (Eur) + GA-4 ¹⁾	GF-813P (US) GF-813B (Eur) + GA-3 ¹⁾	GF-813P (US) GF-813B (Eur) + GA-3 ¹⁾	GF-813P (US) GF-813 (Eur) + GA-3 ¹⁾
	Hose	HB-7206QB	HC-7206	HC-7206	HC-7206
Weight		26 kg 57 lbs	62 kg 164 lbs	121 kg 267 lbs	185 kg 408 lbs
5	Slotted Crosshead	HP-1103	HP-2103	HP-3104	HP-5103
6	Bearing Cup Pull.	BHP-180	BHP-280	BHP-380	BHP-580
7	Bearing Puller	BHP-181	BHP-282	BHP-382	BHP-582
8	Leg End Kit (includes 2 leg ends)	HP-2009	HP-2009	HP-3039	--
9	Leg Reducer Kit (includes 4 reducers)	HP-2031	HP-2031	HP-3041	--
10	Leg Nut Kit (includes 2 nuts)	HP-2001	HP-2001	HP-3031	HP-5001
11	Leg ²⁾	HP-1136 (2x) HP-1137 (2x)	HP-2006 (2x) HP-2007 (2x) HP-2008 (2x) HP-2012 (2x)	HP-3036 (2x) HP-3037 (2x) HP-3038 (2x)	HP-5007 (2x) HP-5008 (2x)
12	Adjusting Rod	HP-1111	HP-2111	HP-3111	HP-5111
16	Slide Plate	HP-1105 (2x)	HP-2105 (2x)	HP-3135 (2x)	HP-5102 (2x)
17	Threaded Saddle	--	HP-2015	HP-3015	HP-5016
18	Washer Kit (includes 2 washers)	HP-1102	HP-2002	HP-3032	HP-5132
20	Mounting Screw Kit (includes 2 screws)	HP-1213	HP-2113	HP-3113	HP-5113

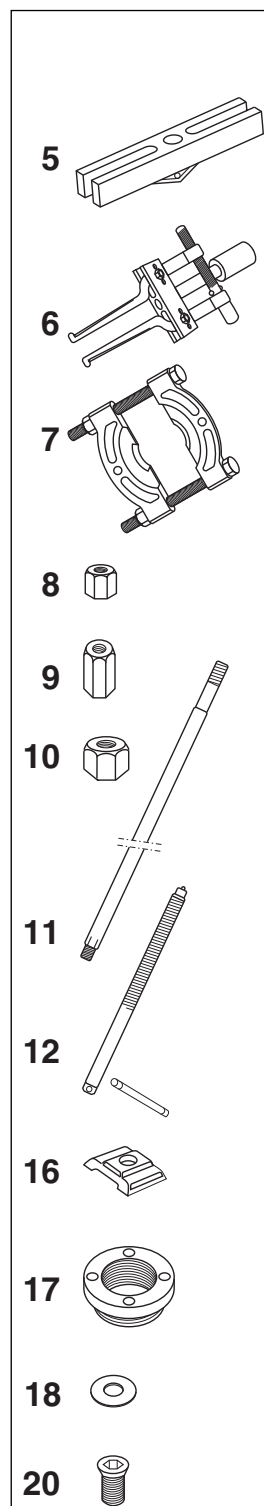

1) GA = Gauge Adaptor 2) See Leg Lengths table on page 11 for additional information.

Note: Refer to
Illustration 5 (page 6) or
illustrations 6 & 7 (page 8)

TABLE C - INDIVIDUAL COMPONENTS OF MULTI-PURPOSE PULLER SETS

Multi-Purpose Puller Sets		BHP-1752	BHP-2751G	BHP-3751G	BHP-5751G
Capacity		8 ton	20 ton	30 ton	50 ton
Hydraulic Components	Pump	P-142	P-392	P-392	P-80
	Cylinder	RWH-121	RCH-202	RCH-302	RCH-603
	Gauge	GF-120P (US) GF-120B (Eur) + GA-4 1)	GF-813P (US) GF-813B (Eur) + GA-3 1)	GF-813P (US) GF-813B (Eur) + GA-3 1)	GF-813P (US) GF-813B (Eur) + GA-3 1)
	Hose	HB-7206QB	HC-7206	HC-7206	HC-7206
2 Grip Arms		HP-1125 (3x)	HP-2125 (3x)	HP-3125 (3x)	HP-5125 (3x)
3 Double Crosshead		--	HP-2120	HP-3120	HP-5120
4 Triple Crosshead		HP-1130	HP-2130	HP-3130	HP-5130
5 Slotted Crosshead		HP-1103	HP-2103	HP-3104	HP-5103
6 Bearing Cup Pull.		BHP-180	BHP-280	BHP-380	BHP-580
7 Bearing Puller		BHP-181	BHP-282	BHP-382	BHP-582
8 Leg End Kit (includes 2 leg ends)		HP-2009	HP-2009	HP-3039	--
9 Leg Reducer Kit (includes 4 reducers)		HP-2031	HP-2031	HP-3041	--
10 Leg Nut Kit (includes 2 nuts)		HP-2001	HP-2001	HP-3031	HP-5001
11 Leg 2)		HP-1136 (2x) HP-1137 (2x)	HP-2006 (2x) HP-2007 (2x) HP-2008 (2x) HP-2012 (2x)	HP-3036 (2x) HP-3037 (2x) HP-3038 (2x)	HP-5007 (2x) HP-5008 (2x)
12 Adjusting Rod		HP-1111	HP-2111	HP-3111	HP-5111
13 Strap Nut Kit (includes 6 nuts)		HP-1123	HP-2023	HP-3123	HP-5023
14 Strap Screw Kit (includes 6 screws)		HP-1122	HP-2122	HP-3122	HP-5122
15 Straps		HP-1121 (6x)	HP-2121 (6x)	HP-3121 (6x)	HP-5121 (6x)
16 Slide Plate		HP-1105 (2x)	HP-2105 (2x)	HP-3135 (2x)	HP-5102 (2x)
17 Threaded Saddle		--	HP-2015	HP-3015	HP-5016
18 Washer Kit (includes 2 washers)		HP-1102	HP-2002	HP-3032	--
19 Short Mounting Screw Kit (includes 2 screws)		HP-1120	HP-2113	HP-2013	HP-5013
20 Long Mounting Screw Kit (includes 2 screws)		HP-1213	HP-2213	HP-3113	HP-5113

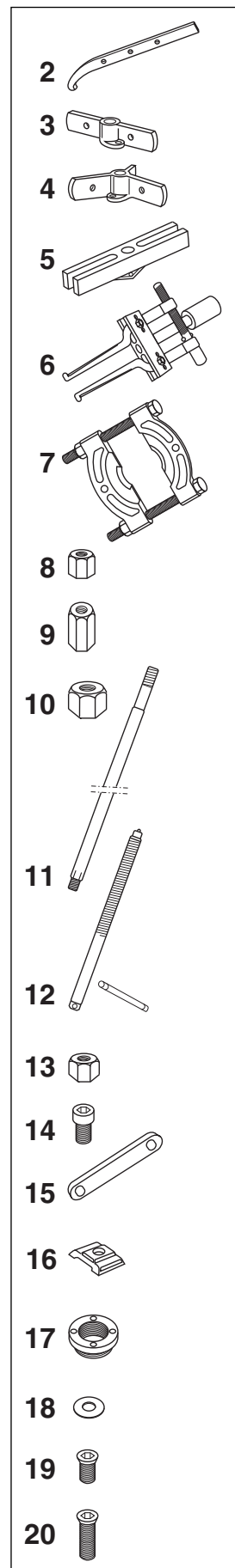

1) GA = Gauge Adaptor 2) See Leg Lengths table on page 11 for additional information.

**Note: Refer to
Illustration 5
(page 6)**

TABLE D - INDIVIDUAL COMPONENTS OF GRIP PULLER ATTACHMENTS

Grip Puller Attachments	BHP-1762	BHP-252	BHP-352	BHP-552
Capacity	8 ton	20 ton	30 ton	50 ton
2 Grip Arms	HP-1125 (3x)	HP-2125 (3x)	HP-3125 (3x)	HP-5125 (3x)
3 Double Crosshead	--	HP-2120	HP-3120	HP-5120
4 Triple Crosshead	HP-1130	HP-2130	HP-3130	HP-5130
12 Adjusting Rod	HP-1111	HP-2111	HP-3111	HP-5111
13 Strap Nut Kit (includes 6 nuts)	HP-1123	HP-2023	HP-3123	HP-5023
14 Strap Screw Kit (includes 6 screws)	HP-1122	HP-2122	HP-3122	HP-5122
15 Straps	HP-1121 (6x)	HP-2121 (6x)	HP-3121 (6x)	HP-5121 (6x)
17 Threaded Saddle	--	HP-2015	HP-3015	HP-5016
19 Mounting Screw Kit (includes 2 screws)	HP-1120	HP-2213	HP-2013	HP-5013

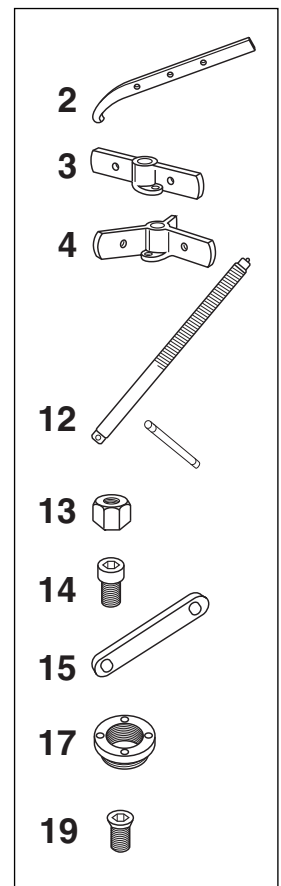

LEG LENGTHS (See item #11, tables B, C and E)

Leg Part Number	Leg Length inch [mm]	Used on Puller Models:
HP-1136	4.2 [106]	BHP162, BHP-1752, BHP-1772
HP-1137	14.1 [357]	
HP-2006	9.4 [240]	BHP-261G, BHP-2751G, BHP-262
HP-2007	16.5 [420]	
HP-2008	22.4 [570]	
HP-2012	4.5 [115]	
HP-3036	8.0 [204]	BHP-361G, BHP-3751G, BHP-362
HP-3037	18.1 [18.1]	
HP-3038	28.0 [710]	
HP-5007	24.0 [608.5]	BHP-561G, BHP-5751G, BHP-362
HP-5008	34.0 [863.5]	

Refer to Illustration
6 or 7 (page 8)

TABLE E - INDIVIDUAL COMPONENTS OF PULLER SETS ATTACHMENTS

Puller Set Attachments	BHP-1772	BHP-262	BHP-362	BHP-562
Capacity	8 ton	20 ton	30 ton	50 ton
5 Slotted Crosshead	HP-1103	HP-2103	HP-3104	HP-5103
6 Bearing Cup Pull.	BHP-180	BHP-280	BHP-380	BHP-580
7 Bearing Puller.	BHP-181	BHP-282	BHP-382	BHP-582
8 Leg End Kit (includes 2 leg ends)	HP-2009	HP-2009	HP-3039	--
9 Leg Reducer Kit (includes 4 leg ends)	HP-2031	HP-2031	HP-3041	--
10 Leg Nut Kit (includes 2 nuts)	HP-2001	HP-2001	HP-3031	HP-5001
11 Leg 1)	HP-1136 (2x) HP-1137 (2x)	HP-2006 (2x) HP-2007 (2x) HP-2008 (2x) HP-2012 (2x)	HP-3036 (2x) HP-3037 (2x) HP-3038 (2x)	HP-5007 (2x) HP-5008 (2x)
12 Adjusting Rod	HP-1111	HP-2111	HP-3111	HP-5111
16 Slide Plate	HP-1105 (2x)	HP-2105 (2x)	HP-3135 (2x)	HP-5102 (2x)
17 Threaded Saddle	--	HP-2015	HP-3015	HP-5016
18 Washer Kit (includes 2 washers)	HP-1102	HP-2002	HP-3032	--
20 Mounting Screw Kit (includes 2 screws)	HP-1213	HP-2113	HP-3113	HP-5113

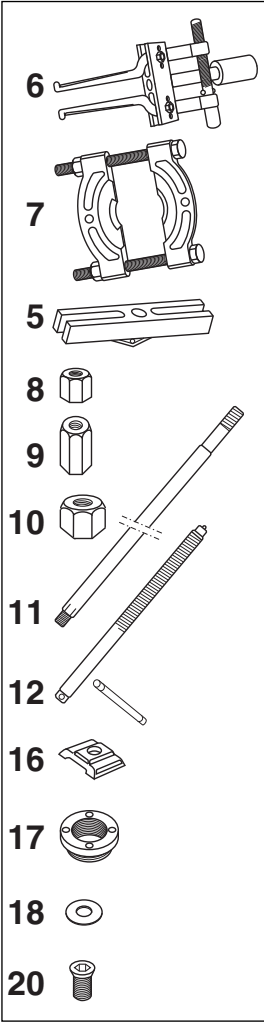

1) See Leg Lengths table on page 11 for additional information.

TABLE F - INDIVIDUAL COMPONENTS OF BEARING PULLER

Bearing Puller	BHP-181	BHP-282	BHP-382	BHP-582
Capacity	8 ton	20 ton	30 ton	50 ton
Rod	BHP181K	BHP282K	BHP582K	
Rod Nut				

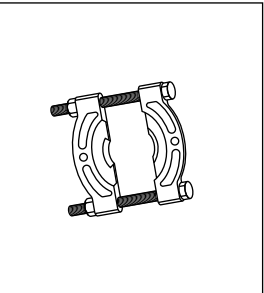

To Protect Your Warranty, Use Only ENERPAC Hydraulic Oil.

Enerpac recommends that all kit components be installed to insure optimum performance of the repaired product.



WARNING: STOP RINGS ON RWH CYLINDER MODELS ARE SPRING LOADED

IF NOT CONTAINED DURING DISASSEMBLY, SPRING AND STOP RING COULD CAUSE PERSONAL INJURY.

NOTE: Cylinder Base, item 1, is not available as a service item. Order complete cylinder.

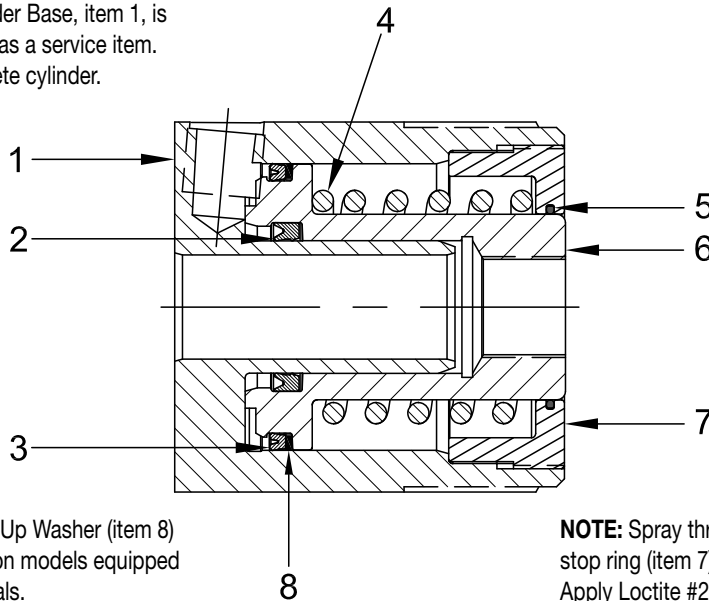

NOTE: Back-Up Washer (item 8) is only used on models equipped with Viton seals.

NOTE: Spray threads on base (item 1) and stop ring (item 7) with Loctite Activator #7471. Apply Loctite #222 to threads after Activator has dried. Assemble and torque stop ring (item 7) to 50-100 In-Lbs (5-11 Nm).

Parts List - Models RWH-121 and RWH-121V

Item	Model Number		Qty.	Description
	RWH-121	RWH-121V		
1	CH970030	CH970030	1	Base (not available as a service item)
2	DW1253041	(not used)	1	★ U-Cup, Standard
	(not used)	CF476041	1	❖ U-Cup, Viton
3	CJ422041	(not used)	1	★ U-Cup, Standard
	(not used)	CA520041	1	❖ U-Cup, Viton
4	Y397110	Y397110	1	Spring
5	B1028803	(not used)	1	★ O-Ring, Standard
	(not used)	B1028203	1	❖ O-Ring, Viton
6	CH971040	CH971040	1	Plunger
7	B47035	B47035	1	Stop Ring
8	(not used)	B1225564	1	❖ Back-Up Washer, Viton

★ Items included in and available only as part of Standard Repair Kit RWH121K1.

❖ Items included in and available only as part of Viton Repair Kit QMH120VK.

Enerpac Worldwide Locations

◆ e-mail: info@enerpac.com

◆ internet: www.enerpac.com

Africa

ENERPAC Middle East FZE
Office 423, JAFZA 15
P.O. Box 18004
Jebel Ali, Dubai
United Arab Emirates
Tel: +971 (0)4 8872686
Fax: +971 (0)4 8872687

Australia, New Zealand Actuant Australia Ltd.

Block V Unit 3
Regents Park Estate
391 Park Road
Regents Park NSW 2143
(P.O. Box 261) Australia
Tel: +61 297 438 988
Fax: +61 297 438 648

Brazil

Power Packer do Brasil Ltda.
Rua dos Inocentes, 587
04764-050 - Sao Paulo (SP)
Tel: +55 11 5687 2211
Fax: +55 11 5686 5583
Toll Free in Brazil:
Tel: 0800 891 5770
vendasbrasil@enerpac.com

Canada

Actuant Canada Corporation
6615 Ordan Drive, Unit 14-15
Mississauga, Ontario L5T 1X2
Tel: +1 905 564 5749
Fax: +1 905 564 0305
Toll Free:
Tel: +1 800 268 4987
Fax: +1 800 461 2456
Technical Inquiries:
techservices@enerpac.com

China

Actuant Industries Co. Ltd.
No. 6 Nanjing Road
Taicang Economic Dep Zone
Jiangsu, China
Tel: +86 0512 5328 7529
+86 0512 5328 7500 7529
Fax: +86 0512 5335 9690

Actuant China Ltd. (Peking)

709B Diyang Building
Xin No. 2
Dong San Huan North Rd.
Beijing City
100028 China
Tel: +86 10 845 36166
Fax: +86 10 845 36220

France, Switzerland francophone

ACTUANT - ENERPAC
France S.A., ZA de Courtaboeuf
32, avenue de la Baltique
91140 Villebon / Yvette
France
Tel: +33 1 60 13 68 68
Fax: +33 1 69 20 37 50

Germany, Austria, Switzerland, Greece, Baltic States, Central and Eastern Europe

ENERPAC GmbH
P.O. Box 300113
D-40401 Düsseldorf
Willstätterstrasse 13
D-40549 Düsseldorf
Germany
Tel: +49 211 471 490
Fax: +49 211 471 49 28

India

ENERPAC Hydraulics
(India) Pvt. Ltd.
No. 1A,
Peenya Industrial Area,
IInd Phase
Bangalore, 560 058 India
Tel: +91 80 40 792 777
Fax: +91 80 40 792 792

Italy

ENERPAC S.p.A.
Via Canova 4
20094 Corsico (Milano)
Tel: +39 02 4861 111
Fax: +39 02 4860 1288

Japan

Applied Power Japan LTD KK
Besshochou 85-7
Kita-ku,
Saitama-shi 331-0821
Japan
Tel: +81 48 662 4911
Fax: +81 48 662 4955

Middle East, Turkey and Caspian Sea

ENERPAC Middle East FZE
Office 423, JAFZA 15
P.O. Box 18004
Jebel Ali, Dubai
United Arab Emirates
Tel: +971 (0)4 8872686
Fax: +971 (0)4 8872687

Russia and CIS (excl. Caspian Sea Countries)

Actuant LLC
Admiral Makarov Street 8
125212 Moscow, Russia
Tel: +7-495-9809091
Fax: +7-495-9809092

Sweden, Denmark, Norway, Finland and Iceland

ENERPAC Scandinavia AB
Fabriksgatan 7
412 50 Gothenburg
Sweden
Tel: +46 31 7990281
Fax: +46 31 7990010
scandinavianinquiries@enerpac.com

Singapore

Actuant Asia Pte. Ltd.
37C, Benoi Road Pioneer Lot,
Singapore 627796
Tel: +65 68 63 0611
Fax: +65 64 84 5669
Toll Free: +1800 363 7722
Technical Inquiries:
tech.service-sg@enerpac.com

South Korea

Actuant Korea Ltd.
3Ba 717,
Shihwa Industrial Complex
Jungwang-Dong, Shihung-Shi,
Kyunggi-Do
Republic of Korea 429-450
Tel: +82 31 434 4506
Fax: +82 31 434 4507

Spain and Portugal

ENERPAC SPAIN, S.L.
Avda. Los Frailes, 40 - Nave C
& D
Pol. Ind. Los Frailes
28814 DAGANZO DE ARRIBA
(Madrid)
Spain
Tel: +34 91 884 86 06
Fax: +34 91 884 86 11

Sweden, Denmark, Norway, Finland and Iceland

Enerpac Scandinavia AB
Fabriksgatan 7
412 50 Gothenburg
Sweden
Tel: +46 (0) 31 7990281
Fax: +46 (0) 31 7990010
Inquiries:
Scandinavianinquiries@enerpac.com

The Netherlands, Belgium, Luxembourg

ENERPAC B.V.
Galvanistraat 115, 6716 AE Ede
P.O. Box 8097, 6710 AB Ede
The Netherlands
Tel: +31 318 535 800
Fax: +31 318 525 613
+31 318 535 848
beneluxinquiries@enerpac.com
Technical Inquiries Europe:
techsupport.europe@enerpac.com

United Kingdom, Ireland

Enerpac Ltd
Bentley Road South
Darlaston, West Midlands
WS10 8LQ, United Kingdom
Tel: +44 (0)121 50 50 787
Fax: +44 (0)121 50 50 799

USA, Latin America and Caribbean

ENERPAC
P.O. Box 3241
6100 N. Baker Road
Milwaukee, WI 53209 USA
Tel: +1 262 781 6600
Fax: +1 262 783 9562

User inquiries:

+1 800 433 2766

Inquiries/orders:

+1 800 558 0530

Technical Inquiries:

techservices@enerpac.com

ENERPAC

704 W. Simonds
Dallas, TX 75159 USA
Tel: +1 972 287 2390
Fax: +1 972 287 4469

09/30/09

All Enerpac products are guaranteed against defects in workmanship and materials for as long as you own them. For your nearest authorized Enerpac Service Center, visit us at www.enerpac.com

⚠ WARNING
Stop rings on RCH and RWH models are spring loaded!
If not contained during disassembly, spring and stop ring could cause personal injury.

(S) Stop ring threads are staked. Stake mark must be removed prior to attempting to remove stop ring. Restake after testing repaired cylinder.

Use Loctite 545
or teflon tape.

Torque to 50-60 ft-lb.
[67,6-81,1 Nm]

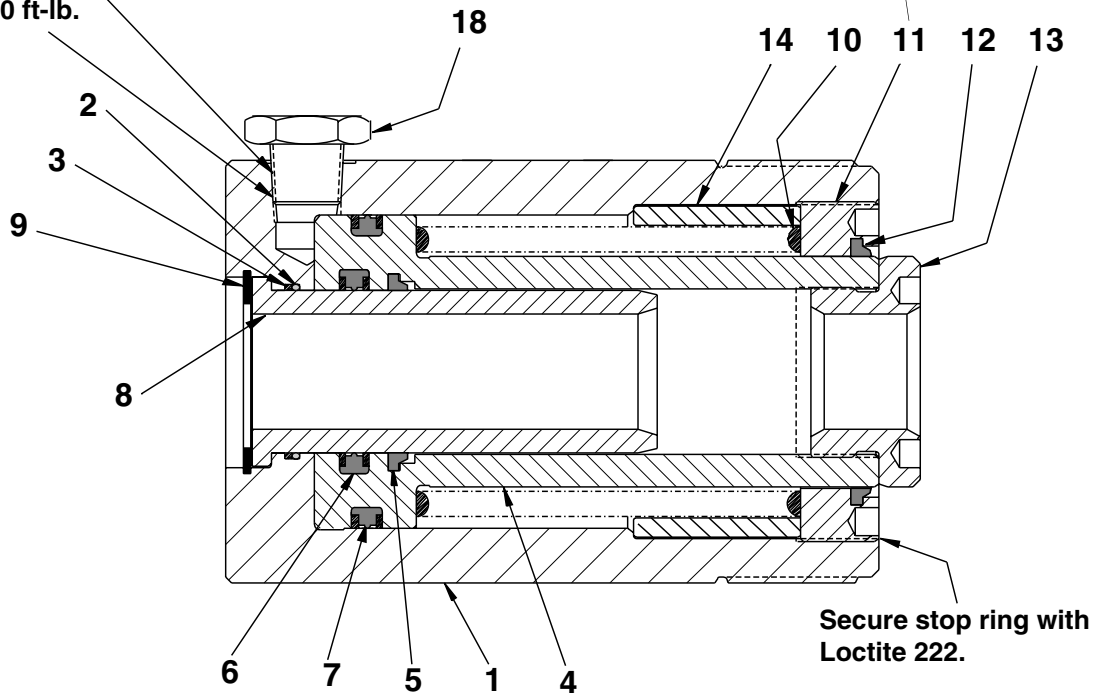

Secure stop ring with
Loctite 222.

NOTE: Cylinder Base, Item #1 is
not available as a service item.
Order Complete Cylinder.

INSTALL ALL KIT COMPONENTS TO INSURE OPTIMUM PERFORMANCE OF THE REPAIRED CYLINDER.

REPAIR PARTS LIST

Item No.	RCH-202	RWH-200 RWH-200V	RWH-202 RWH-202V	Quantity	Description
1				1	Cylinder Assembly
2	★	★	★	1	O-Ring
3	★	★	★	1	Back-up Ring
4	DA5164040	DA5163040	DA5164040	1	Plunger
5	★	★	★	1	Wiper Ring
6	★	★	★	1	G-T Ring
7	★	★	★	1	G-T Ring Viton
8	DA5160268	DA5159268	DA5160268	1	Center Tube
9	★	★	★	1	Retaining Ring
10	CF707110	CF707110	CF707110	1	Spring
11	CJ671044	CJ671044	CJ671044	1	Stop Ring
12	★	★	★	1	Wiper Ring Viton
13	CB894045	CB894045	CB894045	1	Saddle
14	CJ672044	CJ672044	CJ672044	1	Stop Ring
15	CR-400	—	—	1	Half Coupler (not shown)
18	—	FZ1630	FZ1630	1	Reducer Bushing

★ Indicates item included in and available only as part of Repair Kit RCH-202K.
For viton cylinders, order Repair Kit RCH-202KV1.

Australia
ENERPAC, Applied Power Australia Ltd.
Block V Unit 3,
Regents Park Estate,
391 Park Road
Regents Park NSW 2143
(P.O. Box 261) Australia
Tel: +61 297 438 988
Fax: +61 297 438 648

Brazil
Power Packer do
Brasil LTDA
Avenida Ferraz
Alvim nº 1012
(09961-550) - Diadema
São Paulo, Brazil
Tel: +55 11 4051 1188
Fax: +55 11 4051 3699

China
Shanghai Blackhawk
Machinery Co Ltd
15H Jinxuan Building
238 Nandan Road (E)
Shanghai, 200030, China
Tel: +86 21 6469 8732
Fax: +86 21 6469 8721

France, Greece, Turkey, Middle East,
Africa
ENERPAC S.A.
B.P. 200, Parc d'Activités
du Moulin de Massy
F-91882 Massy CEDEX (Paris) France
Tel: +33 01 601 368 68
Fax: +33 01 692 037 50

Germany, Denmark, Scandinavia,
Austria, Switzerland, Eastern
Europe, CIS
ENERPAC
Applied Power GmbH
P.O. Box 300113
D-40401 Düsseldorf, Germany
Tel: +49 211 471 490
Fax: +49 211 471 49 28/40

Holland, Belgium, Luxembourg,
ENERPAC B.V.
Storkstraat 25
P.O. Box 269
3900 AG Veenendaal, Holland
Tel: +31 318 535 911
Fax: +31 318 535 848
+31 318 526 645

Hong Kong
ENERPAC
Room 907 Workingberg
Commercial Building
41-47 Marble Road,
North Point
Tel: +852-2561 6295
Fax: +852-2561 6772

India
ENERPAC
Hydraulic (India) Pvt Ltd
Plot No. A-571
MIDC, TTC Industrial Area
Mahape-400 701,
Navi Mumbai, India
Tel: +91 22 769 47 78
Fax: +91 22 769 84 73

Italy
ENERPAC Applied Power Italiana S.p.A.
Via Canova 4,
20094 Corsico (Milano)
Tel: +39 2 486 111 00
Fax: +39 2 486 012 88

Japan
Applied Power Japan Ltd.
10-17 Sasame Kita-Machi
Toda-Shi, Saitama #335, Japan
Tel: +81 048 421 2311
Fax: +81 048 421 8949

Malaysia
Applied Power Hytec (M) Sdn Bhd 22-1,
Jalan SS 15/8B
Subang Jaya, 47500
P.J. Selangor
West Malaysia
Tel: (0203) 73729 23/39/19
Fax: (0203) 737 29 18

Mexico
ENERPAC Applied Power Mexico S.A. de
C.V.
Avenida Principal,
La Paz #100
Fracc. Industrial La Paz
42084 Pachuca, Hidalgo
Tel: +52 771 337 00
Fax: +52 771 838 00

Singapore
Applied Power Asia Pte Ltd
47 Jalan Pemimpin,
#01-02 & 01-03
Sin Cheong Bldg
Singapore 577200
Thomson Road,
P.O. Box 114
Singapore 915704
Tel: +65 258 16 77
Fax: +65 258 28 47

South Korea
ENERPAC
Applied Power Korea Ltd.
163-12 Dodang-Dong, Choong-Ku,
Buchun-shi, Kyunggi-Do
Republic of Korea
Tel: +82 32 675 08 36
Fax: +82 32 675 30 02

Spain, Portugal
ENERPAC Applied Power International S.A.
A. Valgrande 14
Nave 12
28108 Alcobendas (Madrid), Spain
Tel: +34 91 661 11 25
Fax: +34 91 661 47 89

United Kingdom, Ireland
ENERPAC Limited
Unit 3 Colemeadow Road
North Moons Moat, Redditch
Worcester B98 9PB
United Kingdom
Tel: +44 01527 598 900
Fax: +44 01527 585 500

USA, Canada, Latin America and
Caribbean
ENERPAC
6101 N. Baker Road
Milwaukee, WI 53209 USA
Tel: +1 414 781 66 00
Fax: +1 414 781 10 49

USA
User inquiries:
+1 800 433 2766
Distributor inquiries/orders:
+1 800 558 0530

Canada
User inquiries:
+1 800 426 4129
Distributor inquiries/orders:
+1 800 426 2284

Internet
www.enerpac.com

e-mail
info@enerpac.com

All Enerpac products are guaranteed against defects in workmanship and materials for as long as you own them.
Under this guarantee, free repair or replacement will be made to your satisfaction.

For your nearest authorized Enerpac Service Center, visit us at www.enerpac.com

Repair Parts Sheet	Revision	Revision Date	Product Code Beginning
L1627	Rev. J	11/2017	C



WARNING: STOP RINGS ON RCH MODELS ARE SPRING LOADED! IF NOT CONTAINED DURING DISASSEMBLY, SPRING AND STOP RING COULD CAUSE PERSONAL INJURY.

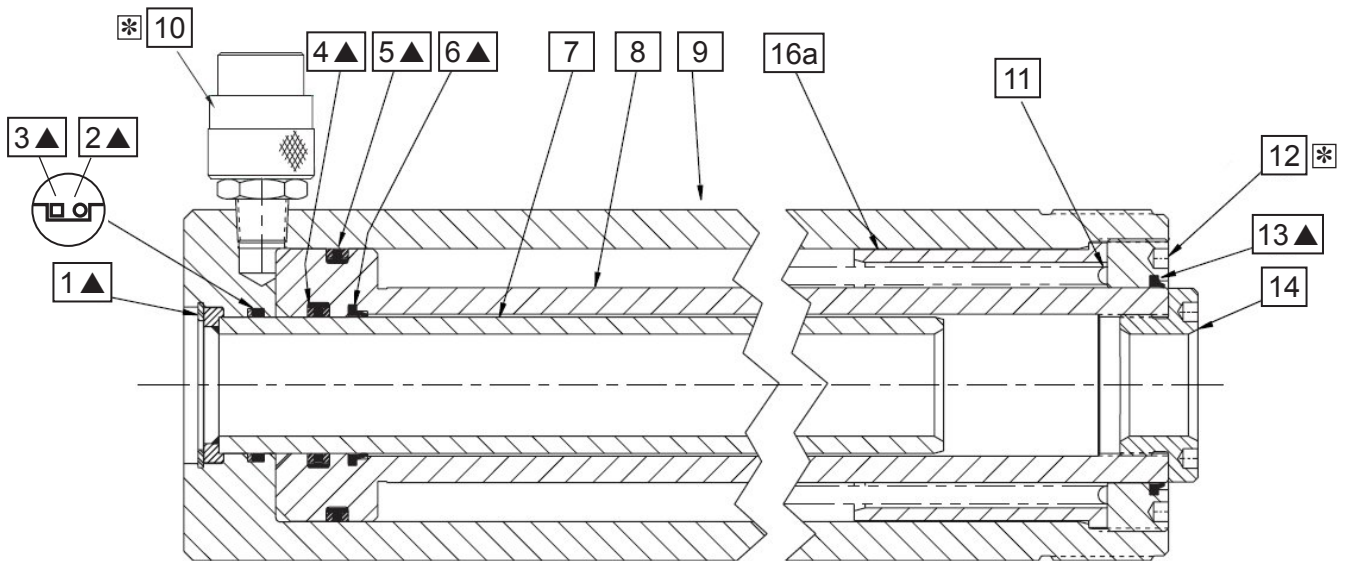

Models RCH302 and RCH306

▲ = Parts available in kits (see page 2).

* See  on page 2.

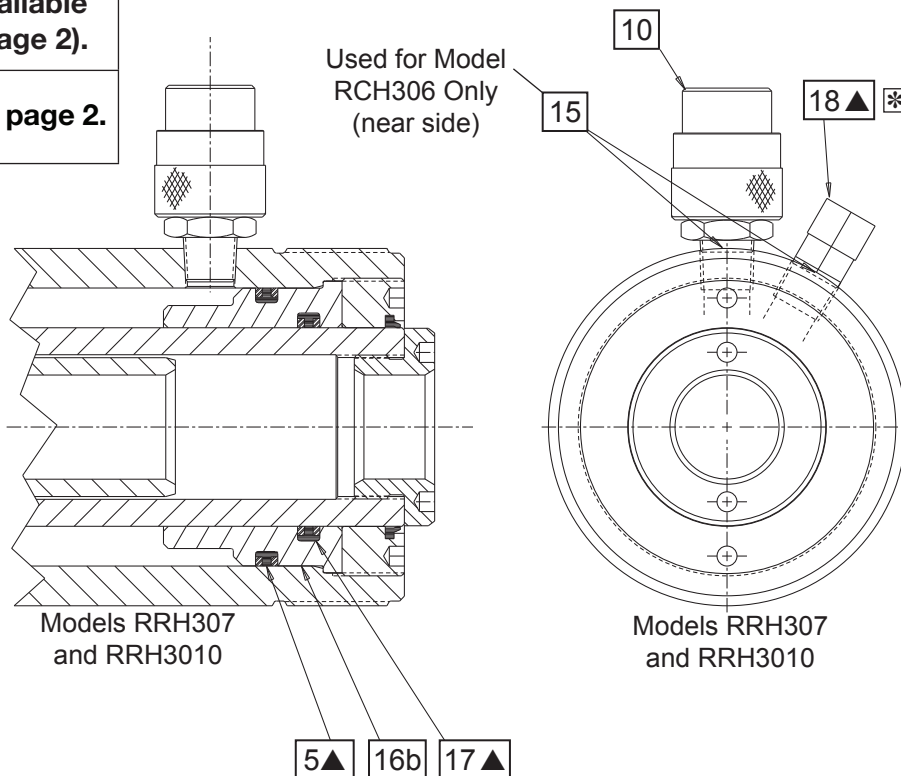

Models RRH307 and RRH3010

Models RRH307 and RRH3010

Repair Parts List						L1627
Item	Description	Qty.	RCH302	RCH306	RRH307	RRH3010
1	Retaining Ring ▲	1	A1006049	A1006049	A1006049	A1006049
2	O Ring ▲	1	B1090503	B1090503	B1090503	B1090503
3	Back Up Ring ▲	1	DA4984566	DA4984566	DA4984566	DA4984566
4	G T Ring ▲	1	B13271514	B13271514	B13271514	B13271514
	G T Ring ■	1	B13271516	B13271516	B13271516	B13271516
5	G T Ring ▲	1	B1338513	B1338513	B1338513 (Qty 2)	B1338513 (Qty 2)
	G T Ring ■	1	B1338515	B1338515	B1338515 (Qty 2)	B1338515 (Qty 2)
6	Wiper ▲	1	CJ142044	CJ142044	CJ142044	CJ142044
7	Center Tube	1	B1338515	B1338515	DA3468900	DA4101900
8	Plunger	1	DA4066040	DA3472040	DA3472040	DA4100040
9	Cylinder	1	Not available as service part. Order new cylinder.			
10	Coupler	1	CR400	CR400	---	---
	Coupler	2	---	---	CR400	CR400
11	Spring	1	CH259110	CR514110	---	---
12	Stopring	1	DA3464044	DA3464044	DA3464044	DA3464044
13	Wiper ▲	1	CJ50044	CJ50044	CJ50044	CJ50044
14	Saddle	1	CF698045	CF698045	CF698045	CF698045
15	Plug	1	---	A1009245	---	---
16a	Stop Tube	1	DA4069268	DA3466268	---	---
16b	Int. Stop Ring	1	---	---	DA3463044	DA3463044
17	G T Ring ▲	1	---	---	B1333514	B1333514
	G T Ring ■	1	---	---	B1333516	B1333516
18	Relief Valve ▲	1	---	---	CJ160900W	CJ160900W
19	Dust Cap (not shown) ▲	1	DD1782020	DD1782020	---	---
	Dust Cap (not shown) ▲	2	---	---	DD1782020	DD1782020
20	Thread Protector (not shown) ▲	1	CL402271	CL402271	CL402271	CL402271
21	Decal Warning (not shown) ▲	1	DA5625026	DA5625026	DA5625026	DA5625026
22	Decal Hollow (not shown) ▲	1	G668026	G668026	G668026	G668026
23	Decal, Warning (not shown) ▲	1	DA6027026	DA6027026	DC6154026	DC6154026
24	Coupler, O-Ring (not shown)	1	B1116803	B1116803	---	---
	Coupler, O-Ring (not shown)	2	---	---	B1116803	B1116803
	Repair Kit (standard seals)		RCH302K2	RCH302K2	RRH3010K2	RRH3010K2
	Repair Kit (Viton seals)		RWH302KV	RWH302KV	RWH302KV	RWH302KV

▲ = Indicates Items Included in Repair Kits RCH302K2 and RRH3010K2.

■ = Indicates Items Included in Repair Kits RWH302KV. Parts included in kits will vary, depending on kit ordered.

IMPORTANT: Shaded items are available only in kits (not sold separately).



Service Notes			L1627
Item	Model	Torque / Remark	
10	RCH / RRH	40 - 60 ft-lbs [54 - 81 Nm]	
10	RCH / RRH	Use Loctite 545 or Teflon tape	
12	RCH / RRH	Use Loctite 222	
18	RRH	40 - 60 ft-lbs [54 - 81 Nm]	
18	RRH	Set safety valve to 11,000 - 11,500 psi [760 - 795 bar]	
18	RRH	Use Loctite 545 or Teflon tape	



To maintain your warranty:

- Use only Enerpac Oil
- Have your products inspected and repaired by an Enerpac Authorized Service Center

ENERPAC

Visit www.enerpac.com for the location of the Enerpac Authorized Service Center nearest you.

To Protect Your Warranty, Use Only ENERPAC Hydraulic Oil.

Enerpac recommends that all kit components be installed to insure optimum performance of the repaired product.

WARNING! Stop rings on RCH models are spring loaded! If not contained during disassembly, spring and stop ring could cause personal injury.

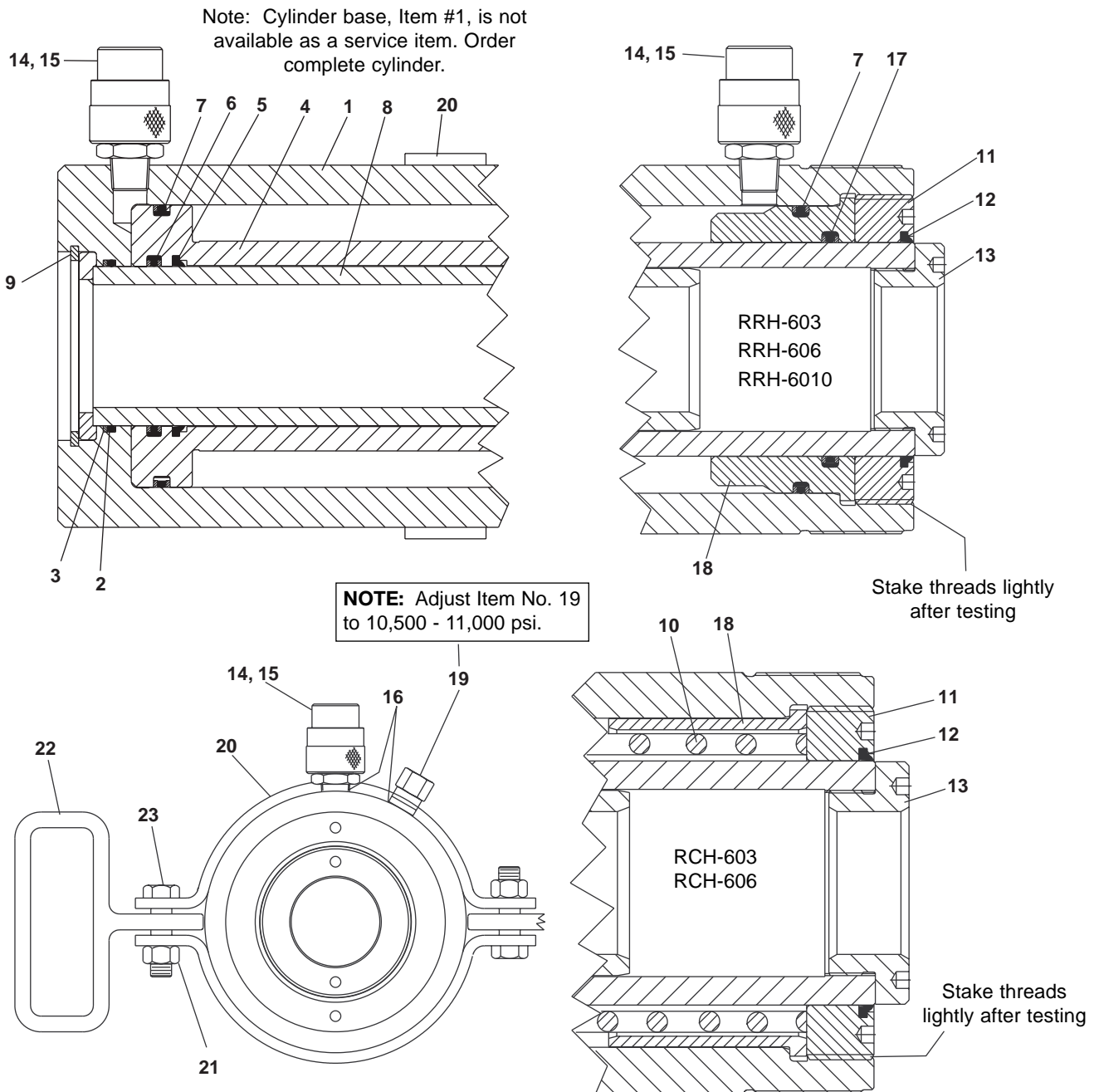

Figure 1

Item	RCH-603	RCH-606	RRH-603	RRH-606	RRH-6010	Qty.	Description
1		Order Complete	Cylinder			1	Cylinder
2	★	★	★	★	★	1	O-Ring
3	★	★	★	★	★	1	Back-Up Ring
4	DA4806040	DA4807040	DA4806040	DA4807040	DA4808040	1	Plunger
5	★	★	★	★	★	1	Wiper Ring
6	★	★	★	★	★	1	G-T Ring Assembly
7	★	★	★	★	★	2	G-T Ring Assembly (RCH Models use 1)
8	DA4809900	DA4810900	DA4809900	DA4810900	DA4811900	1	Center Tube
9	★	★	★	★	★	1	Retaining Ring
10	DA4816110	DA4816110	-----	-----	-----	1	Spring
11	CR106044	CR106044	CR106044	CR106044	CR106044	1	Stop Ring
12	★	★	★	★	★	1	Wiper Ring
13	CB891045	CB891045	CB891045	CB891045	CB891045	1	Saddle
14	CR400	CR400	CR400	CR400	CR400	2	Coupler (RCH Models use 1)
15	CD411	CD411	CD411	CD411	CD411	2	Dust Cap (Not Shown) (RCH Models use 1)
16	A1009245	A1009245	-----	-----	-----	2	Flush Plug (RCH Models Only)
17	-----	-----	★	★	★	1	G-T Ring Assembly
18	DA4814268	DA4814268	DA4813044	DA4813044	DA4813044	1	Inner Stop Ring
19	-----	-----	CJ160900W	CJ160900W	CJ160900W	1	Relief Valve Assembly
20	DA5238900SR	DA5238900SR	DA5238900SR	DA5238900SR	DA5238900SR	2	Collar (Incl.It.#21,22,23)
21	-----	-----	-----	-----	-----	2	Nut
22	-----	-----	-----	-----	-----	2	Handle
23	-----	-----	-----	-----	-----	2	Bolt
	RRH603K4	RRH603K4	RRH603K4	RRH603K4	RRH603K4	1	Repair Kit

★ Indicates Items Included in and Available Only in Repair Kits.

Enerpac Worldwide Locations

Africa

ENERPAC Middle East FZE
P.O. Box 18004
Jebel Ali, Dubai
United Arab Emirates
Tel: +971 (0)4 8872686
Fax: +971 (0)4 8872687

Australia

Actuant Australia Ltd.
Block V Unit 3
Regents Park Estate
391 Park Road
Regents Park NSW 2143
(P.O. Box 261) Australia
Tel: +61 297 438 988
Fax: +61 297 438 648

Brazil

Power Packer do Brasil Ltda.
Rua dos Inocentes, 587
04764-050 - Sao Paulo (SP)
Tel: +55 11 5687 2211
Fax: +55 11 5686 5583
Toll Free in Brazil:
Tel: 0800 891 5770
vendasbrasil@enerpac.com

Canada

Actuant Canada Corporation
6615 Ordan Drive, Unit 14-15
Mississauga, Ontario L5T 1X2
Tel: +1 905 564 5749
Fax: +1 905 564 0305
Toll Free:
Tel: +1 800 268 4987
Tel: +1 800 461 2456
Technical Inquiries:
techservices@enerpac.com

China

Actuant China Ltd.
1F, 269 Fute N. Road
Waigaoqiao Free Trade Zone
Pudong New District
Shanghai, 200 131 China
Tel: +86 21 5866 9099
Fax: +86 21 5866 7156

Actuant China Ltd. (Beijing)

709B Diyang Building
Xin No. 2
Dong San Huan North Rd.
Beijing City
100028 China
Tel: +86 10 845 36166
Fax: +86 10 845 36220

Central and Eastern Europe, Greece

ENERPAC B.V.
Galvanistraat 115
P.O. Box 8097
6710 AB Ede
The Netherlands
Tel: +31 318 535 936
Fax: +31 318 535 951

France, Switzerland francophone

ENERPAC
Une division de ACTUANT
France S.A.
B.P. 200, Parc d'Activités
du Moulin de Massy
F-91882 Massy CEDEX France
Tel: +33 1 60 13 68 68
Fax: +33 1 69 20 37 50

◆ e-mail: info@enerpac.com

Germany, Austria, Greece and Switzerland

ENERPAC GmbH
P.O. Box 300113
D-40401 Düsseldorf
Germany
Tel: +49 211 471 490
Fax: +49 211 471 49 28

India

ENERPAC Hydraulics
(India) Pvt. Ltd.
Office No. 9, 10 & 11,
Plot No. 56, Monarch Plaza,
Sector 11, C.B.D. Belapur
Navi Mumbai 400614, India
Tel: +91 22 2756 6090
Tel: +91 22 2756 6091
Fax: +91 22 2756 6095

Italy

ENERPAC S.p.A.
Via Canova 4
20094 Corsico (Milano)
Tel: +39 02 4861 111
Fax: +39 02 4860 1288

Japan

Applied Power Japan Ltd.
Besshochou 85-7
Saitama-shi, Kita-ku,
Saitama 331-0821
Japan
Tel: +81 48 662 4911
Fax: +81 48 662 4955

Middle East, Turkey and Caspian Sea

ENERPAC Middle East FZE
P.O. Box 18004
Jebel Ali, Dubai
United Arab Emirates
Tel: +971 (0)4 8872686
Fax: +971 (0)4 8872687

Russia and CIS

(excl. Caspian Sea Countries)

Actuant LLC
Admiral Makarov Street 8
125212 Moscow, Russia
Sector 11, C.B.D. Belapur
Navi Mumbai 400614, India
Tel: +7-495-9809091
Fax: +7-495-9809092

Singapore

Actuant Asia Pte. Ltd.
25 Serangoon North Ave. 5
#03-01 Keppel Digihub
Singapore 554914
Thomson Road
P.O. Box 114
Singapore 915704
Tel: +65 64 84 5108
+65 64 84 3737
Fax: +65 64 84 5669
Toll Free: +1800 363 7722
Technical Inquiries:
techsupport@enerpac.com.sg

South Korea

Actuant Korea Ltd.
3Ba 717,
Shihwa Industrial Complex
Jungwang-Dong, Shihung-Shi,
Kyunggi-Do
Republic of Korea 429-450
Tel: +82 31 434 4506
Fax: +82 31 434 4507

◆ internet: www.enerpac.com

Spain and Portugal

ENERPAC
C/San José Artesano 8
Pol. Ind.
28108 Alcobendas
(Madrid) Spain
Tel: +34 91 661 11 25
Fax: +34 91 661 47 89

The Netherlands, Belgium, Luxembourg, Sweden, Denmark, Norway, Finland and Baltic States

ENERPAC B.V.
Galvanistraat 115
P.O. Box 8097, 6710 AB Ede
The Netherlands
Tel: +31 318 535 911
Fax: +31 318 525 613
+31 318 535 848

Technical Inquiries Europe:

techsupport.europe@enerpac.com

United Kingdom, Ireland

Enerpac Ltd
Bentley Road South
Darlaston, West Midlands
WS10 8LQ, United Kingdom
Tel: +44 (0)121 50 50 787
Fax: +44 (0)121 50 50 799

USA, Latin America and Caribbean

ENERPAC
P.O. Box 3241
6100 N. Baker Road
Milwaukee, WI 53209 USA
Tel: +1 262 781 6600
Fax: +1 262 783 9562

Inquiries/orders:

+1 800 558 0530

Technical Inquiries:

techservices@enerpac.com

All Enerpac products are guaranteed against defects in workmanship and materials for as long as you own them. For your nearest authorized Enerpac Service Center, visit us at www.enerpac.com

05/2017

For Date Codes Beginning with the Letter "C"

油圧作動油はエナパック純正作動油をご使用下さい。
 修理された製品の最高の性能を保証するために、エナパック純正部品をご使用下さい。

部品図

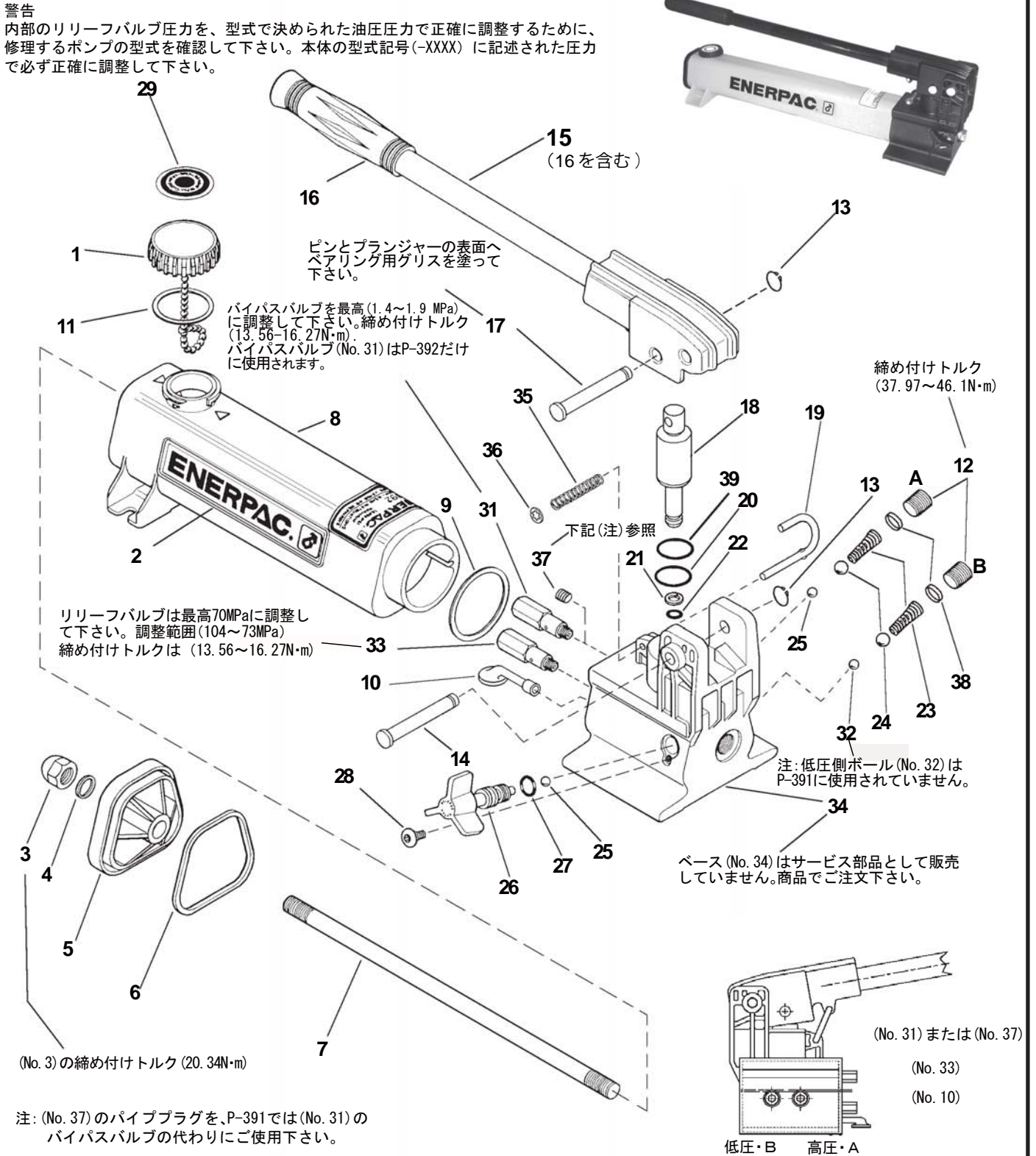

ENERPAC 

POWERFUL SOLUTIONS. GLOBAL FORCE.

部 品 表**P-391 ・ P-392**

05/2017

For Date Codes Beginning with the Letter "C"

油圧作動油はエナパック純正作動油をご使用下さい。
 修理された製品の最高の性能を保証するために、エナパック純正部品をご使用下さい。

(部品図を参照)

No.	部品番号	数量	部品名	No.	部品番号	数量	部品名
1	CN766950SR	1	ベントキャップ(含・11, 29)	19	CM927061SR	1	ロックピン(含・35, 36)
2	★	1	エナパックディケール	20	★	1	O-リング
3	CL341055	1	アコムナット	21	★	1	バックアップリング
4	★	1	ガスケット	22	★	1	O-リング
5	CN814020SR	1	エンドキャップ(含・3, 4, 6)	23	★	2	スプリング
6	★	1	ガスケットO-リング	24	★	2	5/16"ボール
7	CL127149	1	タイロッド	25	★	2	7/32"ボール
8	CR72025SR	1	リザーバー (黄色含・2, 3, 4, 6, 9, 11)	26	CL913900SR	1	スプリングアセンブリ(含・25, 27, 28)
	S95032025	1	リザーバー(赤色含・2, 3, 4, 6, 9, 11)	27	★	1	O-リング
9	★	1	ガスケット	28	★	1	スクリュウ
10	DA3729900SR	1	オイルフィルター	29	★	1	ベントキャップディケール
11	★	1	ガスケット	31	DA5493900SR	1	バイパスバルブ(P-392用)
12	CN815006	2	パイププラグ	32	★	1	7/32"チェックボール(P-392用)
13	★	2	リテーニングリング	33	DA8802900SR	1	リリーフバルブ
14	★CR214061SR	1	ビームピン(含・13)	34	商品で注文	1	ベース(部品で供給できません。)
15	CL918900SR	1	ビーム・ハンドルアセンブリ(含・16)	35	★	1	スプリング
16	CL343550	1	ハンドルグリップ	36	★	1	リテーニングリング
17	DC106061SR1	1	クロスピン(含・13)	37	A1006245	1	パイププラグ(P-391用)
18	CR333040SR	1	プランジャーアセンブリ(含・13, 17, 21, 22)	38	★	2	スプリングキャップ
				39	★	1	ワイパー

★印の部品はパッキンキット (P391K2) に含まれています。個別で部品供給はできません。

注・バイパスバルブの(No. 31)とチェックボール(No. 32)は型式P-391(1段吐出ポンプ)で使用しません。
(No. 31)の代わりに(No. 37)を使用して下さい。

POWERFUL SOLUTIONS. GLOBAL FORCE.

Japan Web サイト

エナパック株式会社

カスタマーサービス部

埼玉県さいたま市北区别所町85-7 〒331-0821

TEL.048-662-4911(代表) FAX.048-662-4955

E-Mailアドレス : info@enerpac.co.jp

<http://www.enerpac.co.jp>

お問い合わせ・ご用命は

●この部品表の内容は、予告なく変更されることがありますのでご了承ください。