

| Document Number | Document Revision | Document Revision Date | Product Date Code Beginning With |
|-----------------|-------------------|------------------------|----------------------------------|
| L4159 | A | 03/2016 | A |

NOTICE:

Enerpac recommends the installation of all parts included in a service assembly or repair kit to ensure optimum performance of the repaired product.

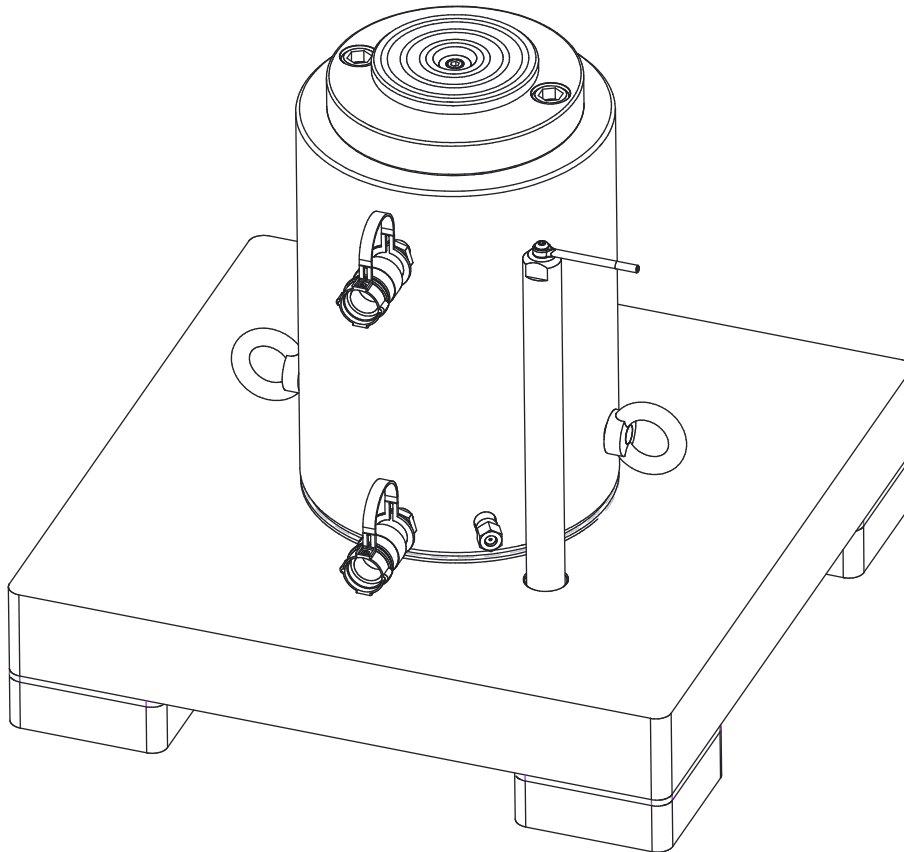

⚠ WARNING Fully relieve hydraulic pressure and disconnect hydraulic hoses before beginning any maintenance, repair or inspection procedures. Failure to observe these precautions could result in death or serious personal injury.

Fig. 1, Main Assembly

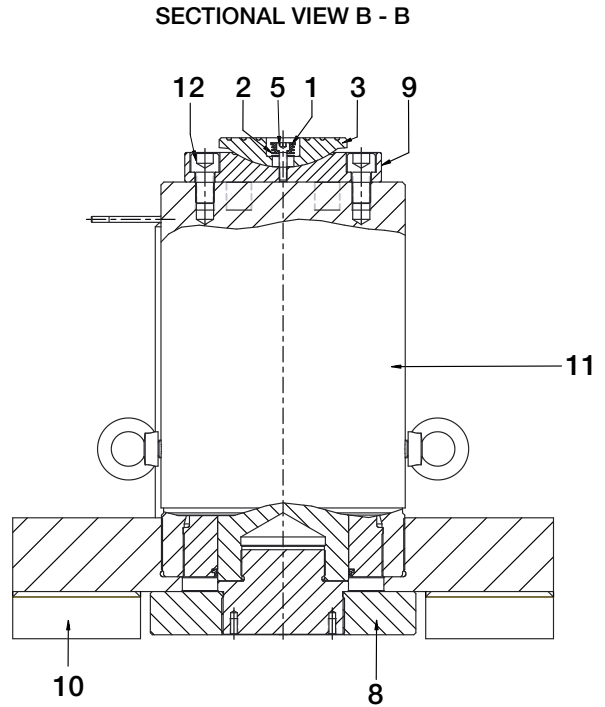
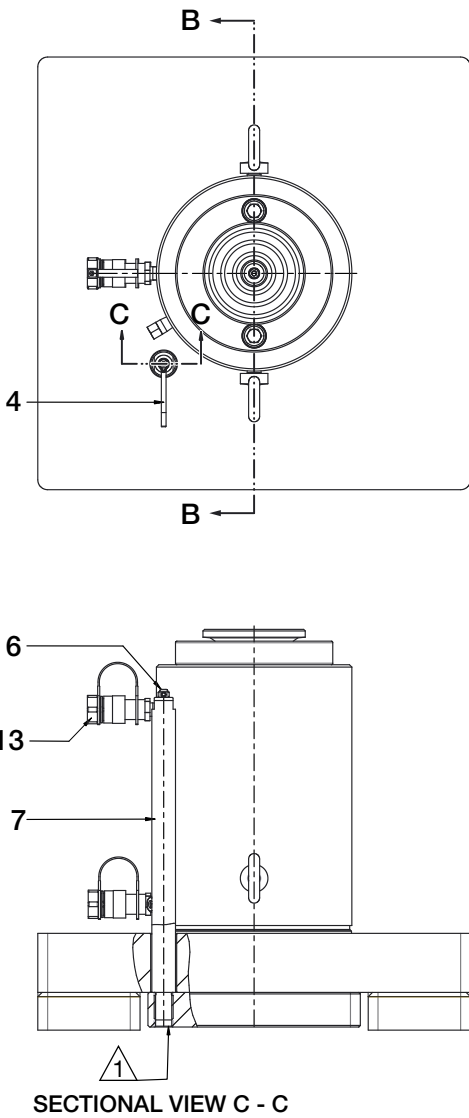

NOTES:

⚠ Apply Loctite 222 to threads of anti-rotation rod.

Assembly Instructions:

- a) Screw cylinder assembly into base plate until the end of the thread is reached.
- b) Unscrew the cylinder until the couplers are in the correct position.
- c) Extend the plunger.
- d) Assemble the plunger plate until the end of the thread is reached.
- e) Rotate plunger and plate to align the holes for the anti-rotation rod.
- f) Apply Loctite 222 to threads and assemble the anti-rotation rod.

Repair Parts List, Fig. 1

L4159

| Item | Part Number | Qty. | Description | Item | Part Number | Qty. | Description |
|------|--------------|------|---------------------|------|-------------|------|-----------------------|
| 1 | BSS2630D | 1 | Spring Guide | 9 | CV829045 | 1 | Under Saddle |
| 2 | BSS2635D | 1 | Spring | 10 | CV833101 | 1 | Plate, Base |
| 3 | BSS4026D | 1 | Upper Saddle (tilt) | 11 | CV846900 | 1 | Hydraulic Cylinder |
| 4 | CAB643028-4B | 1 | Cable Support Rod | 12 | CV850028 | 2 | Cap Screw, Socket Hd. |
| 5 | CBA825028-1A | 1 | Screw, SHC M80 x 25 | 13 | M229900 | 1 | Dust Cap |
| 6 | CBE621028-1E | 1 | Screw, BHCS M6 x 20 | 14 | ⊕ DA5117026 | 1 | Caution Warning Decal |
| 7 | CV817061 | 1 | Anti-Rotation Rod | 15 | ⊕ G425026 | 1 | Enerpac Decal |
| 8 | CV827900 | 1 | Plate, Plunger End | | | | |

Notes:

⊕ Item not shown.

Fig. 2, Hydraulic Cylinder

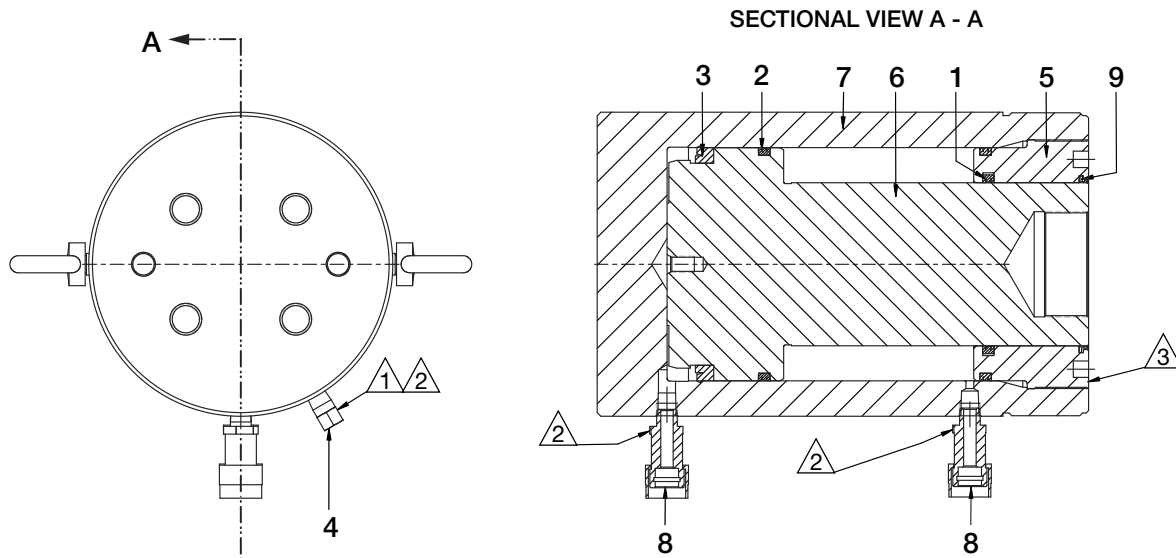

NOTES:

- ① Relief valve to be set to 723-758 bar [10,500-11,000 psi].
- ② Torque to 55 Nm [40 ft-lbs].
- ③ Apply Loctite 222 to threads and install stop ring in accordance with Enerpac Engineering Standard EES-5.

Repair Parts List, Fig. 2

L4159

| Item | Part Number | Qty. | Description | Item | Part Number | Qty. | Description |
|------|-------------|------|---------------------------|------|-------------|------|----------------|
| 1 | ★ B1431514 | 1 | Seal, GT Piston 5-1/4" ID | 6 | ★ CV845040 | 1 | Plunger |
| 2 | ★ B1441513 | 2 | Seal, GT Piston 7-1/2" OD | 7 | CZ268030 | 1 | Cylinder Base |
| 3 | ★ CH875041 | 1 | U-Cup | 8 | DC1389900 | 2 | Female Coupler |
| 4 | CJ160900W | 1 | Relief Valve | 9 | ★ M456044 | 1 | Wiper Ring |
| 5 | CM159044 | 1 | Stop Ring | | | | |

Notes:

- ★ Item included in RR2006K1 Repair Kit.
- Repair kit items are not sold separately.

Enerpac Worldwide Locations

✦ e-mail: info@enerpac.com

✦ internet: www.enerpac.com

Australia and New Zealand

Actuant Australia Ltd.
P.O. Box 6867
Wetherhill Park, NSW1851
Block V Unit 3
Regents Park Estate
391 Park Road
Regents Park NSW 2143
Australia
T +61 287 177 200
F +61 297 438 648
sales-au@enerpac.com

Brazil

Power Packer do Brasil Ltda.
Rua Luiz Lawrie Reid, 548
09930-760 - Diadema (SP) - Brazil
T +55 11 5687 2211
Toll Free: 0800 891 5770
ventasbrasil@enerpac.com

China (Taicang)

Actuant (China) Industries Co. Ltd.
No. 6 Nanjing East Road,
Taicang Economic Dep Zone
Jiangsu, China
T +86 0512 5328 7500
F +86 0512 5335 9690
Toll Free: +86 400 885 0369
sales-cn@enerpac.com

France, Switzerland, North Africa and French speaking African countries

ENERPAC
Une division d'ACTUANT France S.A.S.
ZA de Courtaboeuf
32, avenue de la Baltique
91140 VILLEBON /YVETTE
France
T +33 1 60 13 68 68
F +33 1 69 20 37 50
sales-fr@enerpac.com

Germany and Austria

ENERPAC GmbH
P.O. Box 300113
D-40401 Düsseldorf
Willstätterstrasse 13
D-40549 Düsseldorf, Germany
T +49 211 471 490
F +49 211 471 49 28
sales-de@enerpac.com

India

ENERPAC Hydraulics (India) Pvt. Ltd.
No. 10, Bellary Road, Sadashivanagar,
Bangalore, Karnataka 560 080
India
T +91 80 3928 9000
info@enerpac.co.in
www.enerpac.com

Italy

ENERPAC S.p.A.
Via Canova 4
20094 Corsico (Milano)
T +39 02 4861 111
F +39 02 4860 1288
sales-it@enerpac.com

Japan

Applied Power Japan LTD KK
Besshocho 85-7
Kita-ku, Saitama-shi 331-0821, Japan
T +81 48 662 4911
F +81 48 662 4955
sales-jp@enerpac.com

Middle East, Egypt and Libya

ENERPAC Middle East FZE
Office 423, LOB 15
P.O. Box 18004, Jebel Ali, Dubai
United Arab Emirates
T +971 (0)4 8872686
F +971 (0)4 8872687
sales-ua@enerpac.com

Russia

Rep. office Enerpac
Russian Federation
Admirala Makarova Street 8
125212 Moscow, Russia
T +7 495 98090 91
F +7 495 98090 92
sales-ru@enerpac.com

Southeast Asia, Hong Kong and Taiwan

Actuant Asia Pte Ltd.
83 Joo Koon Circle
Singapore 629109
T +65 68 63 0611
F +65 64 84 5669
Toll Free: +1800 363 7722
sales-sg@enerpac.com

South Korea

Actuant Korea Ltd.
3Ba 717, Shihwa Industrial Complex
Jungwang-Dong, Shihung-Shi,
Kyunggi-Do
Republic of Korea 429-450
T +82 31 434 4506
F +82 31 434 4507
sales-kr@enerpac.com

Spain and Portugal

ENERPAC SPAIN, S.L.
Avda. Los Frailes, 40 – Nave C & D
Pol. Ind. Los Frailes
28814 Daganzo de Arriba
(Madrid) Spain
T +34 91 884 86 06
F +34 91 884 86 11
sales-es@enerpac.com

Sweden, Denmark, Norway, Finland and Iceland

Enerpac Scandinavia AB
Kopparlundsvägen 14,
721 30 Västerås
Sweden
T +46 (0) 771 41 50 00
scandinavianinquiries@enerpac.com

The Netherlands, Belgium, Luxembourg, Central and Eastern Europe, Baltic States, Greece, Turkey and CIS countries

ENERPAC B.V.
Galvanistraat 115, 6716 AE Ede
P.O. Box 8097, 6710 AB Ede
The Netherlands
T +31 318 535 911
F +31 318 535 848
sales-nl@enerpac.com

Enerpac Integrated Solutions B.V.

Spinelstraat 15, 7554 TS Hengelo
P.O. Box 421, 7550 AK Hengelo
The Netherlands
T +31 74 242 20 45
F +31 74 243 03 38
integratedsolutions@enerpac.com

South Africa and other English speaking African countries

Enerpac Africa Pty Ltd.
No. 5 Bauhinia Avenue
Cambridge Office Park
Block E
Highveld Techno Park
Centurion 0157
Republic of South Africa
T: +27 12 940 0656
sales-za@enerpac.com

United Kingdom and Ireland

ENERPAC UK Ltd.
5 Coopies Field
Morpeth, Northumberland
NE61 6JR, England
T +44 1670 5010 00
sales-uk@enerpac.com

USA, Latin America and Caribbean

ENERPAC World Headquarters
P.O. Box 3241
Milwaukee WI 53201-3241 USA
N86 W12500 Westbrook Crossing
Menomonee Falls, Wisconsin 53051
T +1 262 293 1600
F +1 262 293 7036
User inquiries:
T +1 800 433 2766
Distributor inquiries/orders:
T +1 800 558 0530
F +1 800 628 0490
Technical inquiries:
techservices@enerpac.com
sales-us@enerpac.com

All Enerpac products are
guaranteed against defects
in workmanship and materials
for as long as you own them.

For the location of your nearest
authorized Enerpac Service Center,
visit us at www.enerpac.com

030316

ENERPAC

Visit www.enerpac.com for the location of the
Enerpac Authorized Service Center nearest you.