

Document Number	Document Revision	Document Revision Date	Product Date Code Beginning With
L4207	B	11/2017	A

**NOTICE:**

Enerpac recommends the installation of all parts included in a service assembly or repair kit to ensure optimum performance of the repaired product.

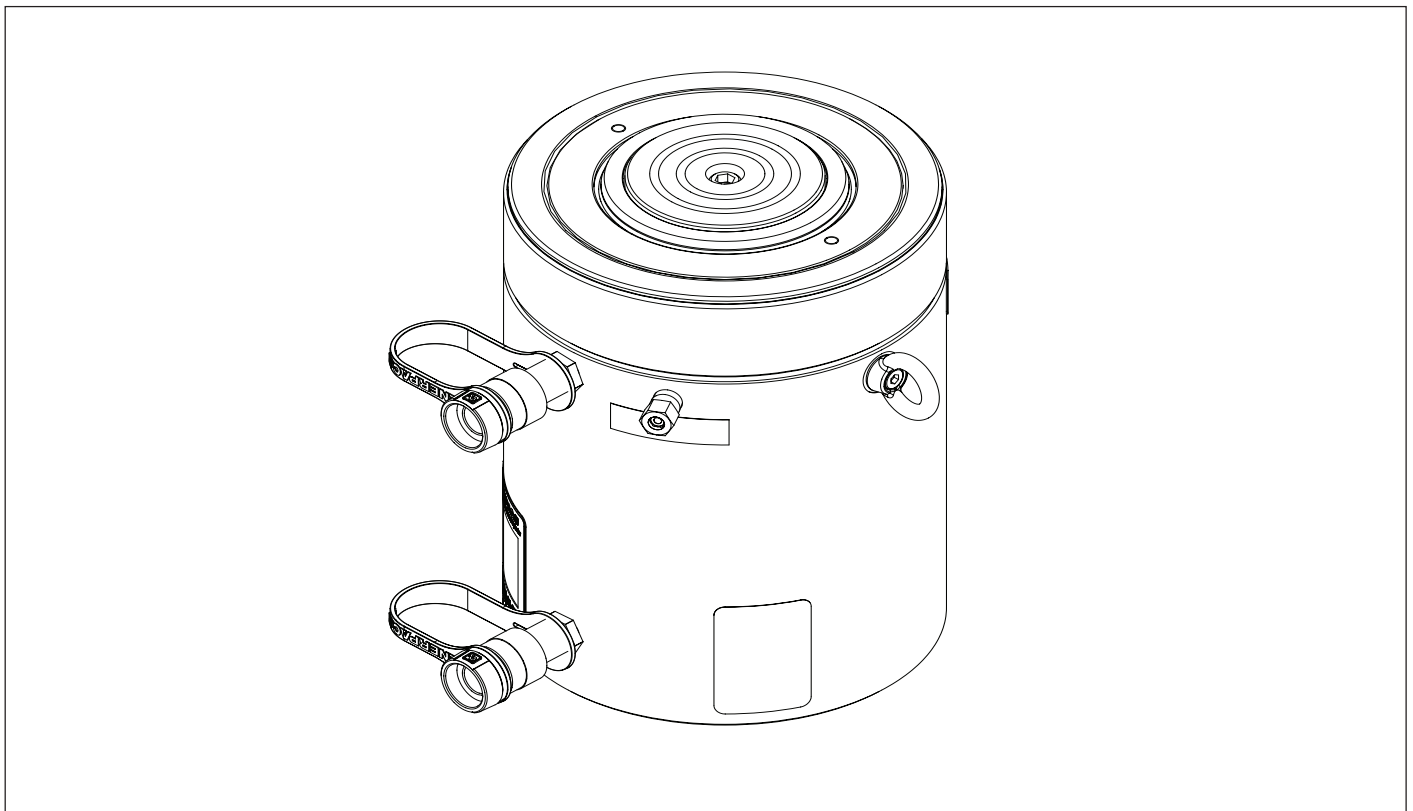
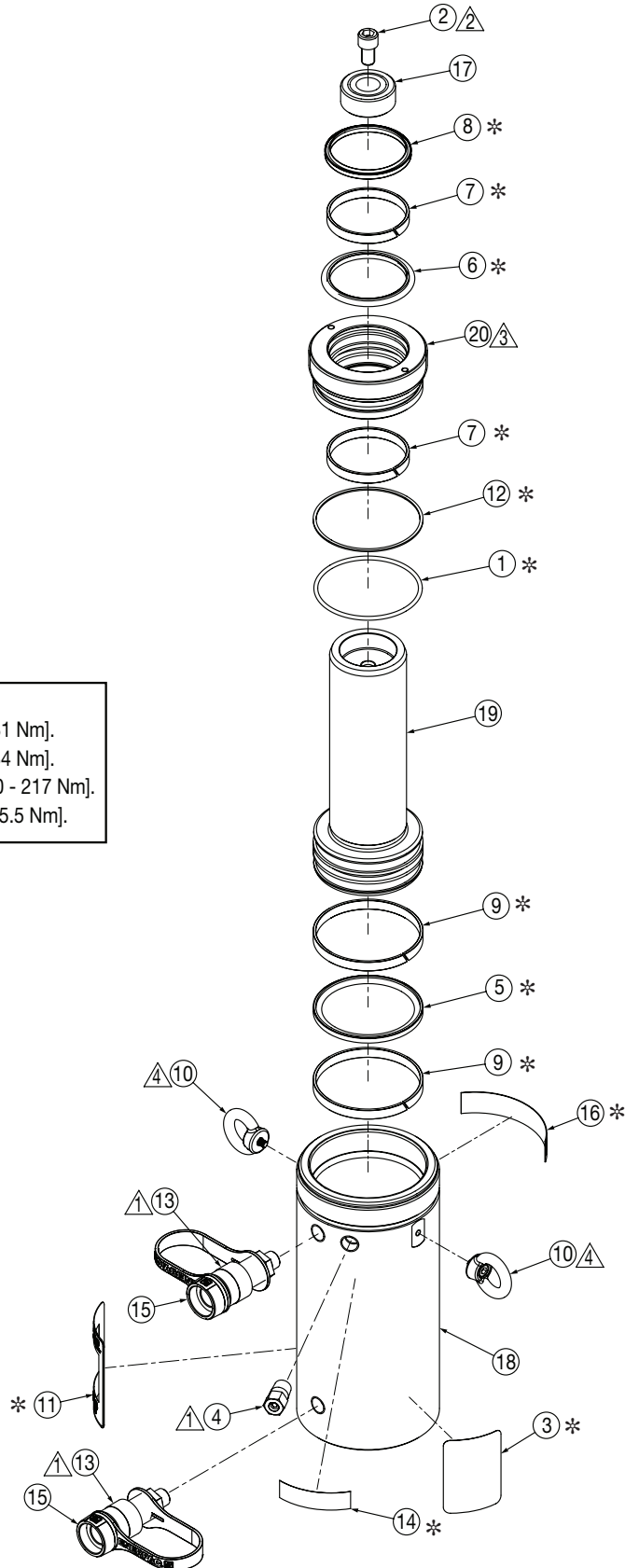

**Table of Contents:**

	Page		Page
Figure 1, Model HCR-50 Short .....	2-3	Figure 3, Model HCR-100 Short .....	6-7
Figure 2, Model HCR-50 Tall .....	4-5	Figure 4, Model HCR-100 Tall .....	8-9

**Figure 1, Exploded View - Model HCR-50 Short**

- Notes:**
- ⚠ Torque to 40 - 60 ft-lbs [55 - 81 Nm].
  - ⚠ Torque to 15 - 25 ft-lbs [20 - 34 Nm].
  - ⚠ Torque to 140 - 160 ft-lbs [190 - 217 Nm].
  - ⚠ Torque to 40 - 50 in-lbs [3.5 - 5.5 Nm].



**Repair Parts List for Figure 1**

<b>Item</b>	<b>Part Number</b>	<b>Qty.</b>	<b>Description</b>
1	* B1105503	1	O-Ring 91,67 x 3,53 Dash 239
2	CBE1221028-1A	1	M12 x 20 Long SHCS
3	* DA5625026	1	Warning Decal, 2.19" x 3.18"
4	DB8049900	1	Relief Valve Assembly
5	* DB8051076	1	Piston Seal 100 x 84,5 x 6,3
6	* DB8052076	1	Rod Seal 70 x 85,1 x 6,3
7	* DB8054155	2	Bearing, Rod 70 x 9,7
8	* DB8055776	1	Wiper 70 mm
9	* DB8056155	2	Bearing, Piston 100 x 9,7
10	DB8099667	2	Eyebolt, Rotating, M6
11	* DB8100026	1	Decal, Product Specification
12	* DB8119565	1	Back Up Ring 100 x 94,6 x 1,4
13	CR400	2	Female Coupler
14	* DC6154026	1	Decal, Safety Warning
15	CD411D	2	Dust Cap
16	* DD2459026	1	Decal, Enerpac
17	HCR50045	1	Saddle HCR 50 Ton
18	N/A	1	Base HCG/HCR 50 Ton 50 mm
	N/A	1	Base HCG/HCR 50 Ton 100 mm
	N/A	1	Base HCG/HCR 50 Ton 150 mm
19	HCR502040	1	Plunger HCG/HCR 50 Ton 50 mm
	HCR504040	1	Plunger HCG/HCR 50 Ton 100 mm
	HCR506040	1	Plunger HCG/HCR 50 Ton 150 mm
20	HCR502044	1	Stop Ring HCG/HCR 50 Ton Short

\* Included in HCR50K1 Seal Kit. N/A - Not Available.

**Figure 2, Exploded View - Model HCR-50 Tail**

- Notes:**
- △ Torque to 40 - 60 ft-lbs [55 - 81 Nm].
  - △ Torque to 15 - 25 ft-lbs [20 - 34 Nm].
  - △ Torque to 140 - 160 ft-lbs [190 - 217 Nm].
  - △ Torque to 40 - 50 in-lbs [3.5 - 5.5 Nm].

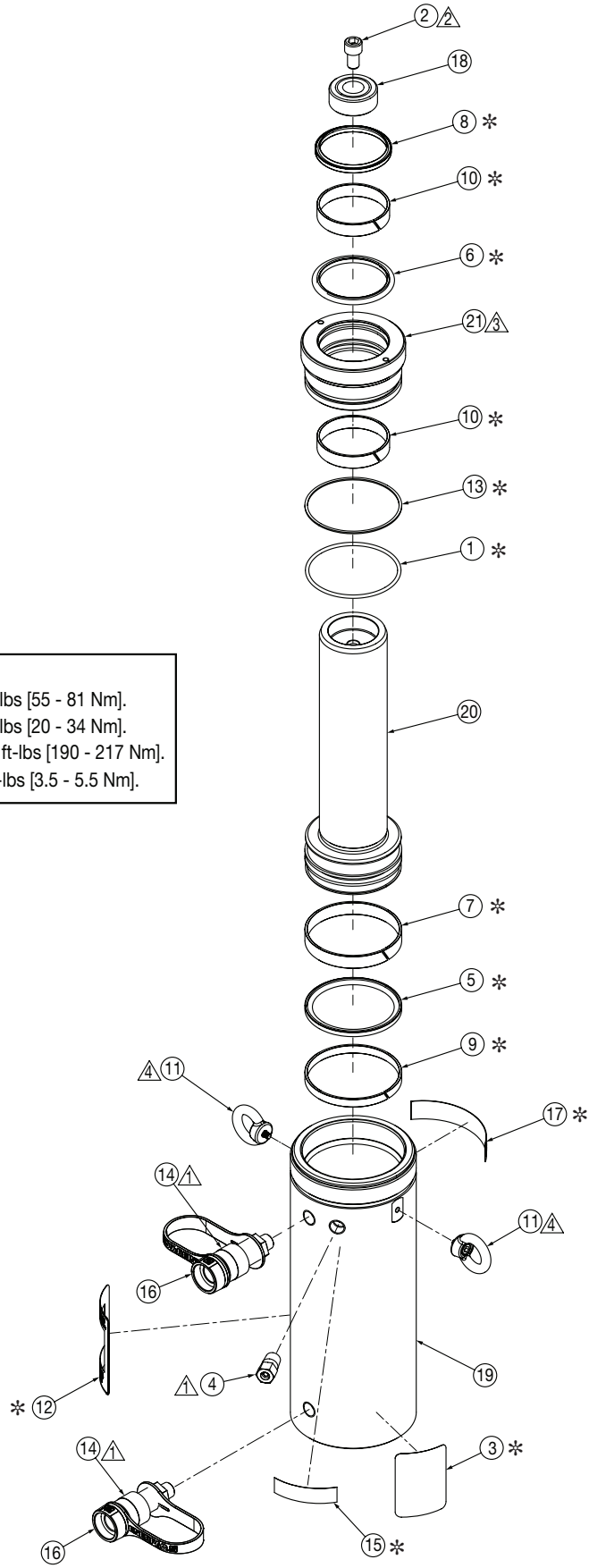

<b>Repair Parts List for Figure 2</b>			
<b>Item</b>	<b>Part Number</b>	<b>Qty.</b>	<b>Description</b>
1	* B1105503	1	O-Ring 91,67 x 3,53 Dash 239
2	CBE1221028-1A	1	M12 x 20 Long SHCS
3	* DA5625026	1	Warning Decal, 2.19" x 3.18"
4	DB8049900	1	Relief Valve Assembly
5	* DB8051076	1	Piston Seal 100 x 84,5 x 6,3
6	* DB8052076	1	Rod Seal 70 x 85,1 x 6,3
7	* DB8053155	1	Bearing, Piston 100 x 15
8	* DB8055776	1	Wiper 70 mm
9	* DB8056155	1	Bearing, Piston 100 x 9,7
10	* DB8057155	2	Bearing, Rod 70 x 15
11	DB8099667	2	Eyebolt, Rotating, M6
12	* DB8100026	1	Decal, Product Specification
13	* DB8119565	1	Back Up Ring 100 x 94,6 x 1,4
14	CR400	2	Female Coupler
15	* DC6154026	1	Decal, Safety Warning
16	CD411D	2	Dust Cap
17	* DD2459026	1	Decal, Enerpac
18	HCR50045	1	Saddle HCR 50 Ton
19	N/A	1	Base HCG/HCR 50 Ton 200 mm
	N/A	1	Base HCG/HCR 50 Ton 250 mm
	N/A	1	Base HCG/HCR 50 Ton 300 mm
20	HCR508040	1	Plunger HCG/HCR 50 Ton 200 mm
	HCR5010040	1	Plunger HCG/HCR 50 Ton 250 mm
	HCR5012040	1	Plunger HCG/HCR 50 Ton 300 mm
21	HCR508044	1	Stop Ring HCR 50 Ton Tall
* Included in HCR50K2 Seal Kit. N/A - Not Available.			

**Figure 3, Exploded View - Model HCR-100 Short**



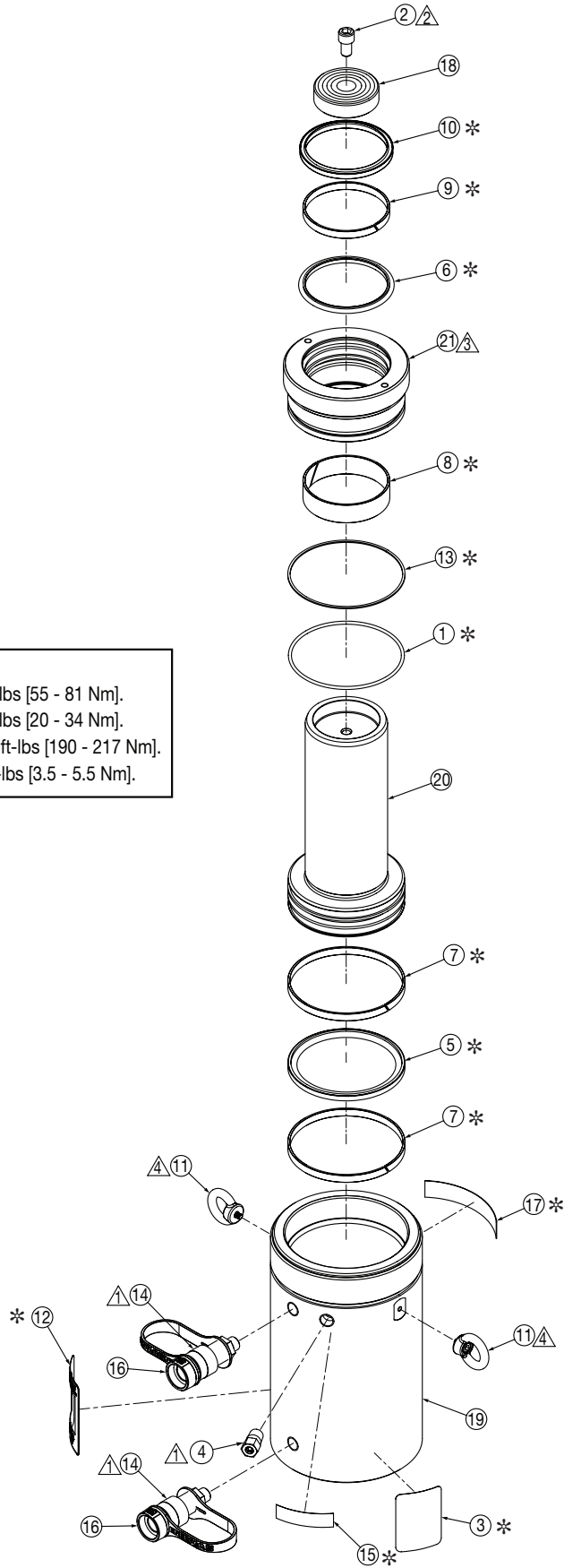

- Notes:**
- ⚠ Torque to 40 - 60 ft-lbs [55 - 81 Nm].
  - ⚠ Torque to 15 - 25 ft-lbs [20 - 34 Nm].
  - ⚠ Torque to 140 - 160 ft-lbs [190 - 217 Nm].
  - ⚠ Torque to 40 - 50 in-lbs [3.5 - 5.5 Nm].



**Repair Parts List for Figure 3**

<b>Item</b>	<b>Part Number</b>	<b>Qty.</b>	<b>Description</b>
1	* B1116503	1	O-Ring
2	CBE1221028-1A	1	M12 x 20 Long SHCS
3	* DA5625026	1	Warning Decal, 2.19" x 3.18"
4	DB8049900	1	Relief Valve Assembly
5	* DB8058076	1	Piston Seal 135 x 114 x 8,1
6	* DB8059076	1	Rod Seal 95 x 110,1 x 6,3
7	* DB8060155	2	Bearing, Piston 135 x 9,7
8	* DB8061155	1	Bearing, Rod 95 x 25
9	* DB8062155	1	Bearing, Rod 95 x 9,7
10	* DB8063776	1	Wiper 95 mm
11	DB8099667	2	Eyebolt, Rotating, M6
12	* DB8100026	1	Decal, Product Specification
13	* DB8125565	1	Back Up Ring 135 x 129,6 x 1,4
14	CR400	2	Female Coupler
15	* DC6154026	1	Decal, Safety Warning
16	CD411D	2	Dust Cap
17	* DD2459026	1	Decal, Enerpac
18	HCR100045	1	Saddle HCR 100 Ton
19	N/A	1	Base HCG/HCR 100 Ton 50 mm
	N/A	1	Base HCG/HCR 100 Ton 100 mm
	N/A	1	Base HCG/HCR 100 Ton 150 mm
20	HCR1002040	1	Plunger HCG/HCR 100 Ton 50 mm
	HCR1004040	1	Plunger HCG/HCR 100 Ton 100 mm
	HCR1006040	1	Plunger HCG/HCR 100 Ton 150 mm
21	HCR1002044	1	Stop Ring HCG/HCR 100 Ton Short
* Included in HCR100K1 Seal Kit. N/A - Not Available.			

**Figure 4, Exploded View - Model HCR-100 Tall**

- Notes:**
-  Torque to 40 - 60 ft-lbs [55 - 81 Nm].
  -  Torque to 15 - 25 ft-lbs [20 - 34 Nm].
  -  Torque to 140 - 160 ft-lbs [190 - 217 Nm].
  -  Torque to 40 - 50 in-lbs [3.5 - 5.5 Nm].

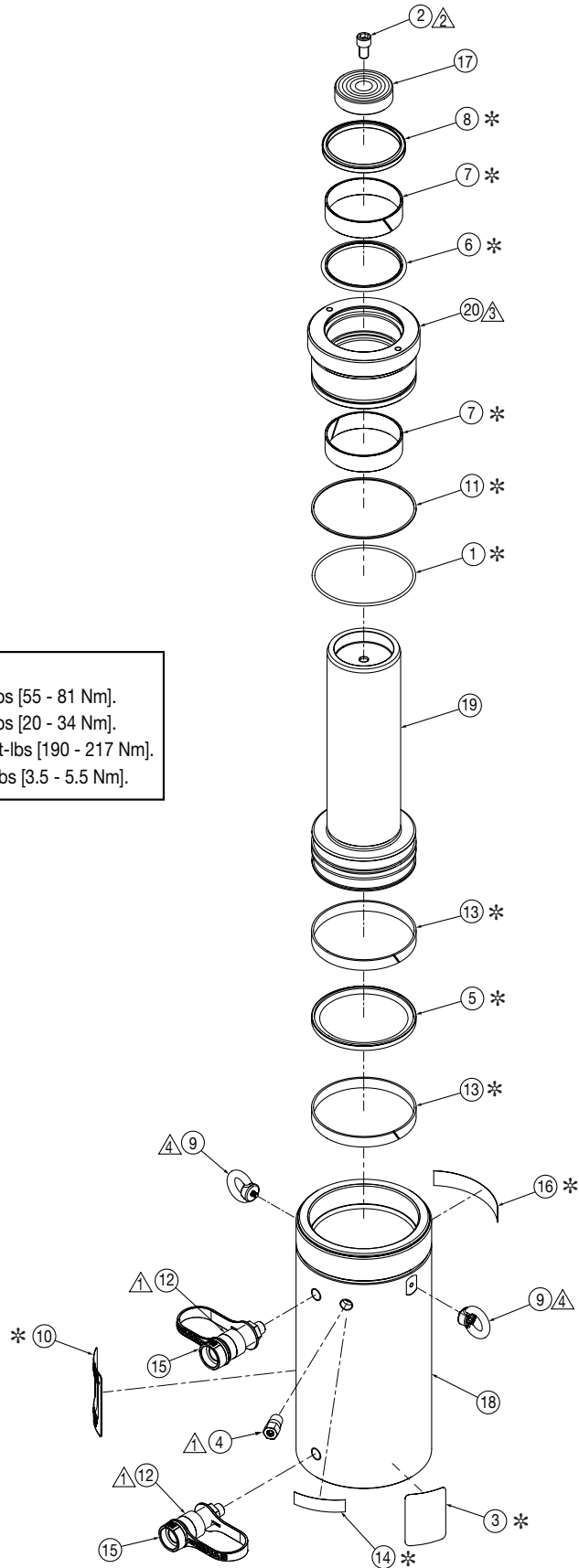



**Repair Parts List for Figure 4**

<b>Item</b>	<b>Part Number</b>	<b>Qty.</b>	<b>Description</b>
1	* B1116503	1	O-Ring
2	CBE1221028-1A	1	M12 x 20 Long SHCS
3	* DA5625026	1	Warning Decal, 2.19" x 3.18"
4	DB8049900	1	Relief Valve Assembly
5	* DB8058076	1	Piston Seal 135 x 114 x 8,1
6	* DB8059076	1	Rod Seal 95 x 110,1 x 6,3
7	* DB8061155	2	Bearing, Rod 95 x 25
8	* DB8063776	1	Wiper 95 mm
9	DB8099667	2	Eyebolt, Rotating, M6
10	* DB8100026	1	Decal, Product Specification
11	* DB8125565	1	Back Up Ring 135 x 129,6 x 1,4
12	CR400	2	Female Coupler
13	* DC5439155	2	Piston Wear Ring
14	* DC6154026	1	Decal, Safety Warning
15	CD411D	2	Dust Cap
16	* DD2459026	1	Decal, Enerpac
17	HCR100045	1	Saddle HCR 100 Ton
18	N/A	1	Base HCG/HCR 100 Ton 200 mm
	N/A	1	Base HCG/HCR 100 Ton 250 mm
	N/A	1	Base HCG/HCR 100 Ton 300 mm
19	HCR1008040	1	Plunger HCG/HCR 100 Ton 200 mm
	HCR10010040	1	Plunger HCG/HCR 100 Ton 250 mm
	HCR10012040	1	Plunger HCG/HCR 100 Ton 300 mm
20	HCR1008044	1	Stop Ring HCG/HCR 100 Ton Tall

\* Included in HCR100K2 Seal Kit. N/A - Not Available.



# NOTES:

A large rectangular box containing 20 horizontal lines for writing notes.

