



Repair Parts Sheet

E-Series Electric Torque Wrench Pump

Document Number	Document Revision	Document Revision Date	Product Date Code Beginning With
L4350	B	10/2019	A

To Protect Your Warranty, Use Only ENERPAC Hydraulic Oil.

Enerpac recommends that all kit components be installed to ensure optimum performance of the repaired product.

Models:

- EP3504TB and EP3504TB-M (100-120 VAC - NEMA 5-15 plug)
- EP3504TI and EP3504TI-M (200-250 VAC - NEMA 6-15 plug)
- EP3504TE and EP3504TE-M (200-250 VAC - Schuko CEE 7/7 plug)

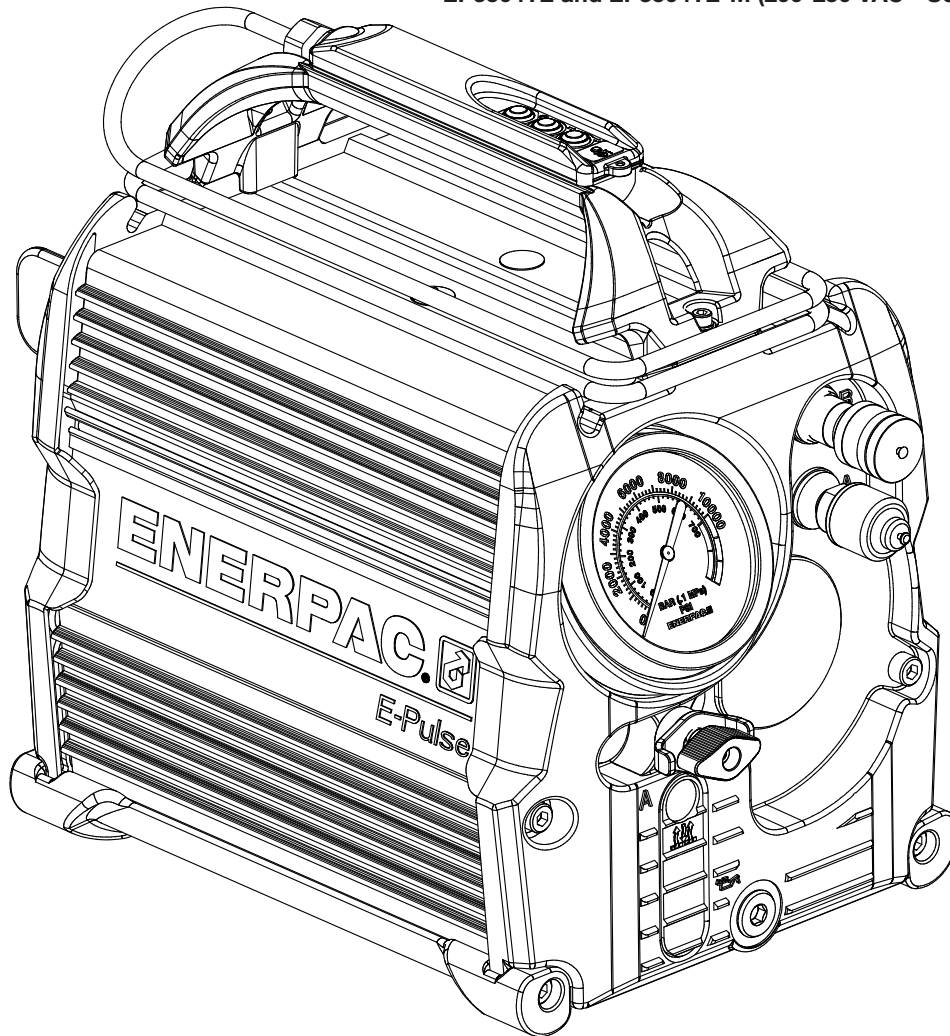

WARNING Fully relieve hydraulic pressure, disconnect hydraulic hoses and unplug AC power cord from electrical outlet before beginning any inspection, maintenance or repair procedures. Failure to observe these precautions could result in death or serious personal injury. Appropriate shop safety procedures are to be followed during disassembly and reassembly to minimize any possibility of injury.

Table of Contents:	Page
Figure 1, E-Series Torque Wrench Pump Main View.....	3
Figure 1A, DC Power Cable Assembly.....	4
Figure 1B, Serial Communications Cable Assembly.....	4
Figure 1C, Jumper Connection.....	5
Figure 2, Pendant Assembly.....	5
Figure 3, Power App Board Assembly.....	6
Figure 4, Motor Controller Assembly.....	7
Figure 5, Pump/Motor Assembly.....	8
Figure 5A, Motor Replacement Kit.....	10
Figure 6, Motor Replacement Kit.....	11
Figure 6A, Eccentric Kit.....	12
Figure 6B, Pump Housing Kit.....	13
Figure 6C, Piston Block Assembly Kits.....	14
Figure 6D, Piston Block Seal Kit.....	15
Figure 6E, Intake Suction Filter Kit.....	15
Figure 7, Major Components, Control Valve and Pump.....	16
Figure 7A, Control Valve Mounting Hardware and Hydraulic Connections.....	17
Figure 7B, Valve Assembly.....	18
Figure 7C, Direct Drive Pump Assembly.....	19
Figure 7D, Rebuild Kit, User-Adjustable Relief Valve (UARV).....	20
Figure 7E, Heat Exchanger Assembly.....	21
Figure 8, Reservoir Assembly.....	22
Figure 9, Front End Cap Assembly.....	23
Figure 10, Rear End Cap Assembly.....	24
Figure 10A, Power Cord Replacement Kit.....	25
Figure 11, Electrical Block Wiring Diagram.....	26
Figure 12, Hydraulic Schematic.....	27
Figure 13, Pump Cover Removal/Installation Instructions.....	28

Notes:

- Parts lists indicate the total quantity of each part used in a figure.
- The quantity of a part supplied in a repair kit or service assembly may be less than the total quantity shown in the parts list.
- Information contained in this document is subject to change without notice due to design variables, product improvements and other factors. Copyright © 2019 Enerpac. All rights reserved.

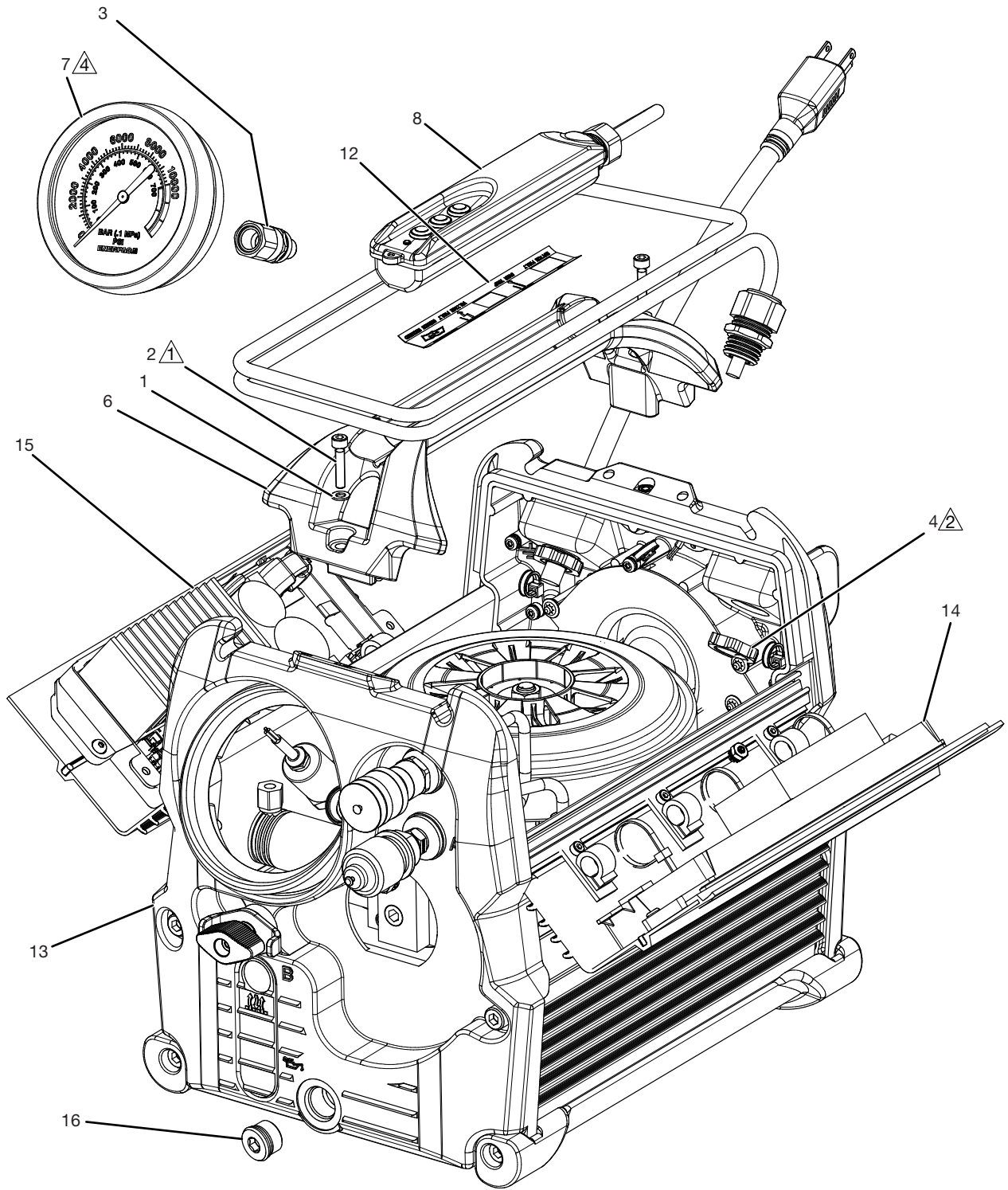

- ① Torque to 42-47 in-lbs [4.8-5.3 Nm].
- ② Torque to finger tight plus an additional 1/4 turn.
- ③ Apply NPTF tape, torque to 28-34 ft-lbs [38-46 Nm].
- ④ Torque to 13-16 ft-lbs [18-22 Nm].

Figure 1, E-Series Torque Wrench Pump - Main View

Repair Parts List for Figure 1				
Item	Part Number	Qty.	Description	
1	* CAE1050108-1A	2	Flat Washer	
2	* CCE523028-1A	2	Screw-SHCS, Hex	
3	CF773900	1	Half Coupler, Hose End	
4	DC9538021	1	Locking Nut 20mm	
5	DC9876647	3	Black Cable Tie 6"	
6	* DD6789800	1	Pump Handle	
7	DD6988223	1	Pressure Gauge	
8	see Figure 2	1	Pendant Assembly	
9	DD7061960	1	DC Power Supply Cable Assembly	
10	DD7064960	1	Serial Communications Cable Assembly	
11	DD7125960	2	J8 and J9 Connection Cable Jumper	
12	* DD7167026	1	Troubleshooting Decal	
13	see Figure 9	1	Front End Cap Assembly	
14	see Figure 3	1	Power App Board Assembly	
15	see Figure 4	1	Motor Controller Assembly	
16	DD7557006	1	Plug, SAE #8, Zero-Leak	

* Items are included in Pump Handle Service Kit, DD5789800SR.

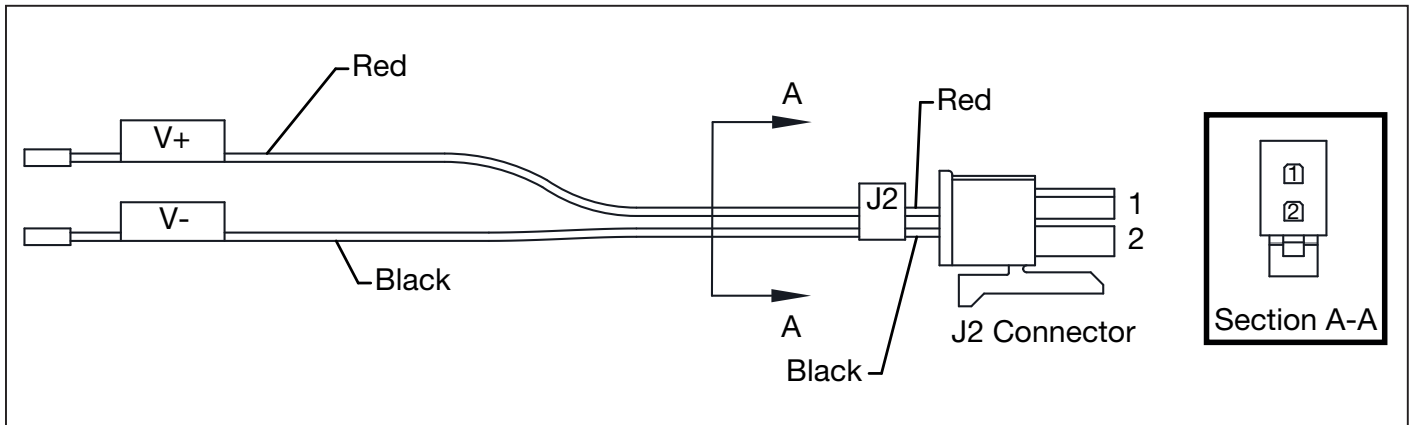

Figure 1A, DC Power Cable Assembly

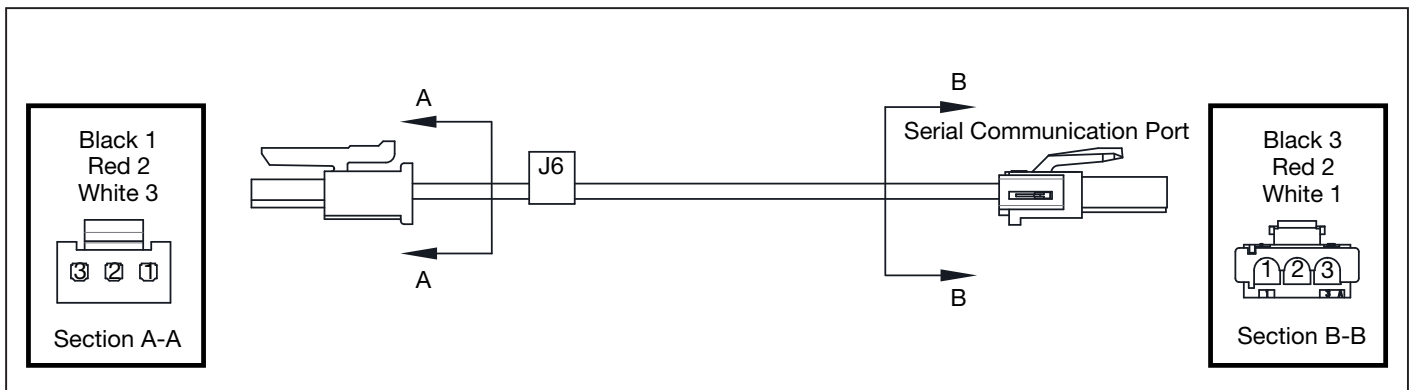

Figure 1B, Serial Communications Cable Assembly

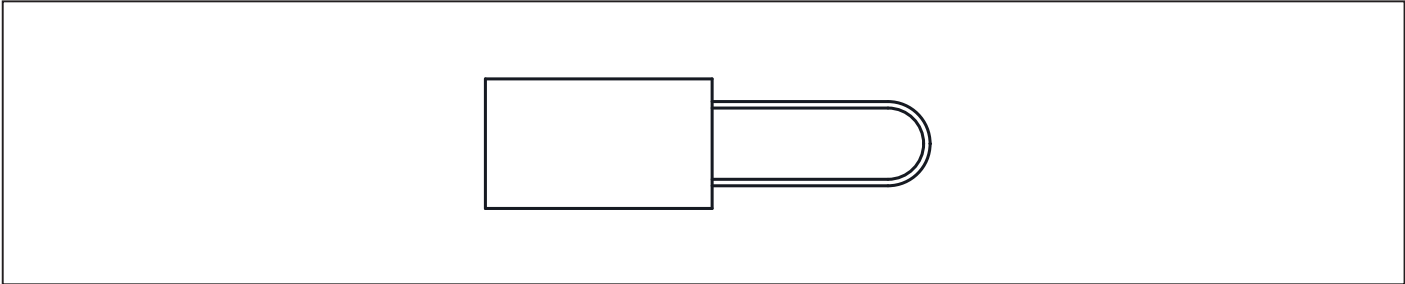

Figure 1C, Jumper Connection

Repair Parts List for Figure 1A, 1B and 1C			
Item	Part Number	Qty.	Description
6	DD7061960	1	Cable Assembly, DC Power Supply
7	DD7064960	1	Cable Assembly, Serial Communications
8	DD7125960	1	Cable, Jumper, J8 and J9 Connection
---	DC9876647	3	Black Cable Tie 6" (not shown)

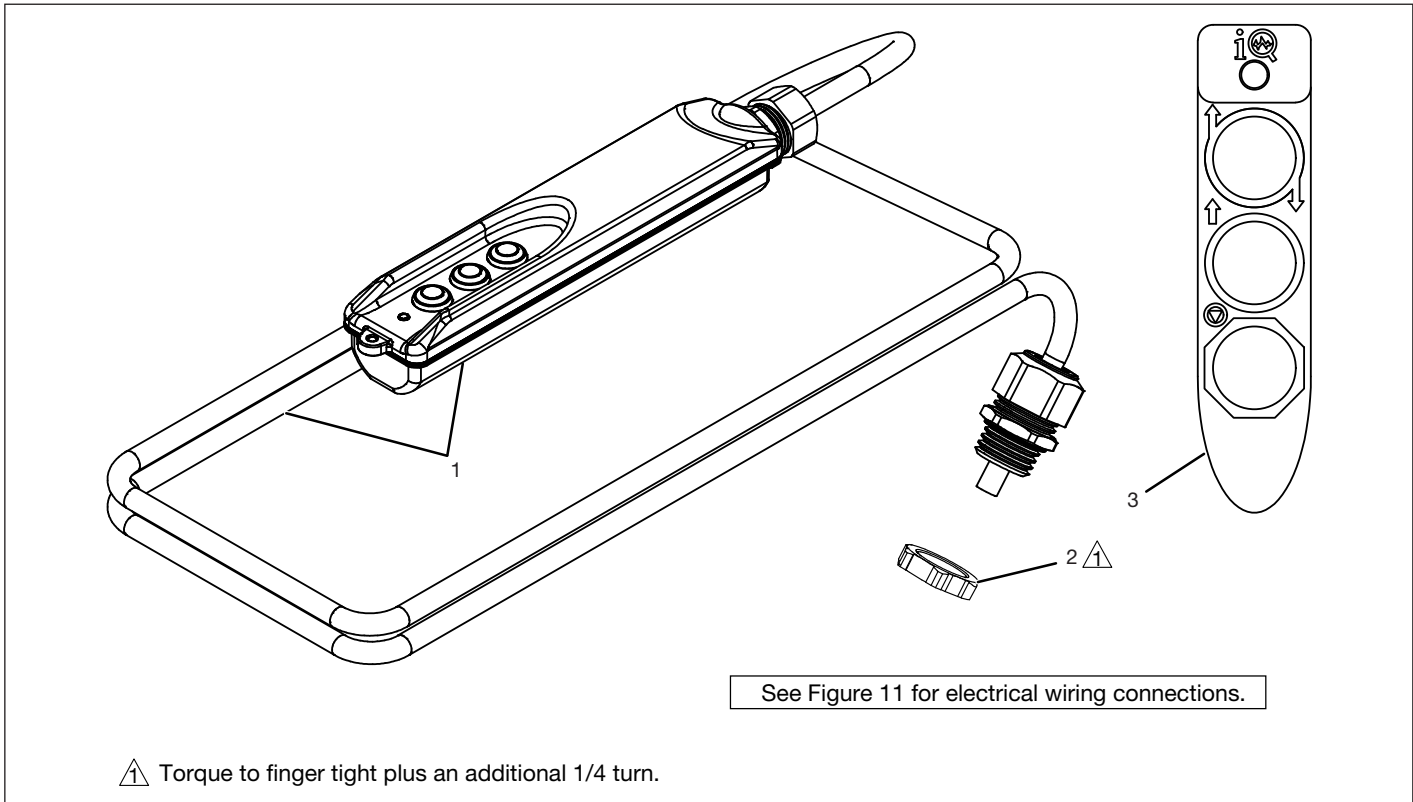

Figure 2, Pendant Assembly, Three Button

Repair Parts List for Figure 2			
Item	Part Number	Qty.	Description
1	* DD7016900	1	Pendant and Cable Assembly, 3 Button
2	* DC9538021	1	Locking Nut 20mm
3	* DD7348026	1	Decal, Pendant

* Items are included in Pendant Assembly Service Kit, DD7016900SR.

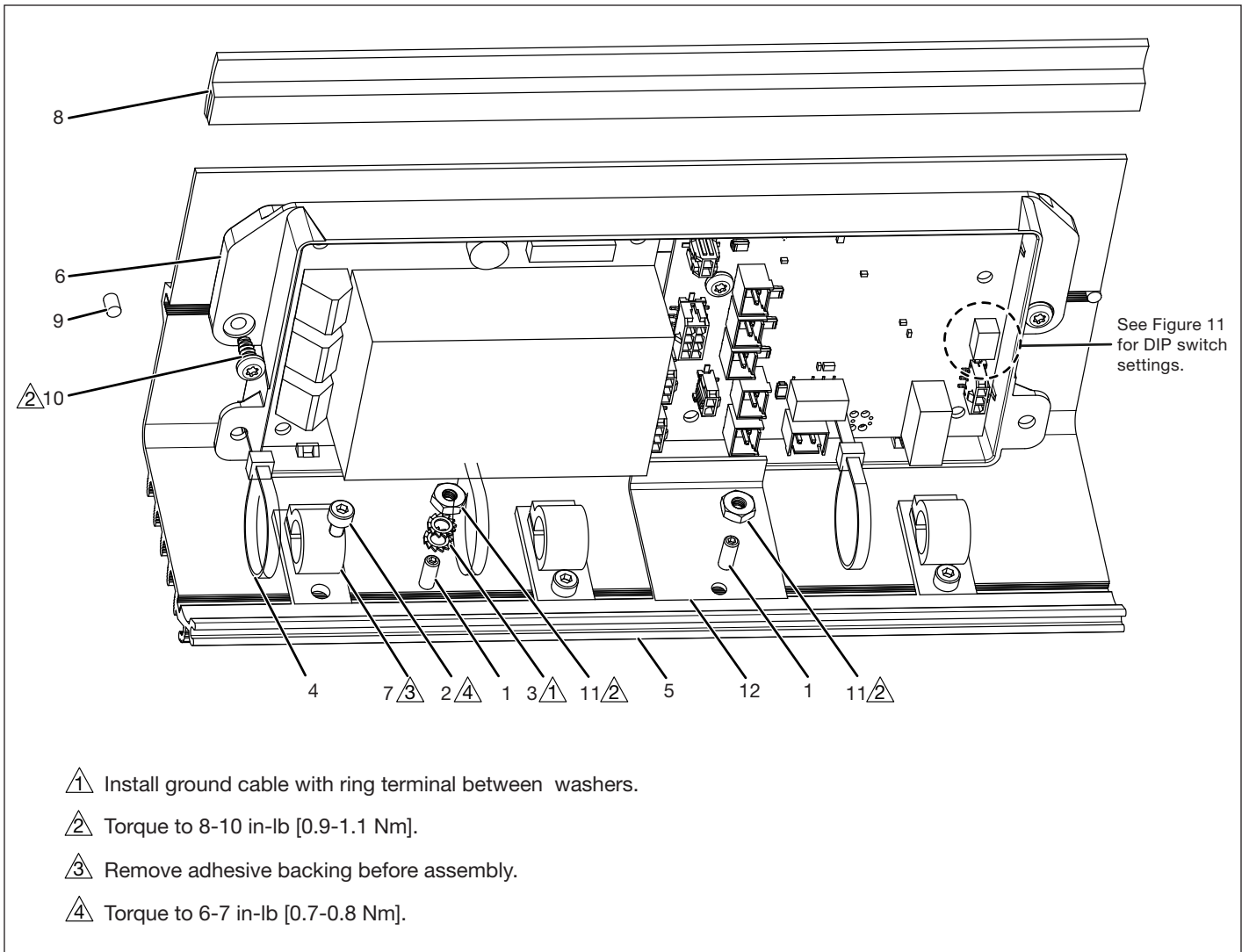
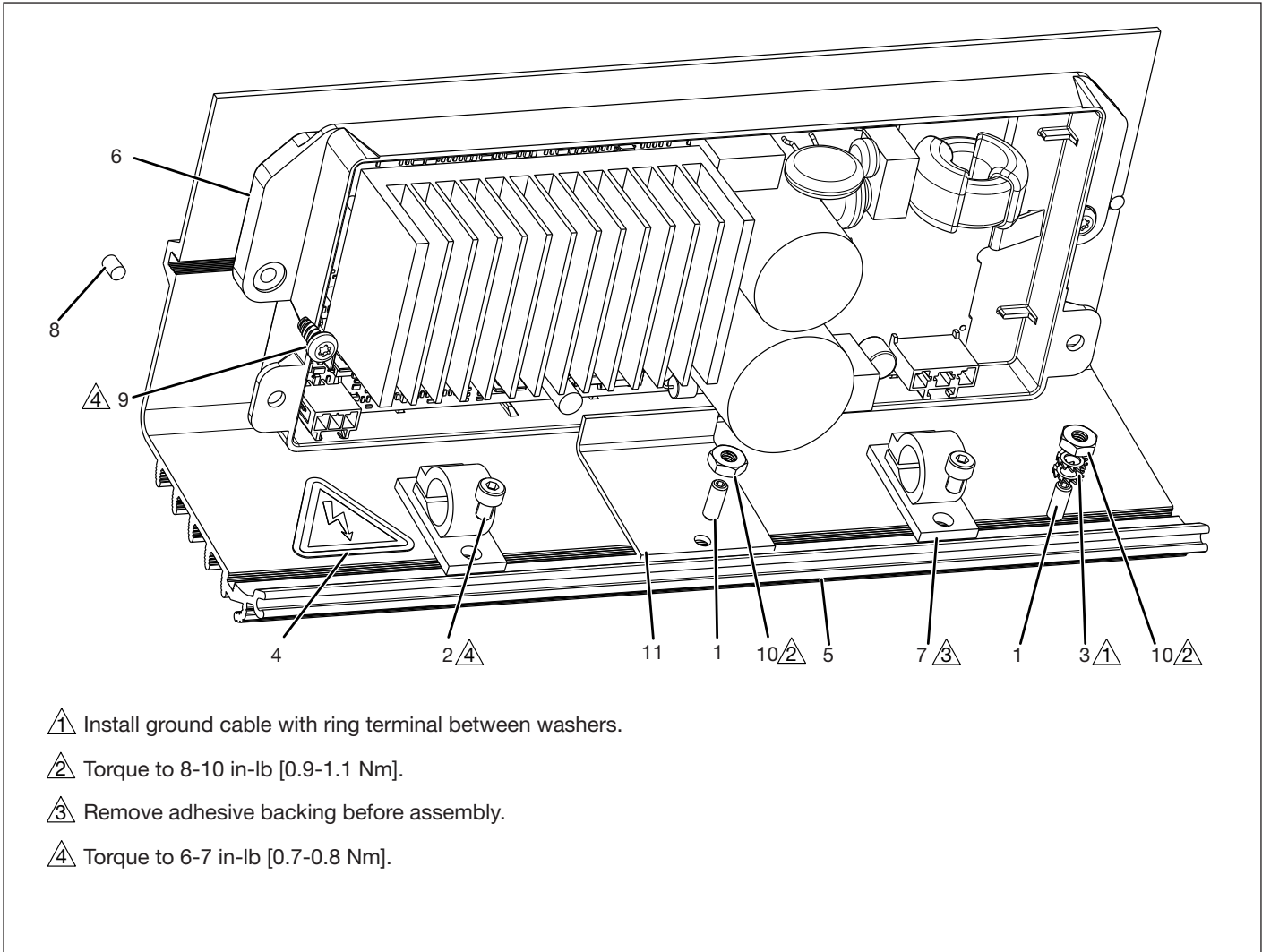

Figure 3, Power App Board Assembly

Repair Parts List for Figure 3			
Item	Part Number	Qty.	Description
1	BF1607027AX	2	Set Screw
2	CBE411028-1A	3	Hex Screw
3	CCE1040108-7A	2	Lock Washer
4	DC9876647	3	6" Cable Tie
5	DD6792098-P03	1	Cover
6	⊕ DD7298900	1	Power Board Assembly
7	DD7326217	3	Cable Tie
8	DD7448037	1	Lip Seal
9	* DD7462037	2	Gasket
10	⊕ DD7513001	2	Thread Forming Screw
11	DD7516122	2	Hex Nut
12	DD7609111	1	Bracket, Motor Controller Restraint

* Item is included in Water Ingress Seal Service Kit, EPWISK.

⊕ Items are included in Power App Board Assembly Service Kit, DD7298900K.



- ⚠ 1 Install ground cable with ring terminal between washers.
- ⚡ 2 Torque to 8-10 in-lb [0.9-1.1 Nm].
- ⚠ 3 Remove adhesive backing before assembly.
- ⚡ 4 Torque to 6-7 in-lb [0.7-0.8 Nm].

Figure 4, Motor Controller Assembly

Repair Parts List for Figure 4			
Item	Part Number	Qty.	Description
1	BF1607027AX	2	Set Screw
2	▼ CBE411028-1A	3	Hex Screw
3	CCE1040108-7A	2	Lock Washer
4	▼ DD9922026	1	Decal
5	▼ DD6792098-P03	1	Cover
6	DD6987827K	1	Motor Controller, 120V Kit, Models P3504TB and EP3504TB-M
	DD7318827K	1	Motor Controller, 240V Kit, Models EP3504TI, EP3504TI-M, EP3504TE and EP3504TE-M
7	▼ DD7326217	3	Cable Tie
8	▼ * DD7462037	2	Gasket
9	☆ DD7513001	2	Thread Forming Screw
10	DD7516122	2	Hex Nut
11	DD7609111	1	Bracket, Motor Controller Restraint
12	▼ DC7887026 (not shown)	1	Decal, CE Safety Label Read Instructions
13	▼ DD7417026 (not shown)	1	Decal, Unplug Cord Before Service

▼ Items are included in Pump Cover Service Kit, DD6792098SR.

☆ Item is included in Motor Controller Service Kits.

* Item is included in Water Ingress Seal Service Kit, EPWISK.

- 1 Insert tubes and torque to 150-160 in-lb [203-217 Nm] (At manifold end prior to installing pump into reservoir).
- 2 Apply Loctite 243.
- 3 Torque to 42-47 in-lb [4.7-5.3 Nm].
- 4 Bend tube vertical while install pump into reservoir.
- 5 Align mark on counterweight with drill point and key slot on shaft (see Detail C).
- 6 Torque to 32-39 ft-lbs [43-53 Nm].

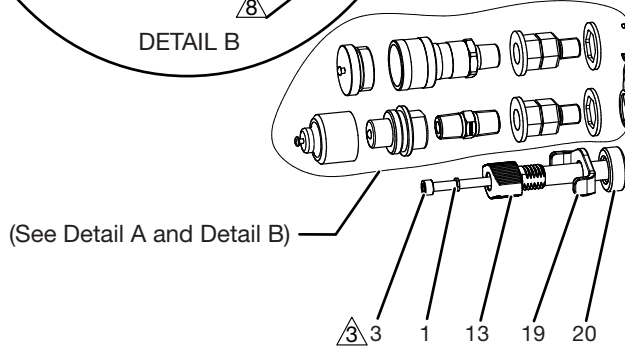
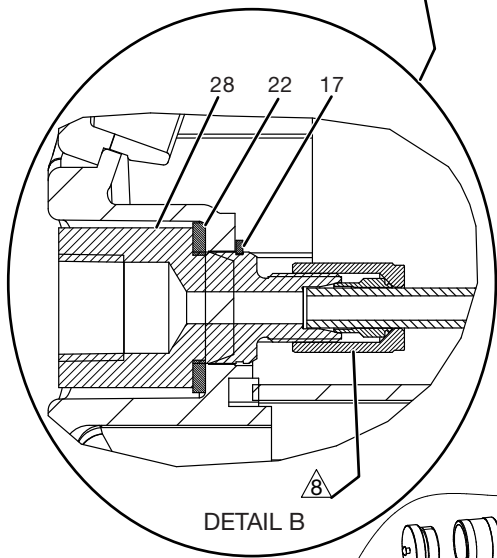
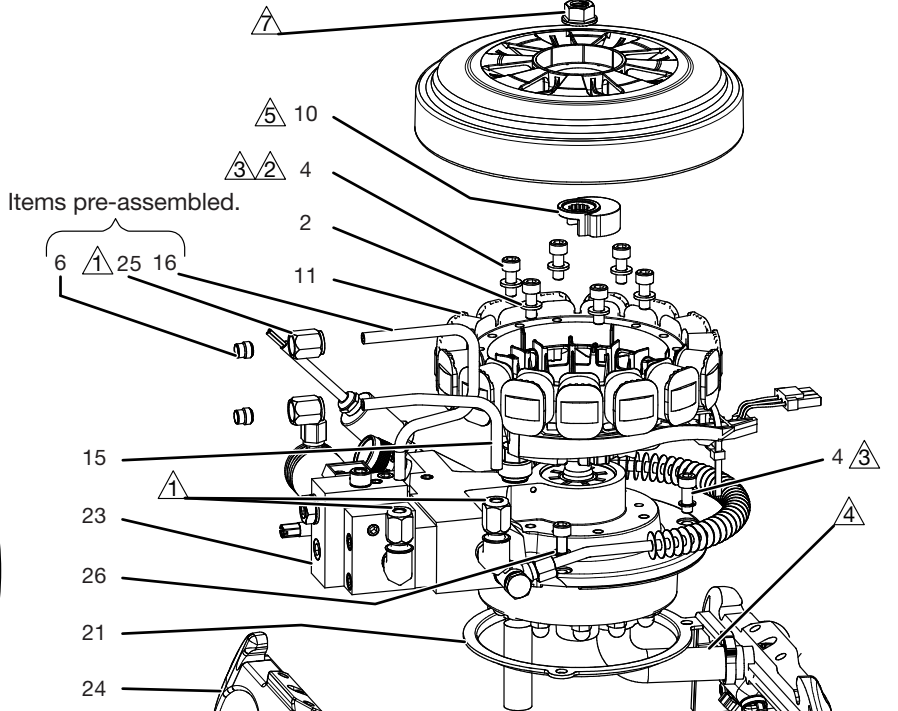
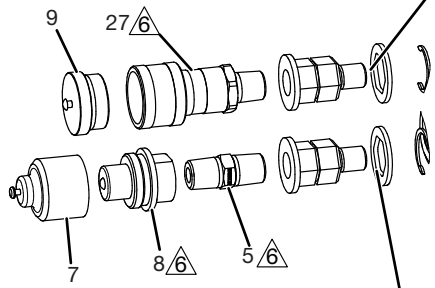
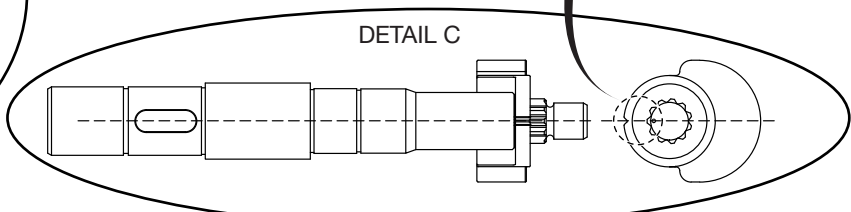
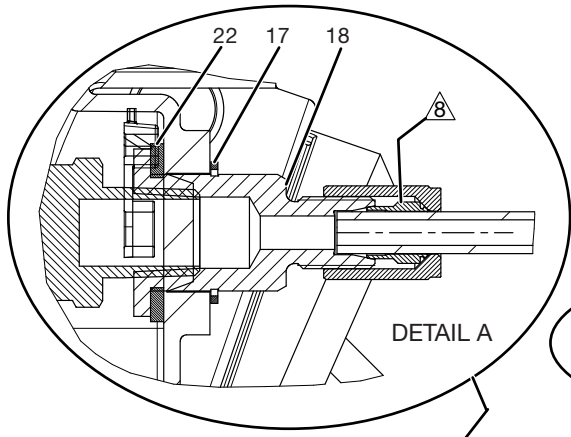
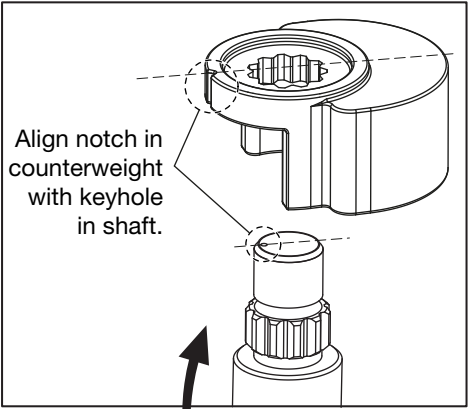

- 7 Torque to 100-120 ft-lbs [43-53 Nm].
- 8 Orient ferrule for compression fitting with small end OD toward tube end.

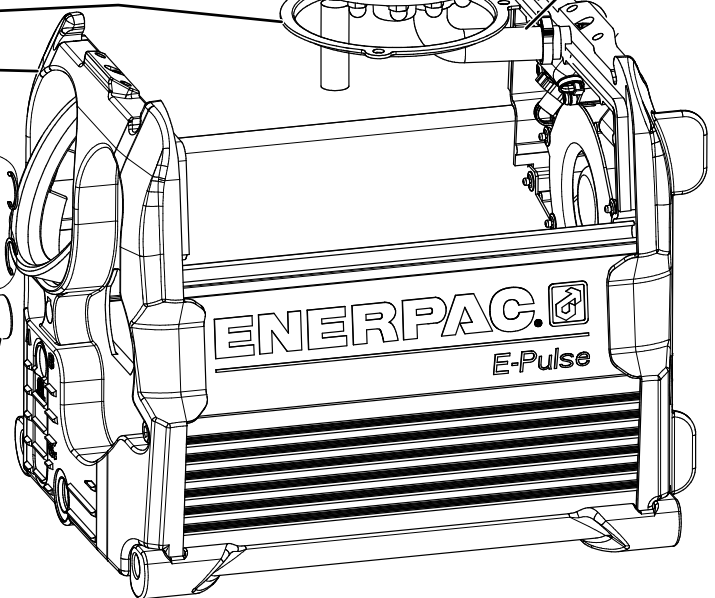

Figure 5, Pump/Motor Assembly
8

Repair Parts List for Figure 5			
Item	Part Number	Qty.	Description
1	B1086066	1	Lockwasher
2	CAE1060108-1A	6	Washer, Flat
3	CBE537028-1A	1	M5 x 0.8 SHCS 60mm Long
4	CBE619028-1A	9	Hex Screw
5	CJ647096	1	Nipple Pipe, 1/2 x 1/4 NPTF, Steel
6	★ ☆ CU421096	2	Ferrule, Ferulok, 0.25 Tube
7	DC6187234	1	Dust Cap Female
8	DC6188020	1	Coupler
9	DC6629020	1	Dust Cap Male
10	DC6763101	1	Counter Weight Plate
11	see Figure 5	1	Motor Replacement Kit
13	DD6793147	1	UARV Knob
15	★ DD7039268	1	Flareless A Port Tube
16	☆ DD7040268	1	Flareless B Port Tube
17	DD7106044	2	Retaining Ring
18	DD7227093	1	Bulkhead Fitting, 1/4" NPT x 0.25"
19	DD7295021	1	UARV Handle Locknut
20	DD7296186	1	UARV Handle Spacer
21	DD7319037	1	Manifold Gasket
22	DD7447037	2	Bulkhead Gasket
23	See Figure 8	1	Valve Assembly
24	See Figure 9	1	Front End Cap Assembly
25	★ ☆ F100093-21	2	Ferulok Nut
26	✚ * S3037	3	Gasket
27	U962148134-2	1	Female Coupler
28	DD7105093	1	Bulkhead Fitting, 1/4" NPT x 0.25"

★ Items are included in Port A Tube Service Kit, DD7039268SR.

☆ Items are included in Port B Tube Service Kit, DD7040268SR.

✚ Items are included in Intake Piston Block Seal Kit, EPPBSK.

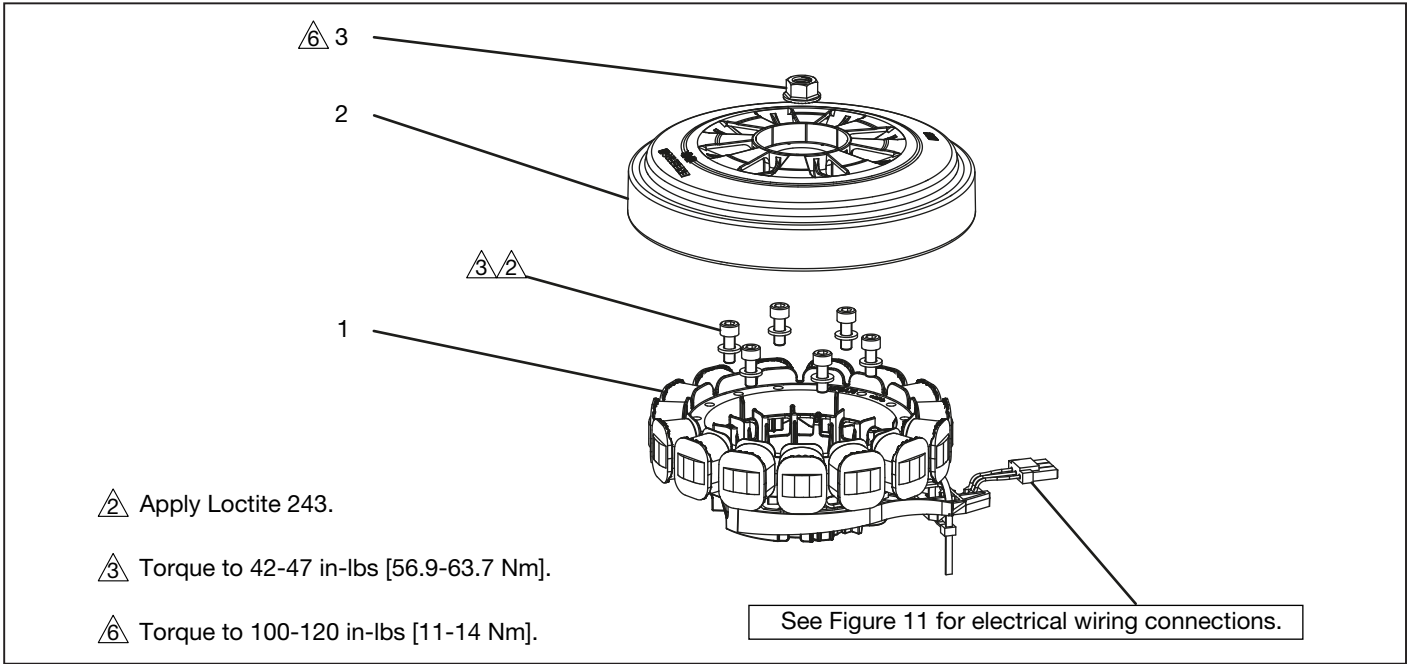

Figure 5A, Motor Replacement Kit

Repair Parts List for Figure 5A			
Item	Part Number	Qty.	Description
1	DD6770259	1	Motor Stator Assembly
2	DD6771257	1	Motor Rotor
3	DD7003021	1	Nut, Flange M10 x 1.25, with Counterbore

Note: Motor Replacement Kit DD6770259K includes all items listed in the table above.

- ⚠ Apply grease to aid assy of housing to manifold.
- ⚡ Torque to 7-9 ft-lbs [9.4-12.2 Nm].
- ⚠ Apply Loctite 2760, and torque to 55-65 in-lbs [6.2-7.3 Nm].
- ⚠ Install flush with top surface, after adding oil.
- ⚠ Orient as shown.

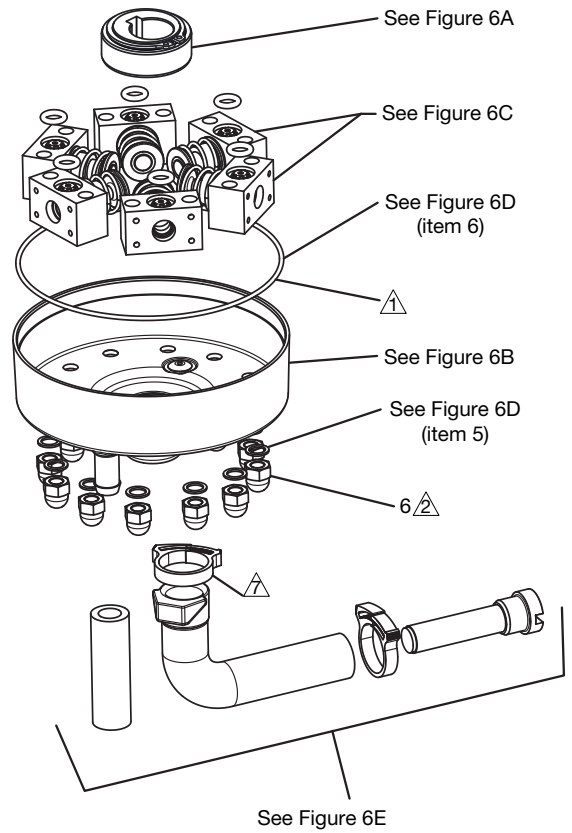
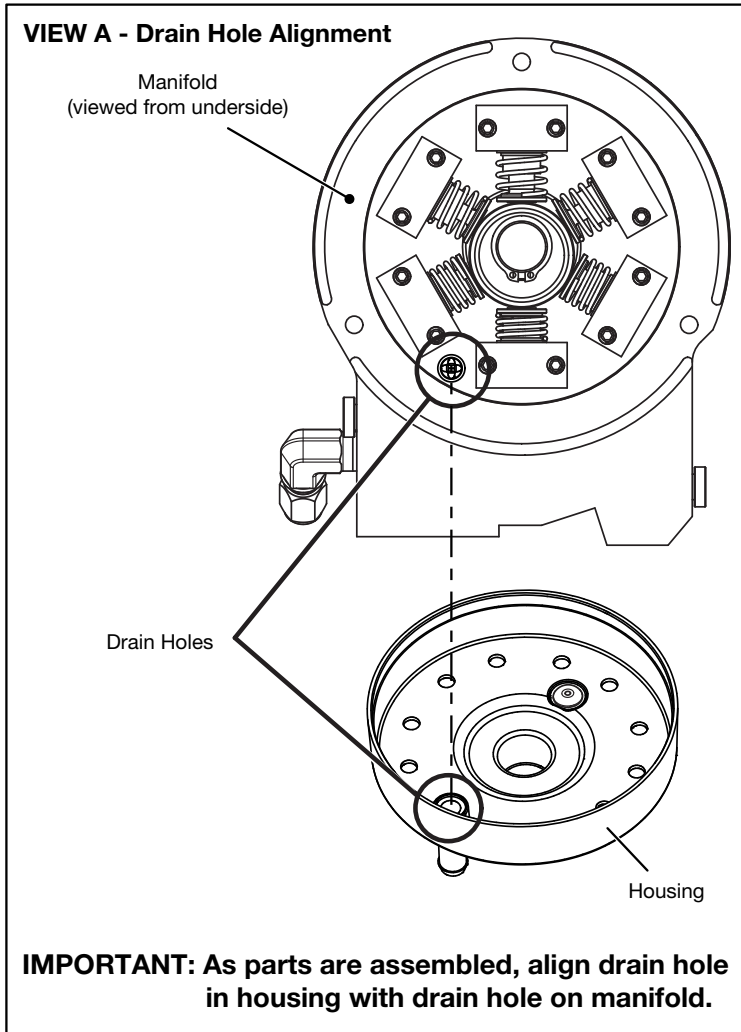
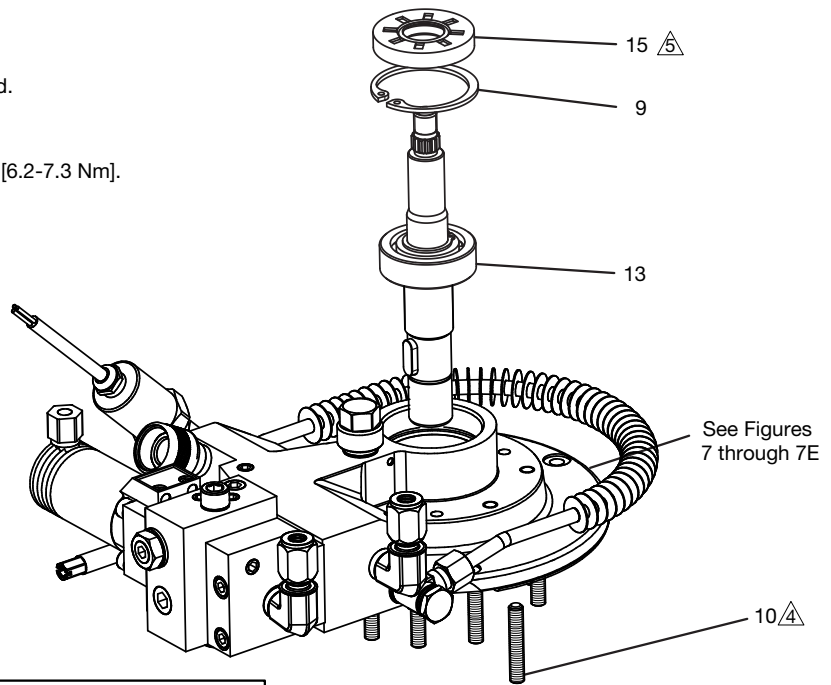
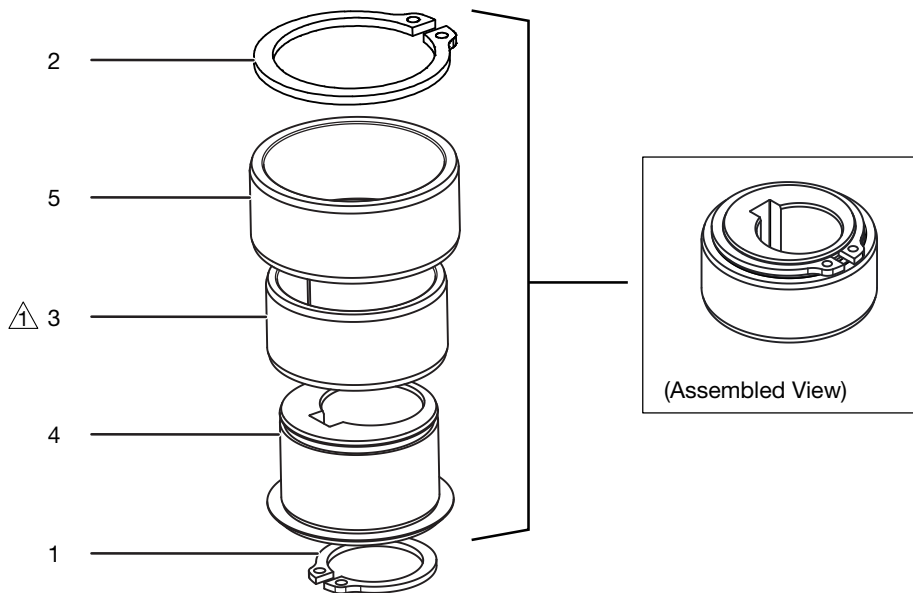

Figure 6, Motor Replacement Kit

Repair Parts List for Figure 6			
Item	Part Number	Qty.	Description
3	B1314503	1	O-Ring-1/4", 7/16", NBR, 70 Duro
6	CAE1060055-1A	12	Acorn Nut M6
9	CCA1042044-1C	1	Wiper Ring
10	CCA627028-5A	12	Screw-Set, Flat, HS, M6 x 1 x 35, 45H, Plain
13	DD7004900	1	Shaft, Sub Assembly
15	DD7008476	1	Seal, Rotary 17 x 42 x 7

Eccentric (items 1-4) is shipped pre-assembled. Parts are shown disassembled for reference purposes only. Item 1 is shipped loose with the eccentric assembly and attaches to the bottom of the motor shaft after the eccentric assembly is put on.



Press fit item 3 onto item 5 with 1100 psi on 10 ton press.

Figure 6A, Eccentric Kit

Repair Parts List for Figure 6A			
Item	Part Number	Qty.	Description
1	CCA1018044-1A	1	Retaining Ring-Ext., 18mm, STL
2	CCA1028044-1A	1	Retaining Ring-Ext., 28mm, STL
3	DD6779350	1	Bearing, Sleeve, 28 x 32 x 15
4	DD7257537	1	Eccentric (3mm Offset)
5	DD7261350	1	Race, Cam

Note: Eccentric Kit DD72575375SR includes all items listed in the table above (pre-assembled).

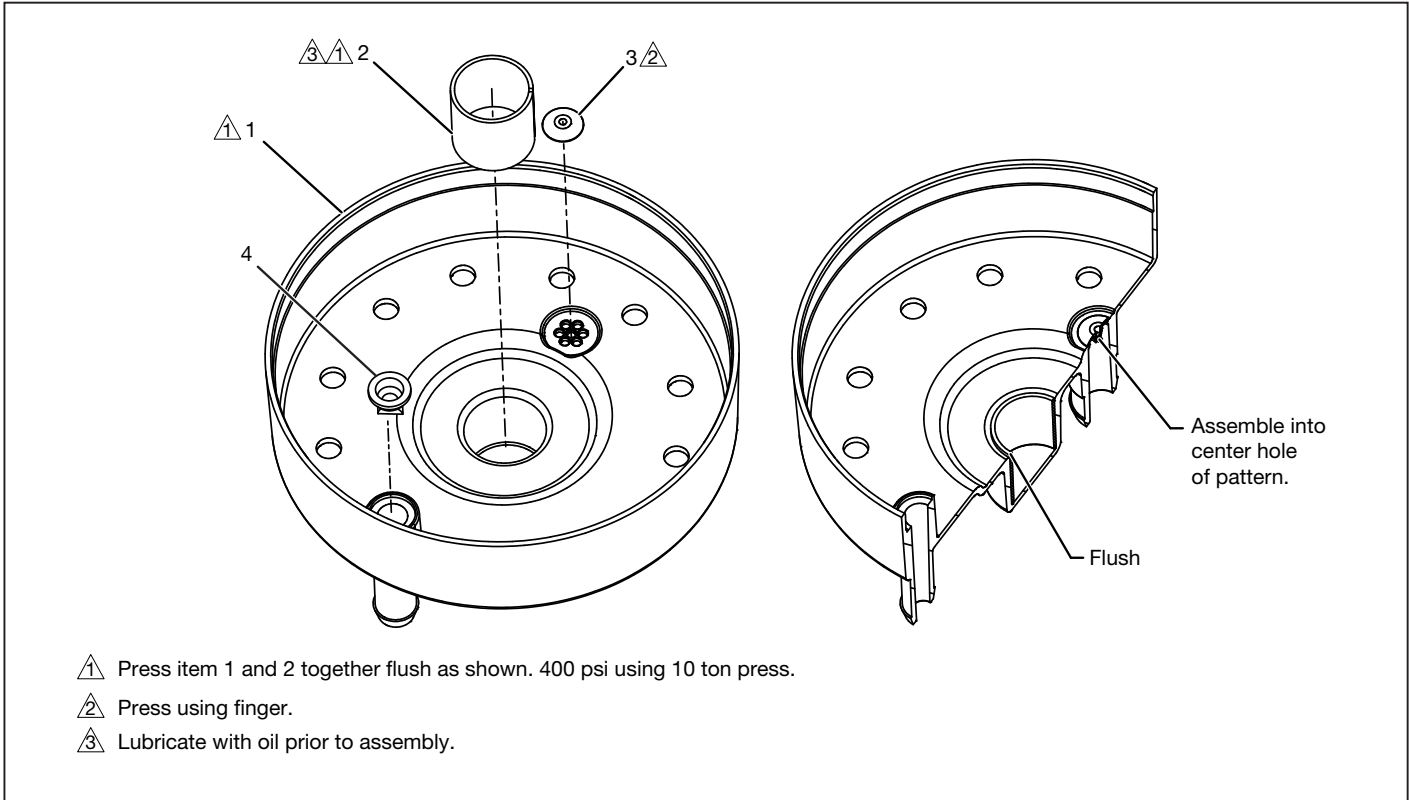
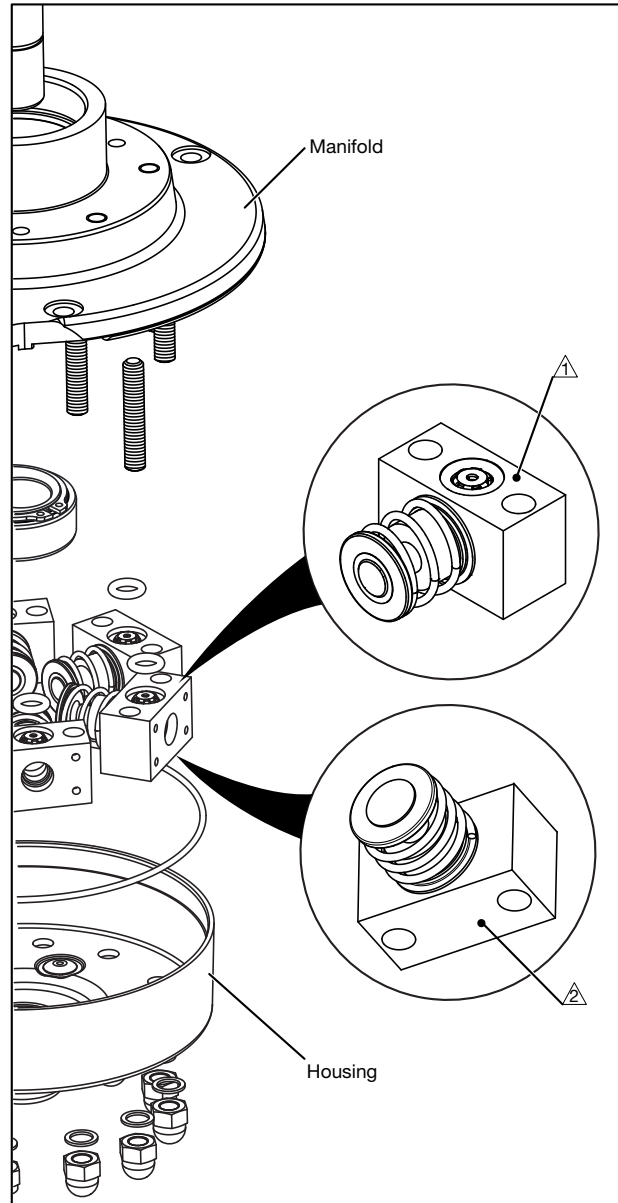
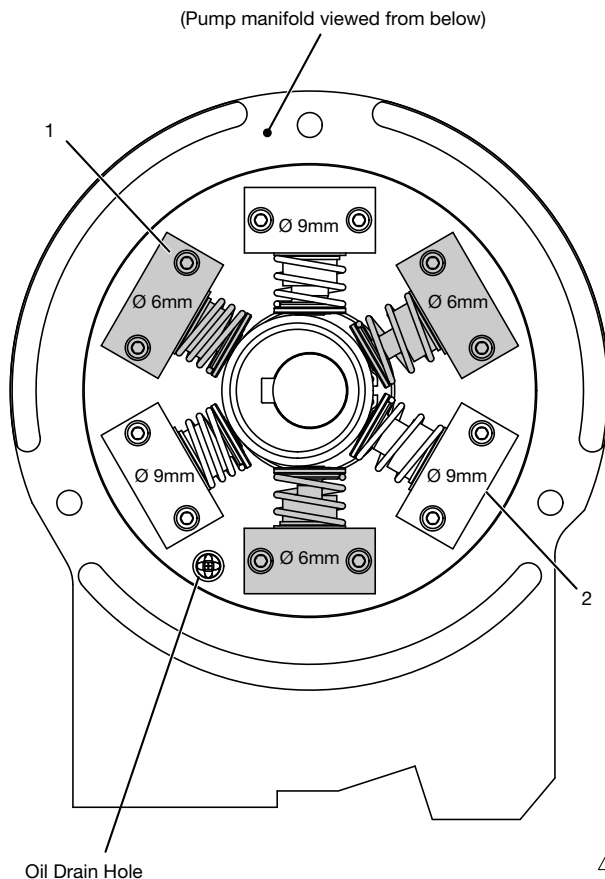
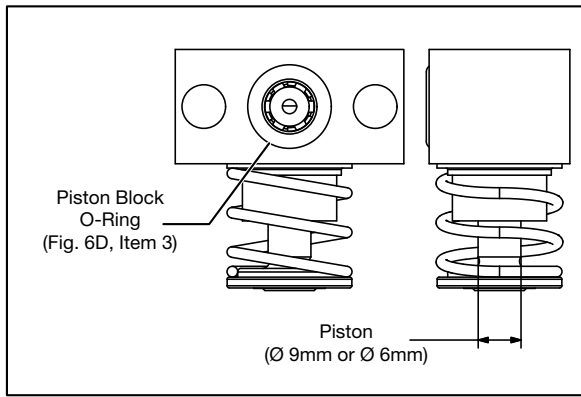

Figure 6B, Pump Housing Kit

Repair Parts List for Figure 6B			
Item	Part Number	Qty.	Description
1	DD6762001	1	Housing, Pump
2	DD6775039	1	Bushing, 18 x 20 x 20, Housing
3	DD6965661	1	Inlet Check Umbrella Valve, Housing
4	DD7603101	1	Valve, Mini, Duckbill

Note: Pump Housing Kit DD7005900SR includes all items listed in the table above.



IMPORTANT:

- ⚠ Side with oil port must face toward manifold.
- ⚠ Flat side must face toward housing.

- Each piston block kit includes 1 piston block and 1 piston block O-Rings (Figure 6D, item 3).
- It is recommended that new O-Rings be installed on ALL piston blocks, even if only some of the piston blocks are being replaced.
- A complete set of O-Rings and gaskets is provided in the piston block seal kit (order separately - See Figure 6D).
- Refer to Figures 6, 6A, 6B and 6D for torque values and additional assembly instructions.

Figure 6C, Piston Block Assembly Kits

Repair Parts List for Figure 6C			
Item	Part Number	Qty.	Description
1	DD7230900SR	3	Piston Block, \varnothing 6mm
2	DD7231900SR	3	Piston Block, \varnothing 9mm

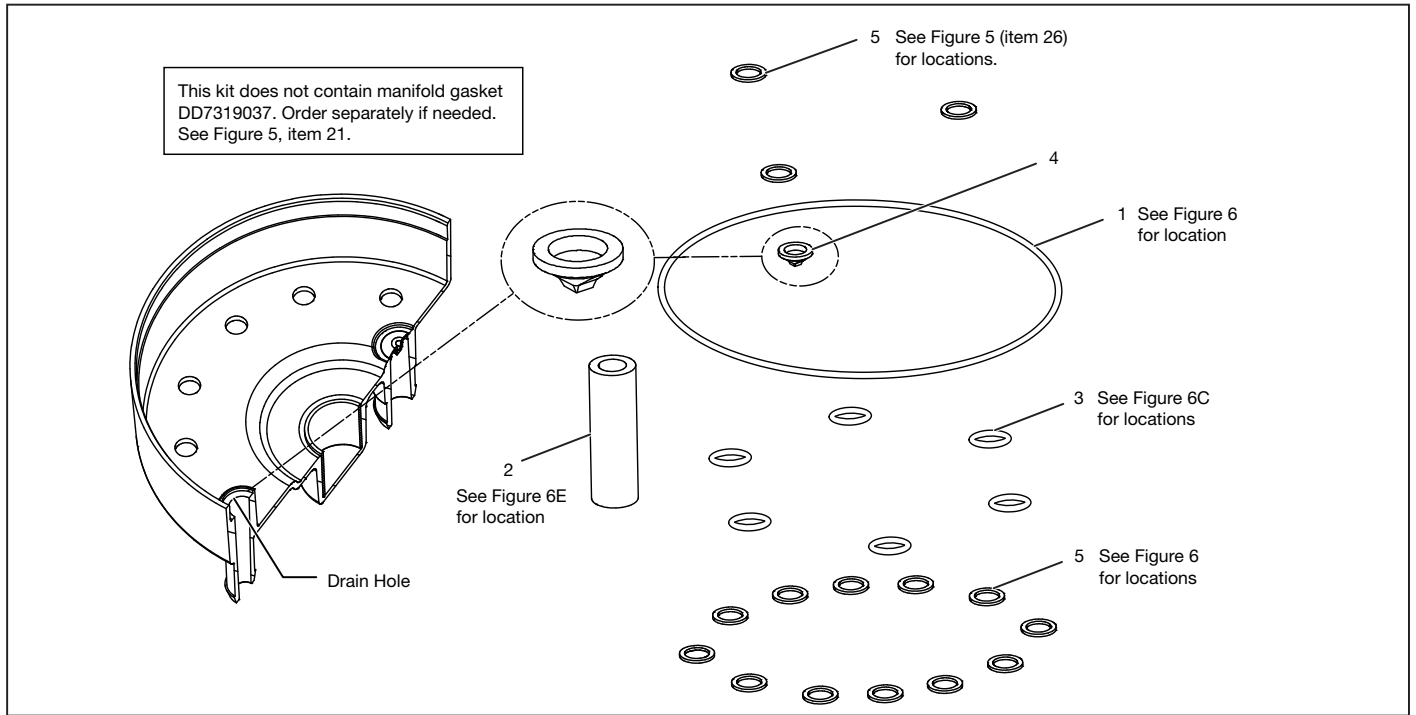

Figure 6D, Piston Block Seal Kit

Repair Parts List for Figure 6D			
Item	Part Number	Qty.	Description
1	B1400503	1	O-Ring 4-1/4", 4-3/8", 1/16", NBR, 70 Duro
2	DD7002646	1	Hose Rubber, 9.52 x 15.88 x 50L
3	DD7616903	6	O-Ring, Piston Block, Metric, 8 x 2, NBR, 90 Duro
4	DD7603101	1	Valve Mini, Cross-Slit
5	S3037	12	Gasket

Note: Piston Block Seal Kit EPPBSK includes all items listed in the table above.

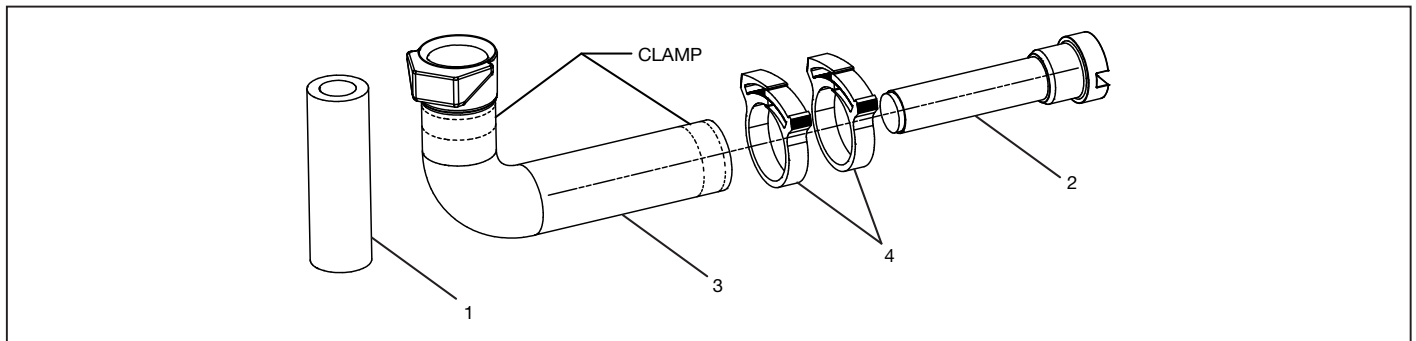

Figure 6E, Intake Suction Filter Kit

Repair Parts List for Figure 6E			
Item	Part Number	Qty.	Description
1	DD7002646	1	Hose, Rubber, 9.52 x 15.88 x 50L
2	DD7176118	1	Filter, In Line
3	DD7177268	1	Tube, Inlet Filter
4	DD7222299	2	Clamp, Inlet Filter

Note: Intake Suction Filter Kit DD7176118K includes all items listed in the table above.

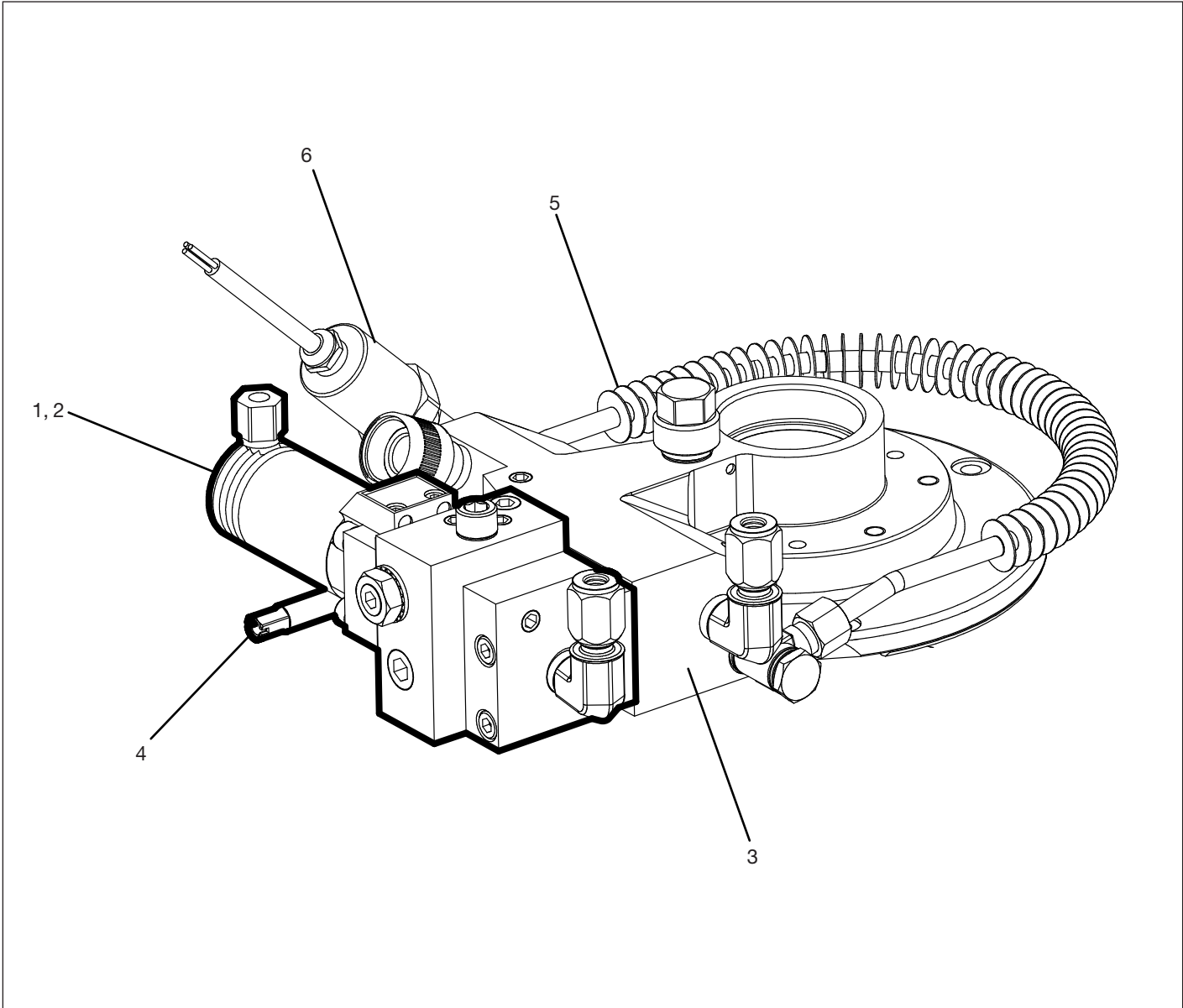

Figure 7, Major Components, Control Valve and Pump

Repair Parts List for Figure 7			
Item	Part Number	Qty.	Description
1, 2	see Figure 7A and 7B	1	Control Valve and Mounting
3	see Figure 7D	1	Direct Drive Pump
4	see Figure 7E	1	User Adjustable Relief Valve
5	see Figure 7C	1	Heat Exchanger Assembly
6	see Figure 7C	1	Pressure Transducer

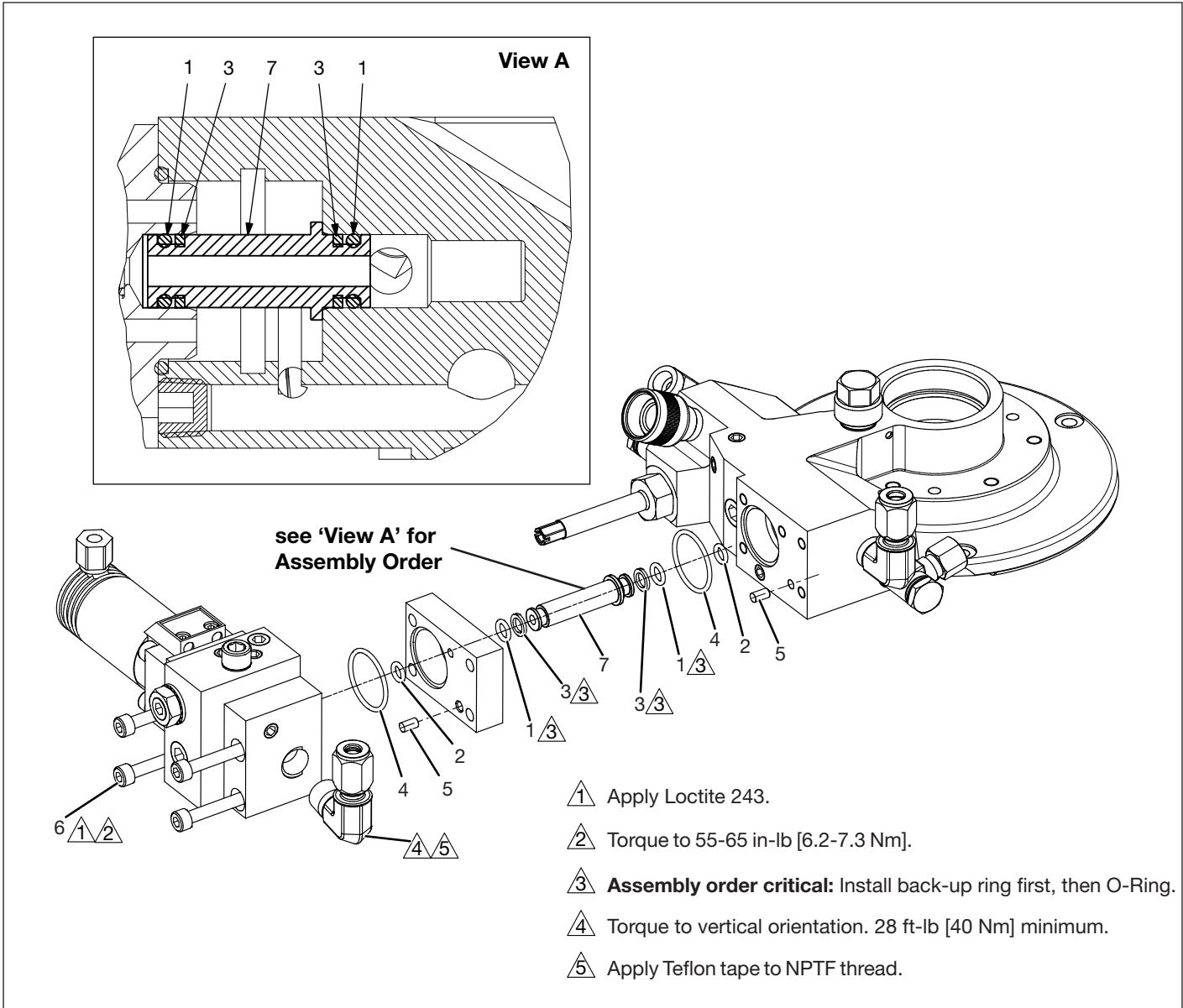
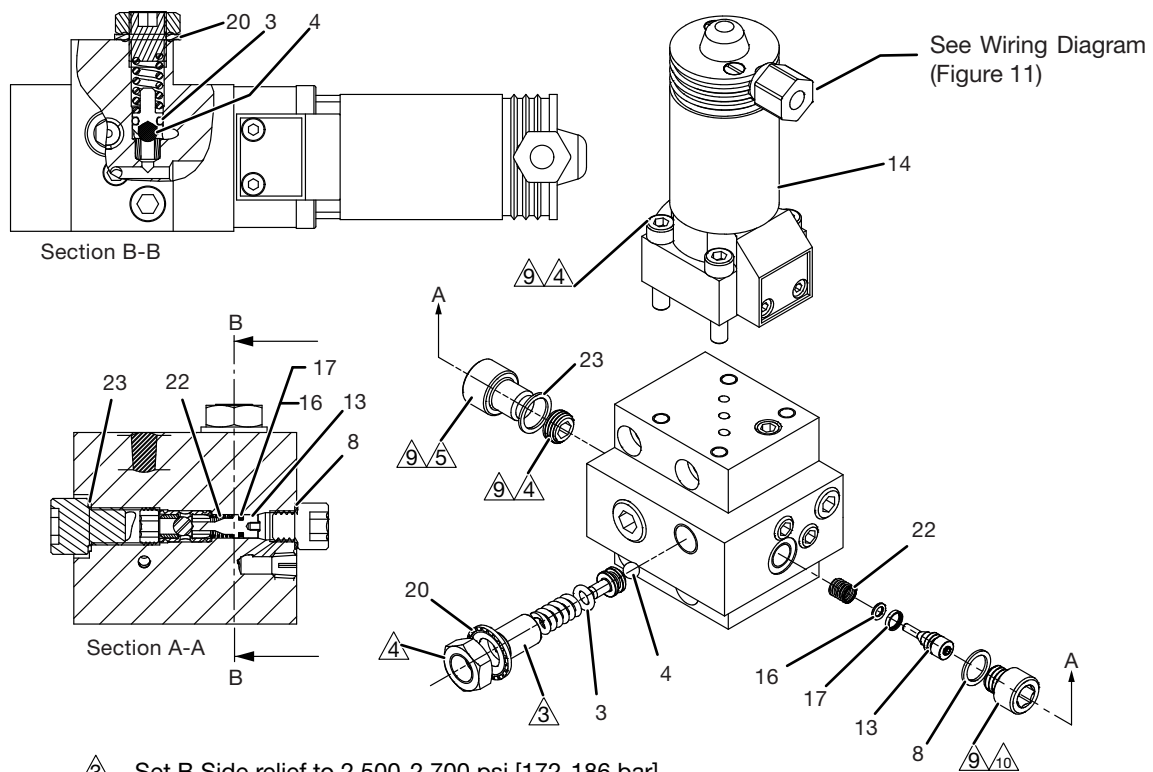

Figure 7A, Control Valve Mounting Hardware and Hydraulic Connections

Repair Parts List for Figure 7A				
Item		Part Number	Qty.	Description
1	I	B1005503	2	O-ring 1/4" x 3/8" x 1/16"
2	I	B1009803	2	O-ring 7/32" x 11/32" x 1/16"
3	I	B1010564	2	Back-up Ring
4	I	B1227503	2	O-ring 15/16" x 1-1/16" x 1/16"
5	I	CAA411016-2B	2	4mm x 8mm Dowel Pin
6	I	CCA535028-1A	4	Screw, Hex, M5
7	I	DD7033268	1	Tube, Connector, Spacer

I Items are included in Torque Wrench Valve Replacement Kit, EP5TWVSK.



- ③ Set B Side relief to 2,500-2,700 psi [172-186 bar].
- ④ Torque to 55-65 ft-lbs [6.2-7.3 Nm].
- ⑤ Torque to 20-22 ft-lbs [27.1-29.8 Nm].
- ⑨ Apply Loctite 243.
- ⑩ Torque to 90-100 ft-lbs [10.17-11.30 Nm].

Figure 7B, Valve Assembly

Repair Parts List for Figure 7B				
Item	Part Number	Qty.	Description	
3	❖ B1003503	1	O-ring	
4	❖ B1005016	1	Ball 3/16"	
8	❖ C846037	1	Copper Gasket	
13	❖ DD4790051	1	Piston, B-Side Pilot	
14	DD5655660SR	1	Valve 3-Way 2-Position	
16	❖ DD6330141	1	Piston O-ring	
17	❖ DD6331141	1	Piston Slipper	
20	❖ DD7232314	1	Zinc Plated Steel Sealing Washer	
22	❖ DD7363110	1	Spring	
23	❖ P20037	1	Gasket, Valve Plug	

❖ Items are included in 4-2 Torque Wrench Valve Rebuild Kit And Hawe Replacement Kit, EP5TWSR.

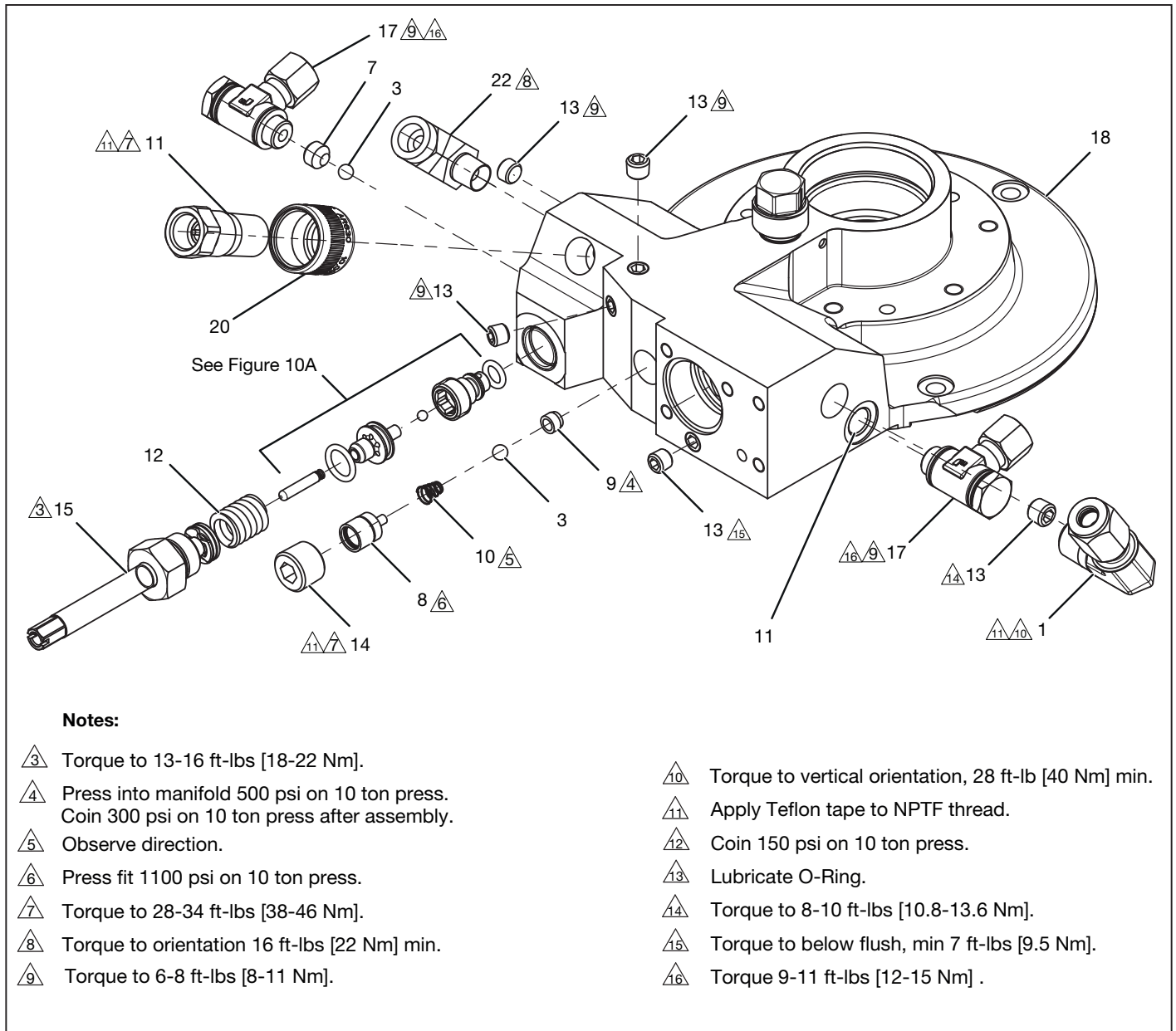

Figure 7C, Direct Drive Pump Assembly

Repair Parts List for Figure 7C							
Item	Part Number	Qty.	Description	Item	Part Number	Qty.	Description
1	A8033096	1	Elbow Fitting 0.25 NPTF x 0.25 Flareless	13	DC6792245	5	PTF-SAE Flush Plug 0.062
3	B1005016	2	Ball, 3/16 Dia.	14	DC6793245	1	PTF-SAE Flush Plug 0.125
7	BF3104027A	1	Retaining Ring	15	DD6778900	1	Plug Asm. UARV
8	BSS5357D	1	Seat Piston Upper	17	DD6995094	2	Fitting, Banjo, BSPP G1/8 x 6
9	BSS5358D	1	Seat Piston Lower	18	DD7052900	1	Direct Drive Pump, DMPE
10	BSS5809D	1	Conical Spring	20	M49489	1	Collar
11	CF778900	1	Ram Coupler Purch Comp.	22	Y714291	1	Elbow
12	DA3282110	1	Spring-Comp., 320 lbs/in				

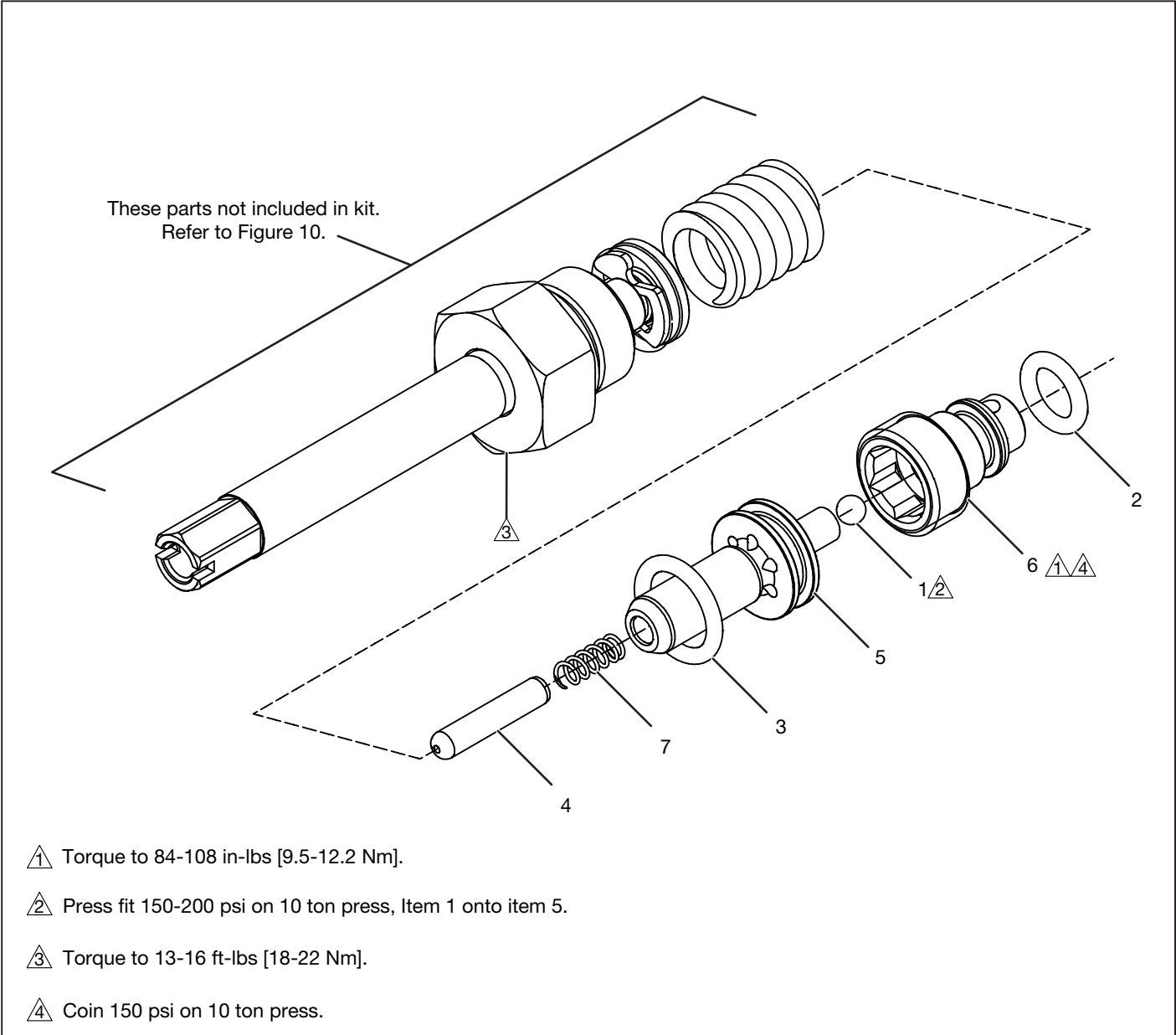

Figure 7D, Rebuild Kit, User-Adjustable Relief Valve (UARV)

Repair Parts List for Figure 7D			
Item	Part Number	Qty.	Description
1	B1003016	1	Ball, 0.125 Dia.
2	B1010803	1	O-Ring-1/4", 3/8", 1/16", Disogrin, 92 Duro
3	B1012203	1	O-Ring-3/8", 1/2", 1/16", Viton, 90 Duro
4	BA0210059	1	Dowel Pin 1/8" x 5/8" Long
5	DD6780013	1	Ball Guide
6	DD7234290	1	Ball Seat
7	PA27110	1	Spring-Comp., 8.30 lbs/in

Note: UARV Rebuild Kit DD7234290K includes all items listed in the table above.

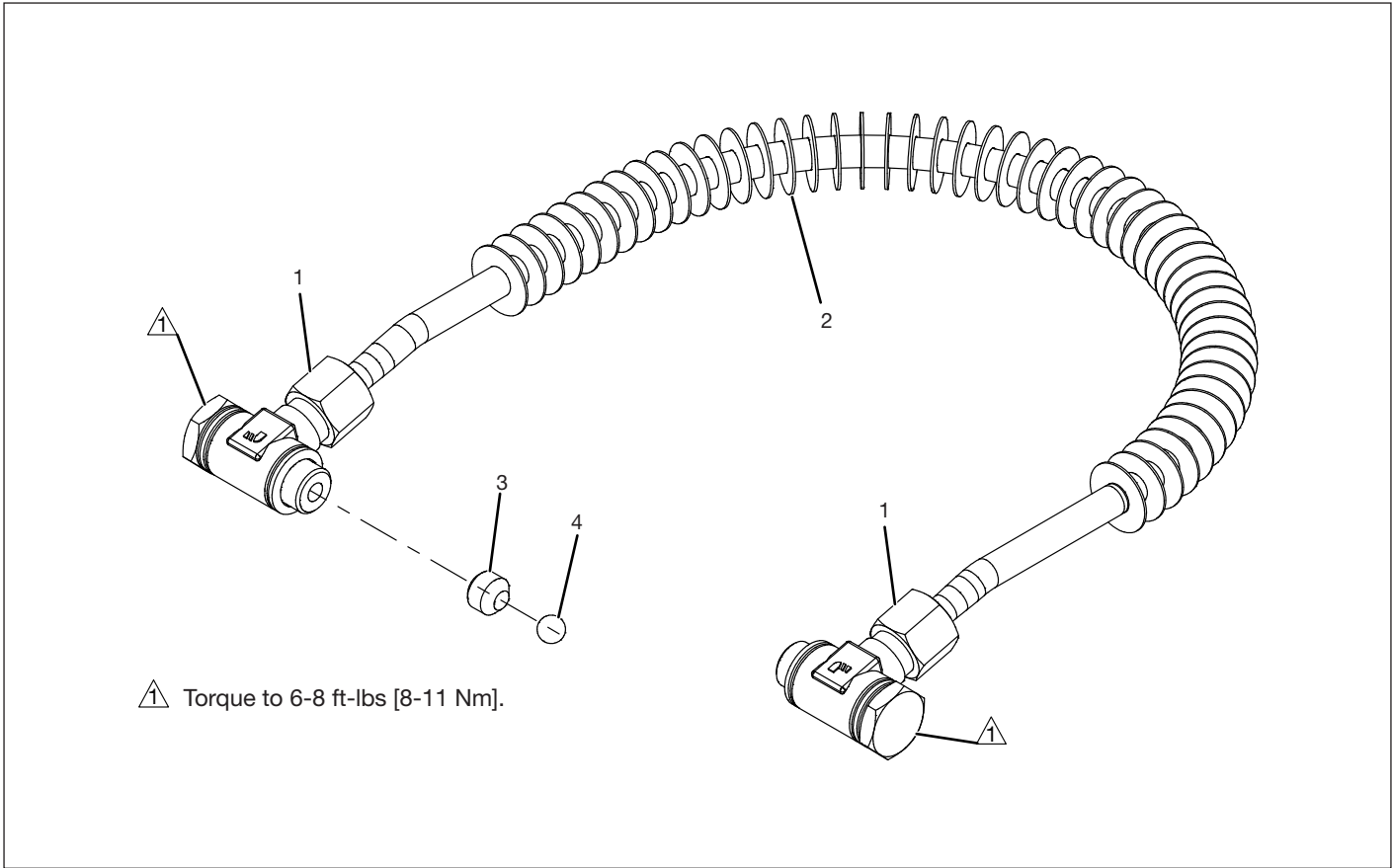



Figure 7E, Heat Exchanger Assembly

Repair Parts List for Figure 7E			
Item	Part Number	Qty.	Description
1	DD6995094	2	Banjo Fitting
2	DD26999471	1	Heat Exchange Fin Tube
3	BF3104027	1	Set Screw
4	B1005016	1	Ball 3/16"

Note: Heat Exchanger Kit DD6999471SR includes all items listed in the table above.

 Torque to 60-70 in-lb [6.8-7.9 Nm].

 Torque to 106-133 in-lb [12-15 Nm].

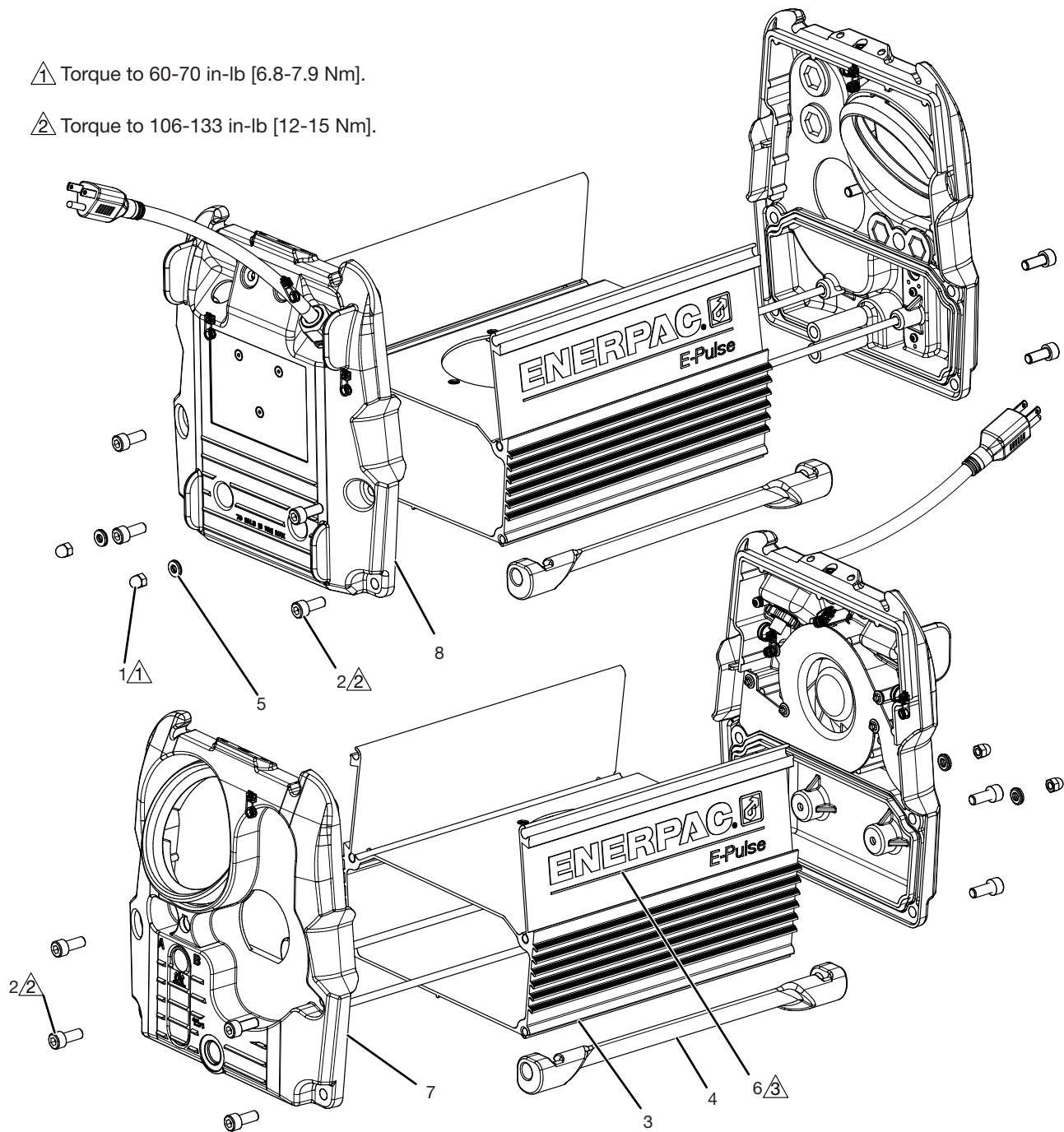

Figure 8, Reservoir Assembly

Repair Parts List for Figure 11

Item	Part Number	Qty.	Description	Item	Part Number	Qty.	Description
1	CAE1060055-1A	2	Acorn Nut	5	** DD7164108	2	Rubber Sealing Washer
2	CBE821028-1A	8	Hex Screw	6	* DD7290026	2	Decal
3	* DD6788025-P03	1	1 Gallon Reservoir	7	see Figure 9	1	Front End Cap Assembly
4	DD6795870	2	Rubber Foot	8	see Figure 10	1	Rear End Cap Assembly

* Items are included in Reservoir Sealing Kit, EPRSK.

* Items are included in Reservoir Replacement Kit, DD6788025SR.

- ⚠ 1 Apply Loctite 2760.
- ⚠ 2 Torque to 8-10 in-lb [0.9-1.1 Nm].
- ⚠ 3 Remove adhesive backing before assembly.
- ⚠ 4 Install to full depth.
- ⚠ 5 Torque to 25-30 in-lb [2.8-3.4 Nm].

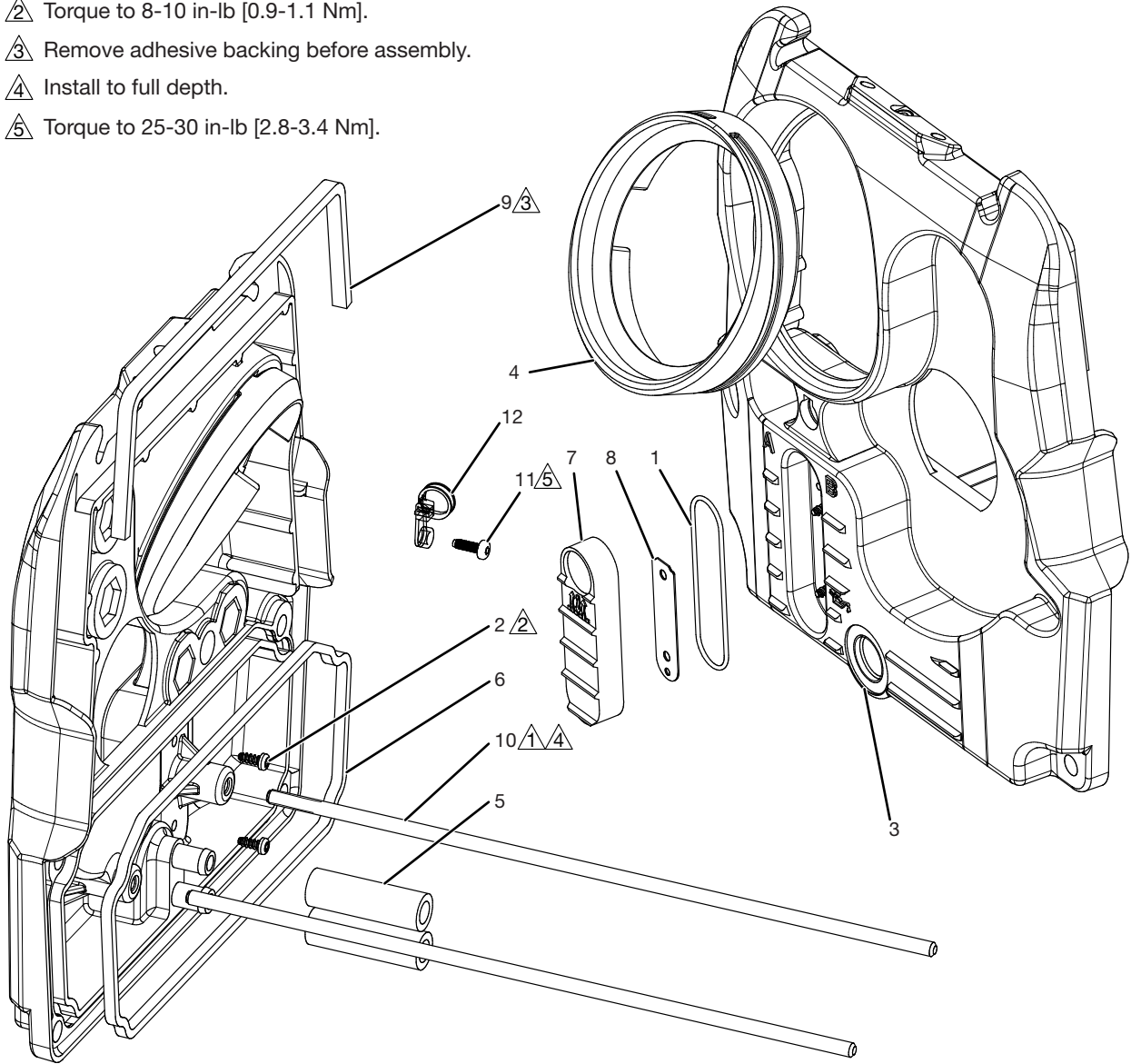

Figure 9, Front End Cap Assembly

Repair Parts List for Figure 9

Item	Part Number	Qty.	Description	Item	Part Number	Qty.	Description
1	❖ B1240503	1	O-ring	7	❖ DD7021223	1	Sight Gauge
2	❖ DD3883028	2	Screw	8	❖ DD7022225	1	Sight Gauge Insert
3	DD6784020	1	Front End Cap	9	* DD7030037	1	Gasket Tape
4	DD6796808	1	Gauge Grommet	10	DD7107305	2	Threaded Rod
5	DD7002646	2	Rubber Hose	11	DD7238001	1	Screw
6	* * DD70170371	1	Endcap Gasket	12	DD7331217	1	Cable Tie

- ❖ Items are included in Sight Glass Kit, DD7021223K.
- * Items are included in Reservoir Sealing Kit, EPRSK.
- * Items are included in Reservoir Replacement Kit, DD6788025SR.
- * Items are included in Water Ingress Seal Service Kit, EPWISK.

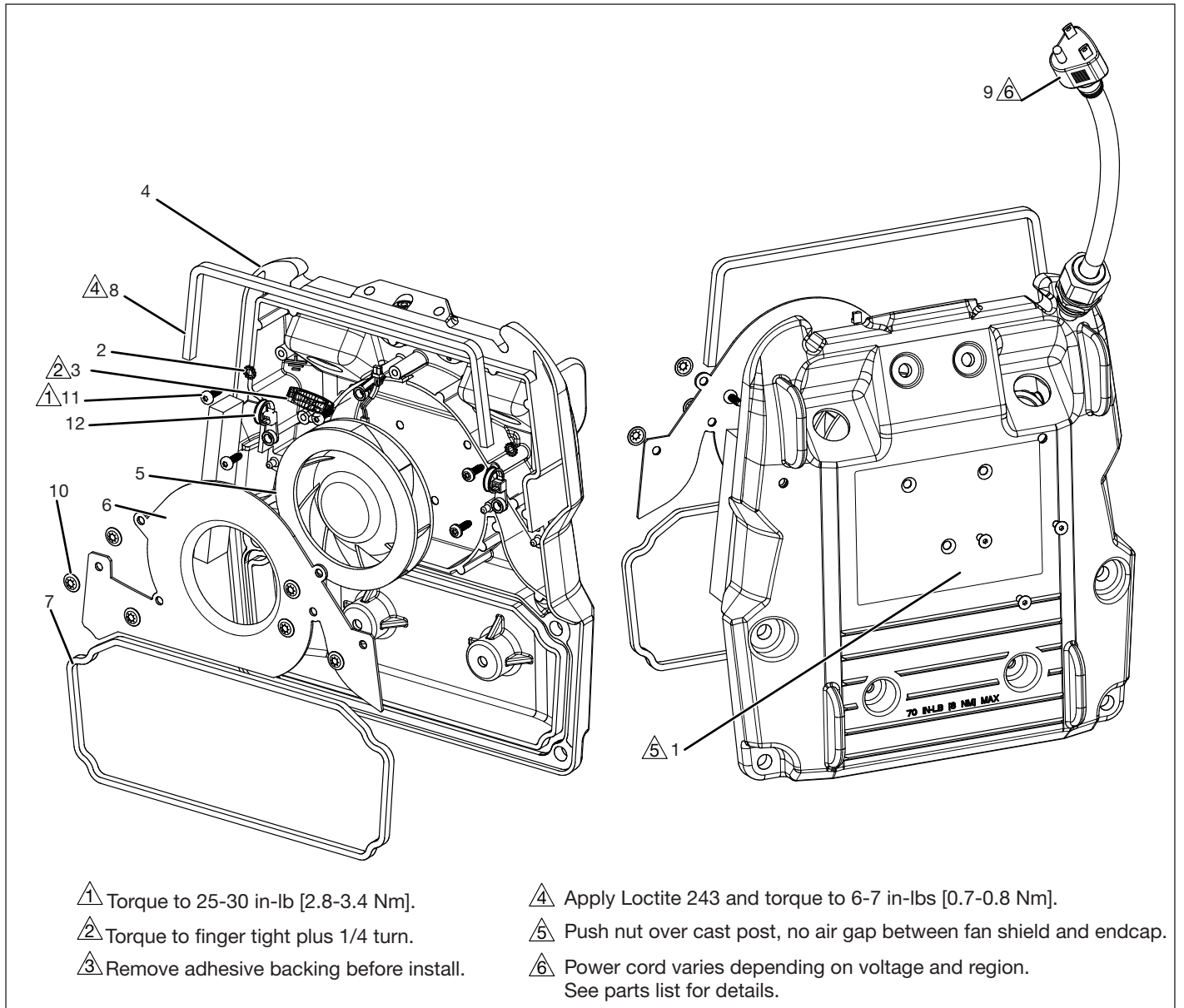

Figure 10, Rear End Cap Assembly

Repair Parts List for Figure 10							
Item	Part Number	Qty.	Description	Item	Part Number	Qty.	Description
1	* CBA413028-1B	3	Hex Screw Flathead	8	* DD7030037	1	Gasket Tape
2	CCE1040108-7A	2	Lock Washer	9	see Figure 10A	1	Power Cord Replacement Kit
3	* □+ DC9538021	1	Locking Nut	10	* DD7165021	6	Nut
4	DD6786020	1	Rear End Cap	11	DD7328001	5	Screw
5	* DD6978470	1	Fan	12	DD7331217	2	Cable Tie
6	* DD6979298	1	Fan Shield				
7	* ❖ * DD7017037	1	Endcap Gasket				

- * Items are included in Heat Exchanger Fan Kit, DD6978470K.
- * Items are included in Reservoir Replacement Kit, DD6788025SR.
- ❖ Items are included in Water Ingress Seal Service Kit, EPWISK.
- * Items are included in Reservoir Sealing Kit, EPRSK.

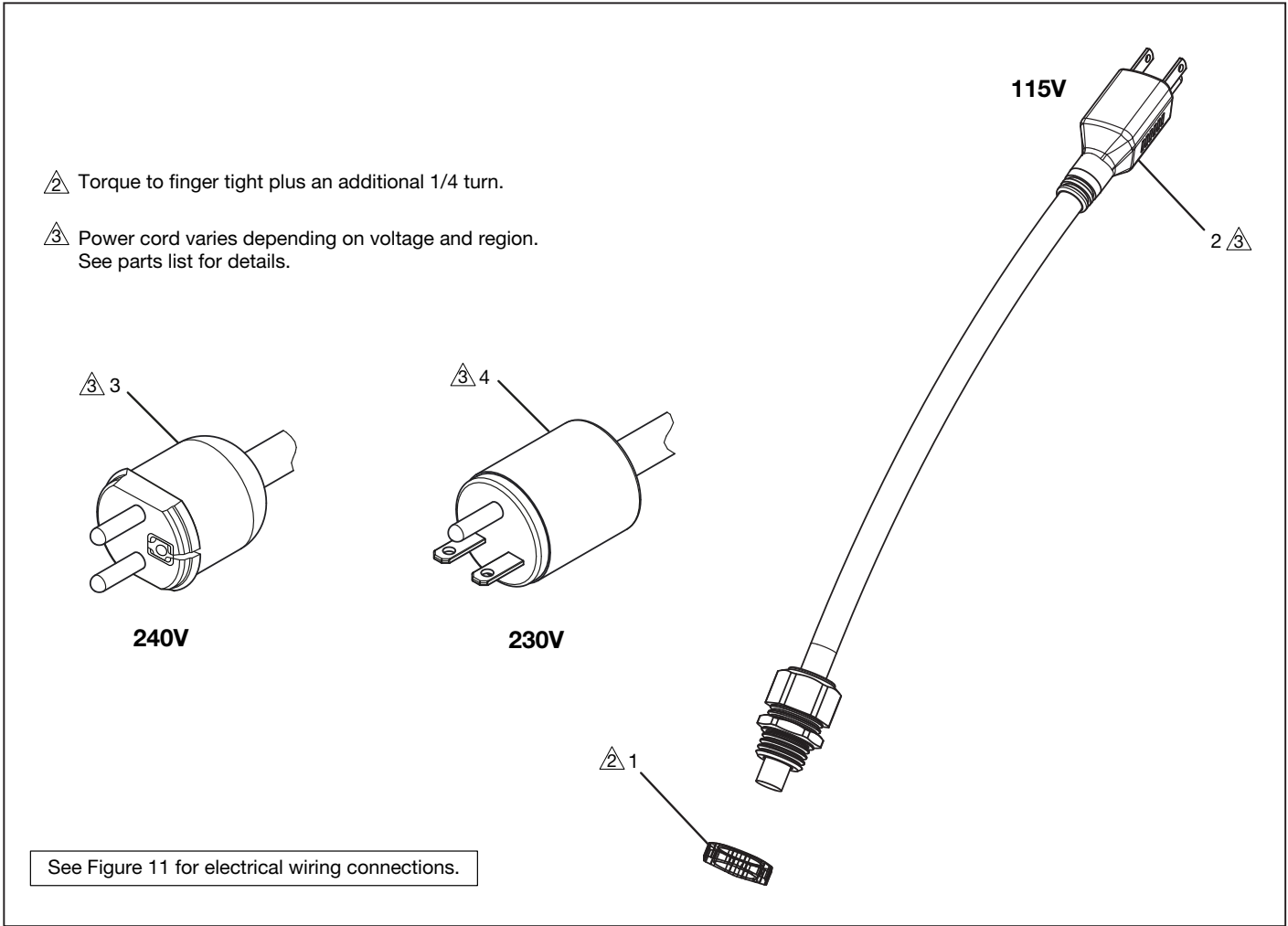

Figure 10A, Power Cord Replacement Kit

Repair Parts List for Figure 10A			
Item	Part Number	Qty.	Description
1	DC9538021	1	Locking Nut 20mm
2	DD7044960SR	1	Power Cord, 115 VAC, 50/60 Hz, NEMA 5-15 (EP3504TB and EP3504TB-M)
3	DD7045960SR	1	Power Cord, 208/230 VAC, 50/60 Hz, NEMA 6-15 (EP3504TI and EP3504TI-M)
4	DD7046960SR	1	Power Cord, 208/240 VAC, 50/60 Hz, CEE 7/7 EHUK (EP3504TE and EP3504TE-M)

Note: Item 1 NOT included in power cord kits. Order separately.

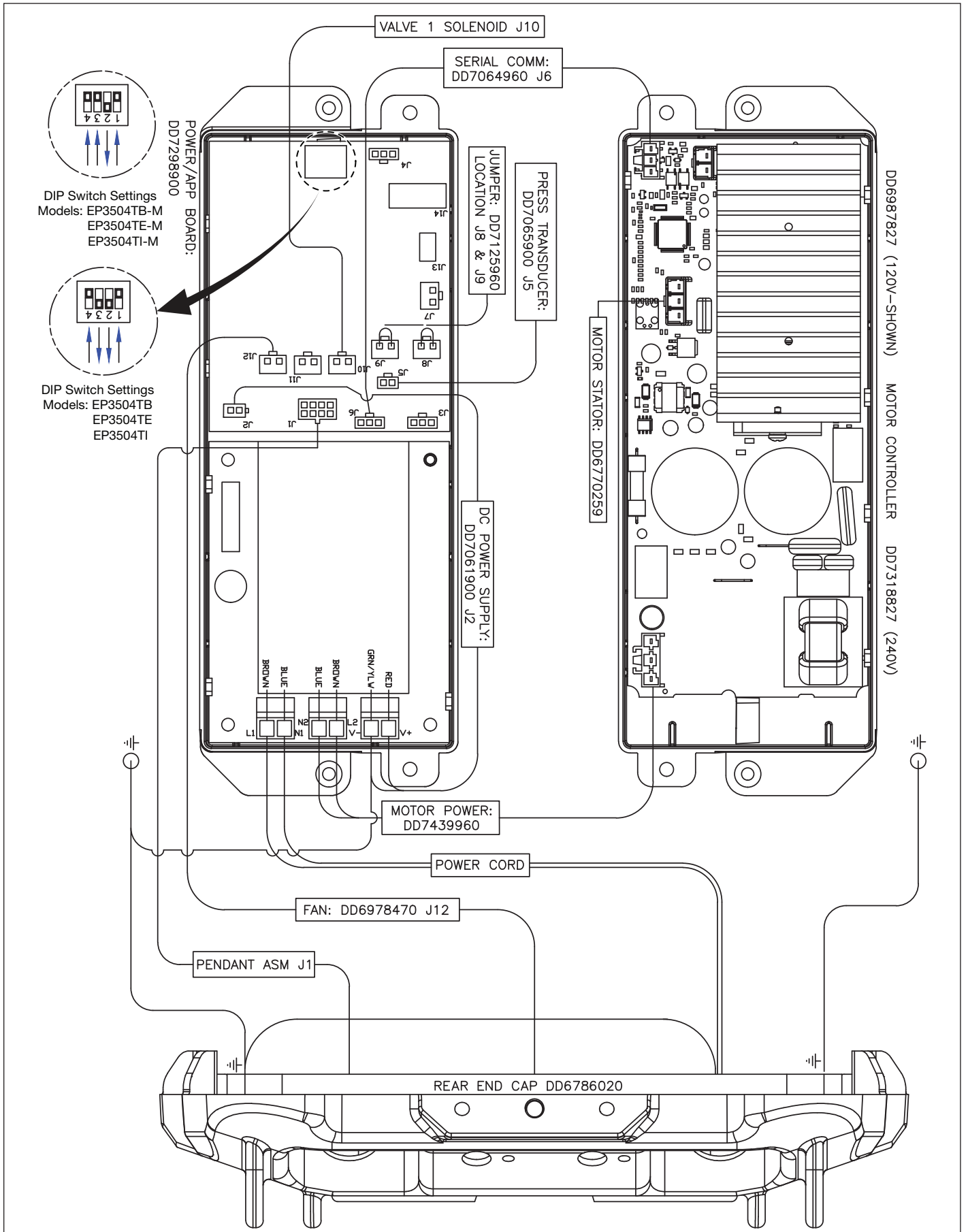

Figure 11, Electrical Block Wiring Diagram

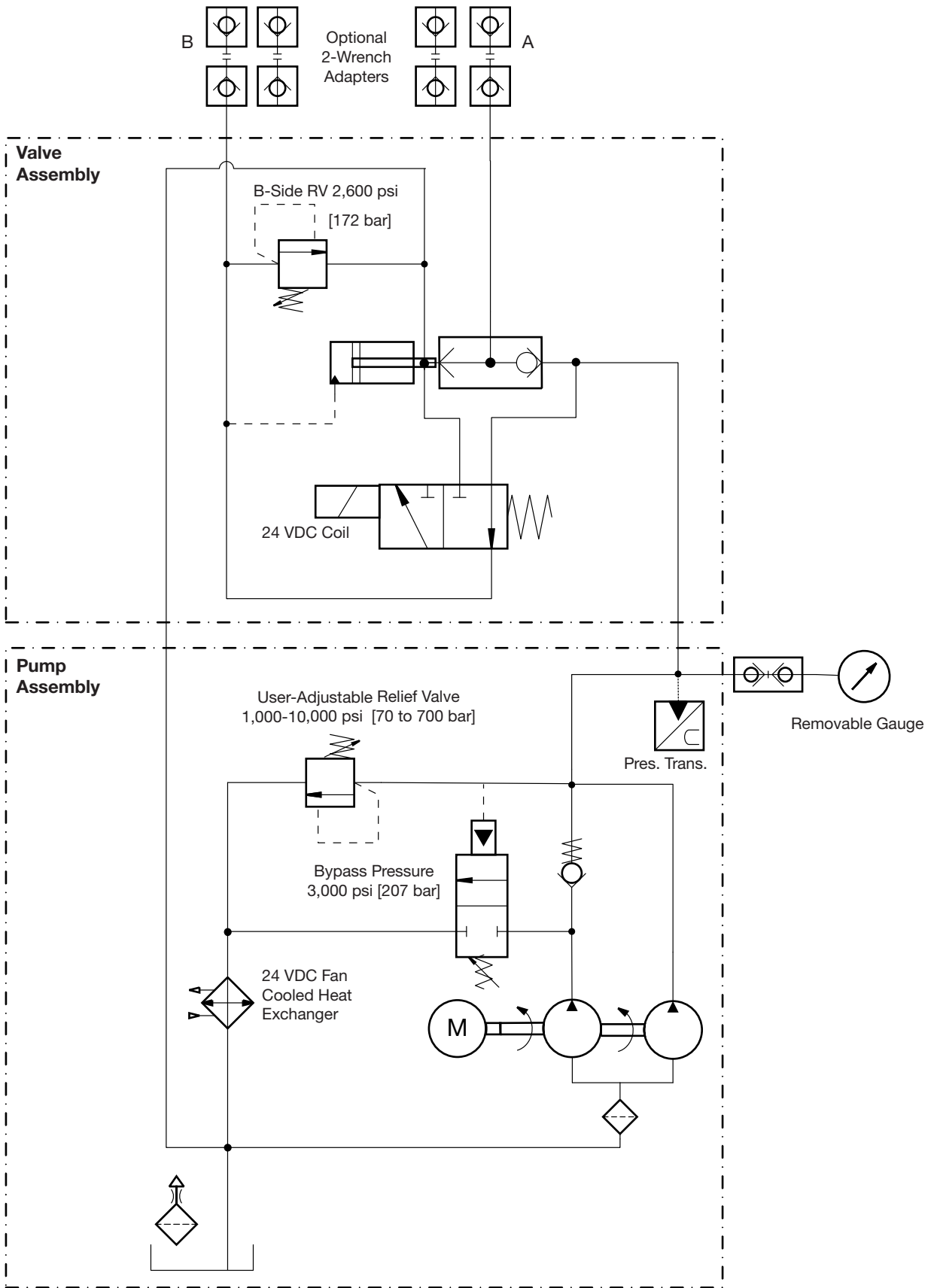
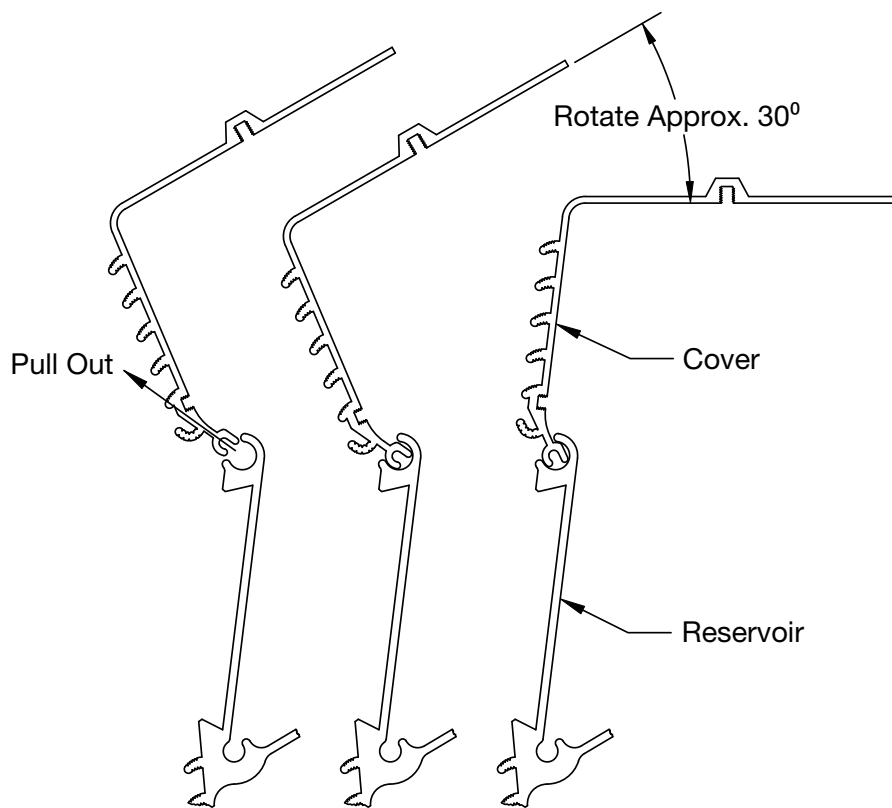
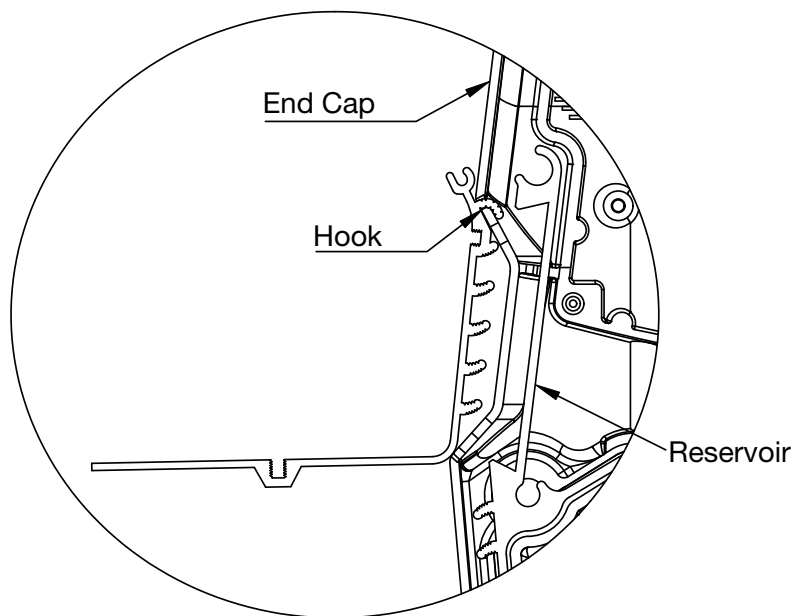

Figure 12, Hydraulic Schematic



To Remove/Install Cover



Removal/installation instructions:

1. Remove 2 pump handle screws and washers.
2. Remove pump handle.
3. Open cover and remove wire connections.
4. Rotate cover approximately 30° from closed position.
5. Pull cover out as shown.
6. Reverse directions for installation. Refer to wiring diagram (Figure 13) and electrical subassembly diagrams (Figures 3 and 4) for wiring and torques.
7. Torque handle screws to 42-47 in-lbs [4.7-5.3 Nm].

Figure 13, Pump Cover Removal/Installation Instructions

Notes:

Notes:

ENERPAC 

www.enerpac.com