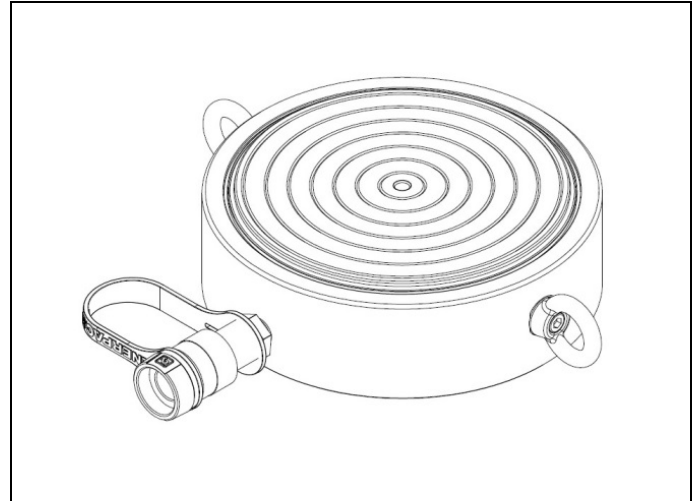



Table of Contents

1.0 IMPORTANT RECEIVING INSTRUCTIONS	1
2.0 SAFETY	1
3.0 CONFORMANCE TO NATIONAL AND INTERNATIONAL STANDARDS	3
4.0 PRODUCT DESCRIPTION	3
5.0 LIFTING THE CYLINDER.....	3
6.0 SETUP	4
7.0 AVOIDING SIDE LOAD.....	5
8.0 OPERATION	5
9.0 INSPECTION, MAINTENANCE & STORAGE	5
10.0 TROUBLESHOOTING	6
11.0 PRODUCT DATA.....	7



1.0 IMPORTANT RECEIVING INSTRUCTIONS

Visually inspect all components for shipping damage. Shipping damage is not covered by warranty. If shipping damage is found, notify carrier at once. The carrier is responsible for all repair and replacement costs resulting from damage in shipment.

2.0 SAFETY

2.1 Introduction

Read all instructions carefully. Follow all recommended safety precautions to avoid personal injury as well as damage to the product and/or damage to other property. Enerpac cannot be responsible for any damage or injury from unsafe use, lack of maintenance or incorrect operation. Do not remove warning labels, tags, or decals. In the event any questions or concerns arise, contact Enerpac or a local Enerpac distributor for clarification.

If you have never been trained on high-pressure hydraulic safety, consult your distributor or service center for information about an Enerpac Hydraulic Safety Course.

This manual follows a system of safety alert symbols, signal words and safety messages to warn the user of specific hazards. Failure to comply with these warnings could result in death or serious personal injury, as well as damage to the equipment or other property.

 The **Safety Alert Symbol** appears throughout this manual. It is used to alert you to potential physical injury hazards. Pay close attention to Safety Alert Symbols and obey all safety messages that follow this symbol to avoid the possibility of death or serious personal injury.

Safety Alert Symbols are used in conjunction with certain Signal Words that call attention to safety messages or property damage messages and designate a degree or level of hazard seriousness. The Signal Words used in this manual are WARNING, CAUTION and NOTICE.



Indicates a hazardous situation that, if not avoided, **could** result in death or serious personal injury.



Indicates a hazardous situation that, if not avoided, **could** result in minor or moderate personal injury.



Indicates information considered important, but not hazard related (e.g. messages relating to property damage). Please note that the Safety Alert Symbol will **not** be used with this signal word.

2.2 Hydraulic Cylinder Safety Precautions (CUSP-Series)



Failure to observe and comply with the following precautions could result in death or serious personal injury. Property damage could also occur.

- Read and completely understand the safety precautions and instructions in this manual before operating the cylinder or preparing it for use. Always follow all safety precautions and instructions, including those that are contained within the procedures of this manual.
- Operating procedures will vary, depending on the system arrangement. Always read, follow and completely understand all manufacturer's instructions when operating pumps, valves and all other devices used with the cylinders. Follow all safety precautions contained in the manufacturer's manuals.

- Always wear appropriate personal protective equipment (P.P.E.) when operating hydraulic equipment. Be sure to wear eye protection, work gloves and protective clothing. Use of additional P.P.E. safety items such as dust mask, non-skid safety shoes, hard hat, and hearing protection (used as appropriate for the conditions) will reduce the chance of personal injuries. The use of these items may also be required by local regulations or laws.
- Do not handle pressurized hoses. Escaping oil under pressure can penetrate the skin. If oil is injected under the skin, see a doctor immediately.
- Do not pressurize disconnected couplers.
- Use hydraulic cylinders only in a coupled system.
- Do not remove or disable the pump relief valve.
- The system operating pressure must not exceed the pressure rating of the lowest rated component in the system.
- Install pressure gauge(s) in the system to monitor operating pressure. It is your window to see what is happening in the system.
- Never set a relief valve to a higher pressure than the maximum rated pressure of the pump and cylinder. If ratings are different, relief valve setting should not exceed the setting of the lowest rated component (pump or cylinder).
- The CUSP-Series cylinders are designed for a maximum working pressure of 10,150 psi [700 bar]. Do not connect a pump with a higher pressure rating to these cylinders.
- The CUSP-Series cylinders contain NO stop ring. Advance the plunger slowly to avoid hydraulically ejecting the plunger from the cylinder base. Stop advancing the plunger immediately if the maximum stroke indicator line appears. Refer to sections 6.4, 8.1 and 8.2 of this manual for additional information and precautions.
- Do not exceed equipment ratings. Never attempt to lift a load weighing more than the rated capacity of the cylinder. Overloading may cause equipment failure and possible personal injury.
- Be sure setup is stable before lifting load. Cylinders should be located on a firm and level surface capable of supporting the full load.
- As needed, use a cylinder base plate of appropriate size to provide added stability.
- On the CUSP-Series cylinders, the base plate (if used) must be placed under the cylinder unattached. Do not weld, drill or otherwise modify the cylinder to attach a base plate or other support.
- Always perform a visual inspection of the cylinder before placing it into operation. If any problems are found, do not use the cylinder. Have the cylinder repaired and tested by an Enerpac Authorized Service Center before it is returned to service.
- Never use a cylinder that is leaking oil. Do not use a cylinder that is damaged, altered or in need of repair.
- Always lift the cylinder using a hoist, crane or other suitable lifting device of sufficient rated capacity. Use only the supplied cylinder lifting eyes to attach the cylinder to the lifting device. Replace any missing or damaged lifting eyes.
- Allow only trained and experienced personnel to supervise and perform lifting and lowering procedures.
- Never use a hydraulic cylinder as a shim or spacer in any lifting or pressing application.
- Be certain that the load is centered and covers the entire plunger saddle surface. Avoid situations where loads are not directly centered on the plunger saddle. The load may slip or fall, causing potential danger.
- Lift only dead weight loads. Avoid lifting live weight loads.
- Be especially careful when lifting loads such as partially filled storage tanks, in which the center of gravity could move or shift during lifting. Be aware that the distribution of some loads can change quickly and without warning.
- Do not use the cylinder to lift people. Do not allow people to be on top of the load during lifting or lowering.
- Keep all personnel clear of the work area while lifting or lowering is in progress. To avoid personal injury, keep hands and feet away from cylinder and load during operation.
- Maintain communication with the operator at all times during lifting or lowering to avoid accidents. Use hand signals, two-way radios or other appropriate forms of communication (as required by applicable laws and regulations) if the load is not visible to the operator.
- Operate pump and valve as required to ensure that the load is lifted and lowered evenly and at a controlled rate.
- Closely watch the load at all times during lifting and lowering. Stop lifting or lowering immediately if the load becomes unstable or appears to be lifting or lowering unevenly.
- Stay clear of loads supported only by hydraulics. As required, follow the lifted load with cribbing.
- Always be certain that hydraulic pressure is fully relieved and that the load is fully removed from the cylinder(s) before disconnecting hydraulic hoses, loosening hydraulic fittings, or performing any cylinder disassembly or repair procedures.
- Never allow persons to work under or near the load while the load is being supported hydraulically. After the load has been raised or lowered, it always must be blocked mechanically by a suitable cribbing



Failure to observe and comply with the following precautions could result in minor or moderate personal injury. Property damage could also occur.

- Be careful to avoid damaging hydraulic hoses. Avoid sharp bends and kinks when routing hydraulic hoses. Do not exceed the minimum bend radius specified by the hose manufacturer. Using a bent or kinked hose will cause severe back-pressure. Sharp bends and kinks will internally damage the hose, leading to premature hose failure.
- Do not drop heavy objects on hoses. A sharp impact may cause internal damage to hose wire strands. Applying pressure to a damaged hose may cause it to rupture.
- Do not lift hydraulic equipment by the hoses or couplers. Use the cylinder lifting eyes and appropriately rated lifting equipment.
- Keep hydraulic equipment away from flames and heat. Excessive heat will soften packings and seals, resulting in fluid leaks. Heat also weakens hose materials and packings.
- For optimum performance, do not expose hydraulic equipment to temperatures of 150°F [65°C] or higher. Protect all hydraulic equipment from weld spatter.

- Immediately replace worn or damaged parts with genuine Enerpac parts. Enerpac parts are designed to fit properly and to withstand high loads. Non-Enerpac parts may break or cause the product to malfunction.

NOTICE

- Hydraulic equipment must only be serviced by a qualified hydraulic technician. For repair service, contact the Enerpac Authorized Service Center in your area.
- To help ensure proper operation and best performance, use of Enerpac oil is strongly recommended.

2.3 Additional Safety References

Consult the applicable industry and/or government standards in your country or region for additional safety precautions and work rules applicable to hydraulic cylinders, jacks and other similar lifting equipment.

In the USA, refer to the following publications:

- Code of Federal Regulations - Title 29 Occupational Safety and Health Standards (U.S. Government Publishing Office, 732 North Capitol Street, NW, Washington, DC 20401-0001. www.gpo.gov).
- ASME B30.1 Standards - Jacks (American Society of Mechanical Engineers, Two Park Avenue, New York, NY 10016-5990. www.asme.org).

In the European Union, refer to the standards and directives listed in the product's EU Declaration of Incorporation. A copy of this document is packed separately with the cylinder.

3.0 CONFORMANCE TO NATIONAL AND INTERNATIONAL STANDARDS

CE Enerpac declares that this product has been tested and conforms to applicable standards and is compatible to all CE Requirements. A copy of an EU Declaration of Incorporation is enclosed with each shipment of this product.

4.0 PRODUCT DESCRIPTION

Enerpac CUSP-Series High Tonnage Ultra Flat Cylinders are an ideal solution for lifting applications in which short stroke and low collapsed height is required, and where non-parallel loading surfaces are present.

All CUSP-Series cylinders are single-acting with hydraulic advance and load return. The maximum angle of the tilting plunger is between 2 and 4 degrees.

Capacities range from 10 to 1000 tons [97 to 10165.4 kN]. Refer to the product data markings on the cylinder base for the capacity rating of your cylinder model.

All standard production CUSP-Series cylinders are designed for 10,150 psi [700 bar] maximum working pressure.

The CUSP-Series cylinders have no stop ring. A maximum stroke indicator line alerts the user when the plunger has reached its full allowable extension. Refer to Section 11 of this manual for cylinder weights, oil volumes, dimensions and additional specifications.

5.0 LIFTING THE CYLINDER

All cylinders from CUSP200 to CUSP1000 are equipped with TWO pre-installed lifting eyes. Always use BOTH lifting eyes when hoisting the cylinder.

Lifting straps or chains must be positioned at an angle where they will not interfere with the cylinder base. Use of a spreader bar is recommended. See Figure 2.

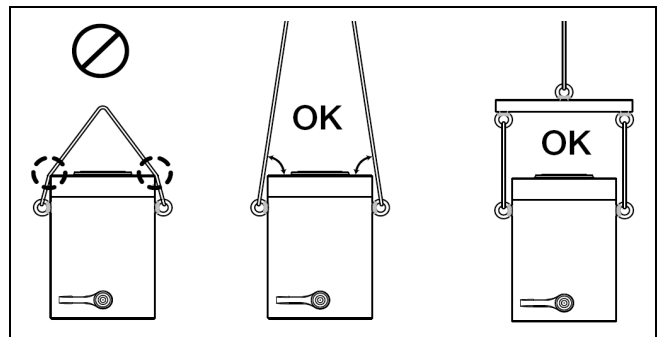

Figure 2, Lifting Arrangements (typical)

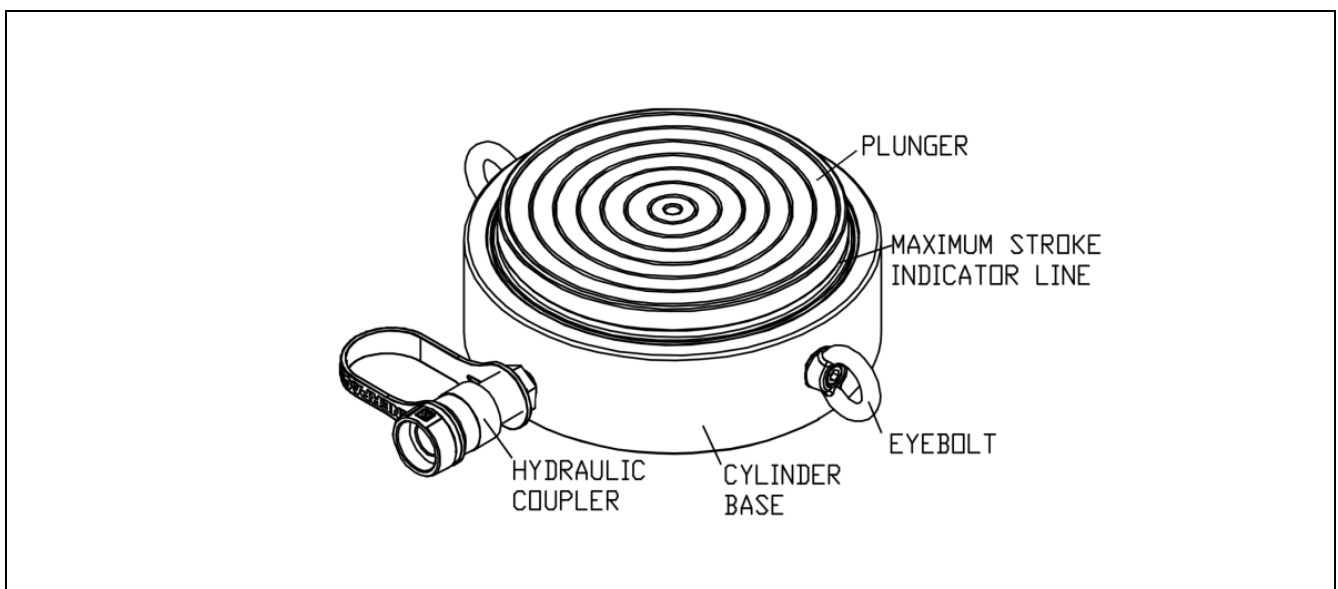

Figure 1, Major Features and Components

6.0 SETUP

6.1 Hydraulic Pump Requirements

Hydraulic pumps are sold separately and are not included with the cylinders.

A hand-operated hydraulic pump can be used to operate a smaller CUSP-Series cylinder. However, a large size cylinder (or a series of coupled cylinders) will typically require the use of an electric, air or gas powered hydraulic pump.

Whichever type of pump is used, be certain that the pump reservoir is capable of holding a sufficient amount of hydraulic oil to operate the cylinder (or set of cylinders) to full extension.

The pump must be equipped with a pressure release valve to allow cylinder retraction. This valve may be either manual or remote operated. Installation of additional devices in the circuit may be required to regulate retract and advance speed.

The pump must also be equipped with a separate safety pressure relief valve that opens if the system working pressure exceeds 10,150 psi [700 bar]. Verify that the pump safety relief valve is adjusted to the proper setting before using the pump with the cylinder(s).

6.2 Hydraulic Oil Requirements

Use of Enerpac HF Series ISO 32 hydraulic oil is recommended. Enerpac HF oil is available at your local Enerpac Distributor or Authorized Service Center.

NOTICE

- Failure to use the correct oil type (high-quality ISO 32 hydraulic oil) may result in damage to cylinder hydraulic components and will void the product warranty.
- Be sure that the oil is clean. The oil cleanliness should be maintained to a maximum level of 18/16/13 per the ISO4406 standard. If the oil develops a milky, cloudy or dark appearance, it should be changed immediately.
- To avoid overfilling and possible equipment damage, add oil to the pump reservoir only after all cylinder plungers are completely retracted and system pressure is released.
- When using a hand-operated pump to power the cylinder(s), it is permissible to use a high-quality brand of ISO 15 hydraulic oil. The lower oil viscosity will result in reduced pumping effort, especially in cold weather conditions.

6.3 Hydraulic Connections

Models CUSP10 to CUSP75 are equipped with one 1/4" – 18 NPTF female coupler. Models CUSP100 to CUSP1000 are equipped with one 3/8"-18 NPTF female coupler. The coupler provides hydraulic flow for both advance and retract functions. Refer to Figure 1 for coupler location.

The coupler on models CUSP10 to CUSP75 is compatible with all Enerpac HB Series hydraulic hoses. The coupler on models CUSP100 to CUSP1000 is compatible with all Enerpac HC Series hydraulic hoses.

Be certain that all couplers are fully connected, so that hydraulic flow is not blocked or restricted.

All hoses, fittings and other hydraulic components in the circuit must be rated for at least 10,150 psi [700 bar] operation.

6.4 Air Removal

Trapped air must be removed from the hydraulic cylinder and hose before placing the system into operation. If multiple cylinders are to be used, it is recommended that air be removed from each cylinder individually. Refer to the following procedure:

1. Place the cylinder in the vertical position, on a flat surface. Be sure that there is no load on the plunger.
2. Position the hydraulic pump so it is located *higher* than the cylinder.

WARNING SLOWLY advance the cylinder plunger during the next step. The CUSP-Series cylinder has NO stop ring. The plunger may be hydraulically ejected from the cylinder base if it is advanced too far. Serious personal injury, high pressure oil leakage and property damage could result.

3. Operate pump and valve to SLOWLY advance the plunger. STOP advancing the plunger immediately when the red maximum stroke indicator becomes visible.
4. Relieve hydraulic pressure. Then, manually retract the plunger into the cylinder base until it is fully retracted. Use of a hydraulic pump equipped with a vacuum valve will help aid plunger retraction.
5. Repeat steps 3 and 4 until the plunger advances smoothly.
6. Be sure that the plunger is fully retracted. Then, check the oil level in the pump hydraulic reservoir. If oil level has dropped, add additional oil to the reservoir as required.

NOTICE Refer to Section 6.2 of this document for hydraulic oil requirements. Follow the pump manufacturer's instructions when adding oil to the pump reservoir. To avoid overfilling, be certain that the cylinder plunger is fully retracted before adding any oil.

7. Repeat steps 1 through 6 for all cylinders to be used in the hydraulic circuit.

6.5 Cylinder Base Support

Be certain to provide adequate support for the cylinder base. All CUSP-Series cylinders require a flat and stable lifting surface that is capable of supporting the load without settling. A one-piece steel plate of appropriate size should be placed between the cylinder base and the ground or other lifting surface. See Figure 3.

CAUTION Use of CUSP-Series cylinders on surfaces such as sand, mud or dirt may result in loss of load and/or damage to cylinder.

Always use a one-piece steel plate under a CUSP-Series cylinder. To ensure proper support, be sure that the plate extends under the entire surface of the cylinder base. The cylinder base may become deformed and permanently damaged if these instructions are not followed.

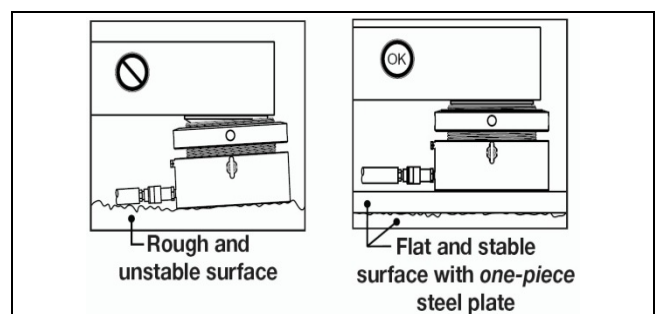

Figure 3, Cylinder Base Support (typical)

7.0 AVOIDING SIDE LOAD

Plan ahead to eliminate the presence of side load forces (offset loading) when using hydraulic cylinders. Side load can occur as a result of one or more of the following conditions:

- An eccentric load on the plunger.
- A horizontal load on a structure.
- A shifting center of gravity.
- Structure and/or cylinder misalignment.
- Non-synchronized lifting actions.
- Non-stable cylinder base support.

It is understood that some side load will occur in many lifting situations. However, the user should do everything possible to minimize or eliminate this condition.

The possibility of side load can be reduced by ensuring that the cylinder base is located on a flat and hard surface, capable of supporting the cylinder and the load without settling.

The CUSP-Series tilt plunger helps compensate for initial misalignment of the load and the saddle surface. It reduces plunger edge loading, which can result in an undesirable off-center load being applied to the plunger.

8.0 OPERATION

Operation procedures will vary, depending on hydraulic pump type, valve configuration and other factors. For detailed operating instructions and related information, refer to the instruction sheet included with your pump. Also follow the additional instructions and precautions contained in sections 8.1, 8.2 and 8.3 of this manual.

8.1 Operating Precautions



Failure to observe the following instructions and precautions could result in serious personal injury, oil leakage and/or property damage.

- CUSP-Series cylinders are NOT equipped with a stop ring. Use these cylinders only in the vertical position with the plunger pointing upwards.
- Advance the plunger slowly. Immediately stop advancing the plunger if the maximum stroke indicator appears or if any oil begins flowing from the plunger stroke limiter port.
- Use extreme caution when using high oil flow pumps with CUSP-Series cylinders. The plunger may advance more quickly than expected.

NOTICE It is mandatory that the operator has a full understanding of all instructions, safety precautions and applicable safety regulations before operating any high force hydraulic equipment. If questions or concerns, contact your local Enerpac Distributor or Authorized Service Center.

8.2 Maximum Stroke Indicator Line

The cylinder plunger contains a maximum stroke indicator line. See figures 4 and 5, item A. When this indicator line becomes visible, the plunger has reached its maximum allowable stroke. Advancement of the plunger must stop **immediately**.



Failure to observe the following instructions could result in catastrophic failure, erratic operation, high pressure oil leakage and/or damage to cylinder. Death or serious personal injury could result.

If the plunger is not tilted, the entire maximum stroke indicator line will be visible as shown in Figure 4. **Stop** advancing the plunger immediately when the indicator line becomes visible.

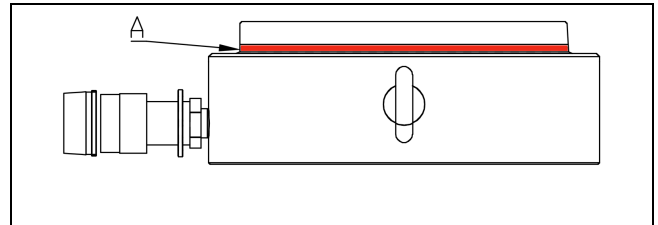

**Figure 4, Maximum Stroke Indicator Line (A)
Max. stroke position when plunger is level.**

- If the plunger is tilted, the maximum stroke indicator line will be visible only on the **high side** of the plunger as shown in Figure 5. **Stop** advancing the plunger immediately when the **high side** of the indicator line becomes visible. **Do not** continue advancing the plunger so that the indicator line is completely visible.

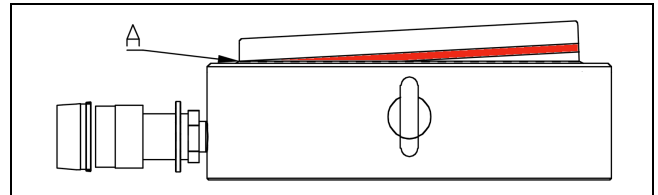

**Figure 5, Maximum Stroke Indicator Line (A)
Max. stroke position when plunger is tilted at an angle.**



Continuing to advance the cylinder plunger beyond the maximum allowable stroke could result in the plunger being hydraulically ejected from the cylinder base, especially if the plunger is advanced quickly. Death or serious personal injury could result.

8.3 Operating Instructions

To advance: Operate pump and valve so that pressurized oil flow is directed in a controlled rate from the pump reservoir to the cylinder coupler.

To retract: Operate pump and valve so that hydraulic oil is directed at a controlled rate from the cylinder coupler back to the pump reservoir.

Note that additional hydraulic components may be required to control the rate at which the plunger retracts under load.

NOTICE CUSP-Series cylinders contain no plunger return spring. External force will be required to fully retract the plunger if it is not under load. A hydraulic pump equipped with a vacuum valve will help aid plunger retraction.

9.0 INSPECTION, MAINTENANCE & STORAGE

- Periodically check the hydraulic system for loose connections leaks and obvious problems. Replace any damaged components immediately.
- Monitor the oil temperature during operation. Do not exceed oil temperatures above 150°F [65°C].

- Install dust cap(s) and plug(s) after the hydraulic hoses are disconnected from the cylinder.
- Keep all hydraulic components clean.
- Change the hydraulic oil at the recommended interval shown in the pump instruction sheet. Change the oil immediately if contamination is suspected.
- Store cylinders in the upright position, in a clean, dry and secure location. Keep stored cylinders and hoses away from heat and direct sunlight.
- If repairs are required, refer to the Enerpac website for the repair parts sheet applicable to your cylinder model.

10.0 TROUBLESHOOTING

Refer to the troubleshooting guide when diagnosing cylinder operational problems. Please note that the troubleshooting guide is not all-inclusive, and should be considered only as an aid to help diagnose the most common possible problems.

For repair service, contact your nearest Enerpac Authorized Service Center. As required, also refer to the troubleshooting information provided with your hydraulic pump or power unit.

NOTICE Hydraulic equipment must only be serviced by a qualified hydraulic technician. For repair service, contact the Enerpac Authorized Service Center in your area.

<i>Troubleshooting Guide</i>		
Symptom	Possible Cause	Solution
1. Plunger will not advance.	a. Pump release valve open.	Close pump release valve.
	b. Directional control valve not in proper position.	Shift directional control valve to proper position.
	c. Coupler not fully tightened.	Tighten coupler.
	d. Pump oil level is low.	Add oil to pump reservoir as required. See Section 6.2.
	e. Pump malfunctioning.	Repair or replace pump as required.
	f. Cylinder load rating too low for application.	Use a cylinder with a higher load rating.
	g. Cylinder seals leaking.	Repair or replace cylinder.
2. Plunger advances only part way.	a. Oil level in pump is low.	Add oil to pump reservoir as required. See Section 6.2.
	b. Coupler is not fully tightened.	Tighten coupler.
	c. Cylinder plunger binding.	Repair or replace cylinder.
3. Plunger advances erratically.	a. Air in hydraulic system.	Remove air from hydraulic system. See Section 6.4.
	b. Cylinder plunger binding.	Repair or replace cylinder.
4. Plunger advances more slowly than normal.	a. Leaking connection.	Repair leaking connection.
	b. Coupler not fully tightened.	Tighten coupler.
	c. Pump malfunctioning.	Repair or replace pump as required.
5. Plunger advances, but will not hold.	a. Pump malfunctioning.	Repair or replace pump as required.
	b. Leaking connection.	Repair leaking connection.
	c. Incorrect system set-up.	Check hose connections at pump and cylinders.
	d. Cylinder seals leaking.	Repair or replace cylinder.
6. Cylinder leaks oil.	a. Worn or damaged cylinder seals.	Repair or replace cylinder.
	b. Internal cylinder damage.	Repair or replace cylinder.
	c. Loose connection.	Tighten or repair connection.
7. Plunger will not retract or retracts more slowly than normal.	a. Pump release valve closed.	Open pump release valve.
	b. Directional control valve not in proper position.	Shift directional control valve to proper position.
	c. Pump reservoir is overfilled.	Drain oil from pump reservoir as required.
	d. Improper hose connections.	Check hose connections.
	e. Narrow hose restricting oil flow.	Replace with larger diameter hose.
	f. Internal cylinder damage.	Repair or replace cylinder.

11.0 PRODUCT DATA

11.1 Dimensions – Imperial (see Figure 6)

Cylinder Model Number	Collapsed Height	Extended Height Straight	Outside Diameter	Cyl. Bore Diameter	Base to Advance Port
	A	B	D	E	H
	in	in	in	in	in
CUSP10	1.40	1.66	2.83	1.65	0.55
CUSP20	1.59	1.87	3.54	2.36	0.55
CUSP30	1.67	1.96	4.13	2.95	0.55
CUSP50	2.24	2.77	5.12	3.94	0.62
CUSP75	2.38	2.93	5.91	4.72	0.69
CUSP100	2.50	3.08	6.69	5.51	0.75
CUSP150	2.56	3.12	7.87	6.69	0.84
CUSP200	2.72	3.30	9.02	7.68	0.95
CUSP250	2.85	3.46	9.92	8.46	1.04
CUSP300	2.85	3.41	11.10	9.45	1.17
CUSP400	3.05	3.63	12.44	10.63	1.30
CUSP500	3.25	3.85	14.02	12.01	1.45
CUSP600	3.44	4.06	15.20	12.99	1.58
CUSP750	3.68	4.32	17.01	14.57	1.76
CUSP1000	4.06	4.74	19.76	16.93	2.05

11.2 Dimensions – Metric (see Figure 6)

Cylinder Model Number	Collapsed Height	Extended Height Straight	Outside Diameter	Cyl. Bore Diameter	Base to Advance Port
	A	B	D	E	H
	mm	mm	mm	mm	mm
CUSP10	35.5	42.2	72	42	14.0
CUSP20	40.5	47.5	90	60	14.0
CUSP30	42.5	49.8	105	75	14.0
CUSP50	57.0	70.3	130	100	15.8
CUSP75	60.5	74.5	150	120	17.6
CUSP100	63.5	78.2	170	140	19.1
CUSP150	65.0	79.3	200	170	21.3
CUSP200	69.0	83.9	229	195	24.2
CUSP250	72.5	88.0	252	215	26.5
CUSP300	72.5	86.6	282	240	29.7
CUSP400	77.5	92.1	316	270	33.0
CUSP500	82.5	97.7	356	305	36.9
CUSP600	87.5	103.1	386	330	40.2
CUSP750	93.5	109.8	432	370	44.7
CUSP1000	103.0	120.4	502	430	52.1

11.3 Specifications – Imperial

Cylinder Model Number	Stroke	Straight Stroke	Tilting +/-	Cylinder Class	Maximum Capacity		Effective Area	Oil Capacity	Weight
	in	in	(deg.)		US Ton	lb	in ²	in ³	lb
CUSP10	0.24	0.26	2	10	10.9	21,801	2.15	0.57	2.6
CUSP20	0.24	0.28	2	20	22.2	44,492	4.38	1.21	4.2
CUSP30	0.24	0.29	2	30	34.8	69,520	6.85	1.97	6.0
CUSP50	0.39	0.52	4	50	61.8	123,590	12.17	6.37	12.3
CUSP75	0.39	0.55	4	75	89.0	177,970	17.53	9.66	17.6
CUSP100	0.39	0.58	4	100	121.1	242,237	23.86	13.81	23.8
CUSP150	0.39	0.56	3	150	178.6	357,176	35.18	19.81	33.7
CUSP200	0.39	0.59	3	200	235.0	469,952	46.29	27.15	47.4
CUSP250	0.39	0.61	3	250	285.6	571,296	56.27	34.34	60.2
CUSP300	0.39	0.56	2	300	355.9	711,880	70.12	38.93	75.8
CUSP400	0.39	0.57	2	400	450.5	900,973	88.75	51.01	101.9
CUSP500	0.39	0.60	2	500	574.8	1,149,698	113.25	67.77	138.2
CUSP600	0.39	0.61	2	600	672.9	1,345,898	132.57	81.42	172.8
CUSP750	0.39	0.64	2	750	846.0	1,691,951	166.66	106.95	231.9
CUSP1000	0.39	0.69	2	1000	1,142.6	2,285,184	225.09	154.20	346.1

11.4 Specifications – Metric

Cylinder Model Number	Tilted Stroke	Straight Stroke	Tilting +/-	Cylinder Class	Maximum Capacity		Effective Area	Oil Capacity	Weight
	mm	mm	(deg.)		kN	Tonnes	cm ²	cm ³	Kg
CUSP10	6	6.7	2	10	97.0	9.9	13.9	9.3	1.2
CUSP20	6	7.0	2	20	197.9	20.2	28.3	19.8	1.9
CUSP30	6	7.3	2	30	309.3	31.5	44.2	32.3	2.7
CUSP50	10	13.3	4	50	549.8	56.1	78.5	104.5	5.6
CUSP75	10	14.0	4	75	791.7	80.7	113.1	158.3	8.0
CUSP100	10	14.7	4	100	1,077.6	109.9	153.9	226.3	10.8
CUSP150	10	14.3	3	150	1,588.9	162.0	227.0	324.6	15.3
CUSP200	10	14.9	3	200	2,090.5	213.2	298.6	445.0	21.5
CUSP250	10	15.5	3	250	2,541.4	259.1	363.1	562.7	27.3
CUSP300	10	14.1	2	300	3,166.7	322.9	452.4	637.9	34.4
CUSP400	10	14.6	2	400	4,007.9	408.7	572.6	835.9	46.2
CUSP500	10	15.2	2	500	5,114.3	521.5	730.6	1,110.5	62.7
CUSP600	10	15.6	2	600	5,987.1	610.5	855.3	1,334.3	78.4
CUSP750	10	16.3	2	750	7,526.5	767.5	1,075.2	1,752.6	105.2
CUSP1000	10	17.4	2	1000	10,165.4	1,036.6	1,452.2	2,526.8	157.0

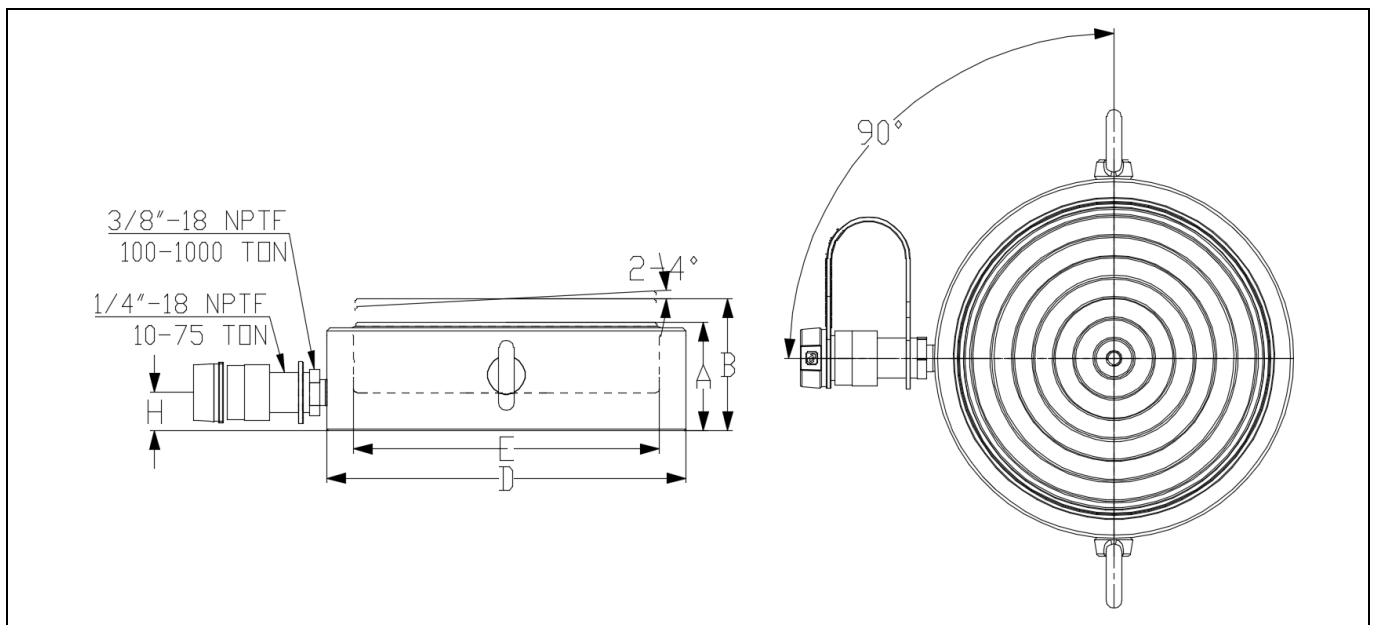

Figure 6, Dimensions – CUSP-Series