

L4353

Rev. B

07/19

To protect your warranty, use only ENERPAC hydraulic oil.

Models:

- EP3104DB
- EP3104DI
- EP3104DE

For use with single-acting hydraulic tools.

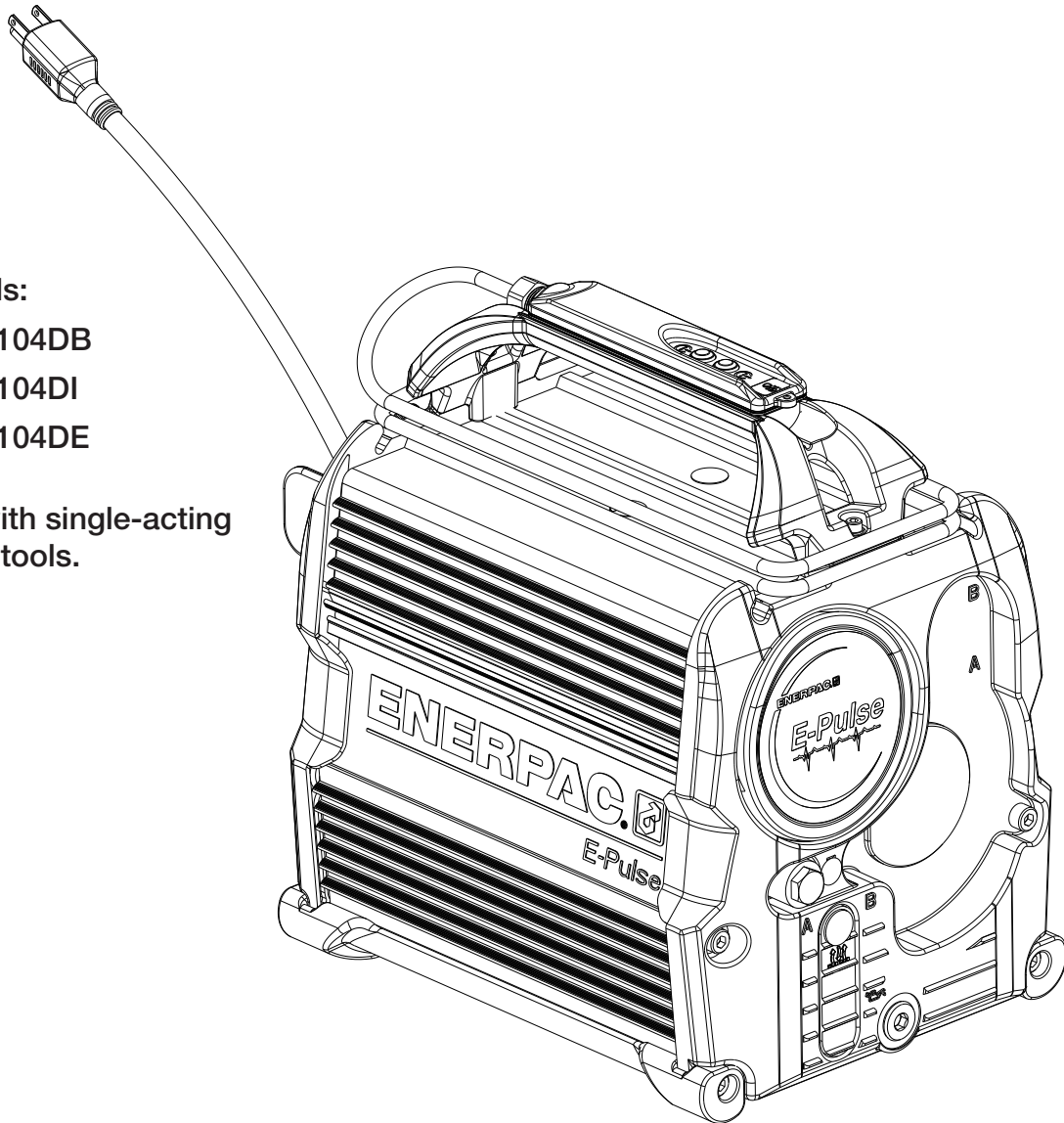

## Table of Contents:

<p><b>1.0 SAFETY.....3</b></p> <p>    1.1 Important Safety Instructions.....3</p> <p>    1.2 General Hydraulic Safety Precautions..3</p> <p>    1.3 Electrical Safety.....4</p> <p>    1.4 Additional Precautions.....5</p> <p>    1.5 IP Ratings (Ingress Protection, IEC standard 60529) .....5</p> <p>    1.6 Safety Hazard Alert Symbols.....5</p> <p><b>2.0 PRODUCT DATA.....6</b></p> <p>    2.1 Specifications .....6</p> <p>    2.2 External Dimensions .....6</p> <p>    2.3 Pump Performance Curves .....7</p> <p><b>3.0 MAJOR FEATURES AND COMPONENTS.....8</b></p> <p><b>4.0 PRODUCT DESCRIPTION.....9</b></p> <p>    4.1 Introduction.....9</p> <p>    4.2 Intended Use.....9</p> <p>    4.3 Conformance to National &amp; International Standards.....9</p> <p>    4.4 Electromagnetic Compatibility (EMC) .9</p> <p><b>5.0 PREPARATION FOR USE .....9</b></p> <p>    5.1 Important Receiving Instructions.....9</p> <p>    5.2 Hydraulic Connections.....9</p> <p>    5.3 Hydraulic Reservoir .....10</p> <p>    5.4 Hydraulic Reservoir Air Breather/Filter.....10</p> <p>    5.5 Power Requirements.....10</p> <p><b>6.0 FEATURES AND CONTROLS.....10</b></p> <p>    6.1 Carrying Handle.....10</p>	<p>    6.2 Ventilation System .....10</p> <p>    6.3 Pendant .....10</p> <p>    6.4 3-Way, 2-Position Pilot Operated Control Valve.....11</p> <p>    6.5 Variable Speed Control .....11</p> <p>    6.6 Constant Speed and Constant Power Modes.....11</p> <p><b>7.0 OPERATION.....12</b></p> <p>    7.1 Before Start-up .....12</p> <p>    7.2 Pump Operating Positions .....12</p> <p>    7.3 Air Removal .....12</p> <p>    7.4 Operating Precautions .....12</p> <p>    7.5 Important Use and Application Information.....13</p> <p>    7.6 Pump Operation.....13</p> <p><b>8.0 RELIEVING HYDRAULIC PRESSURE .....13</b></p> <p><b>9.0 PRESSURE RELIEF VALVE ADJUSTMENT..13</b></p> <p><b>10.0 HYDRAULIC SYSTEM MAINTENANCE.....14</b></p> <p>    10.1 Hydraulic Oil Information .....14</p> <p>    10.2 Checking the Oil Level .....14</p> <p>    10.3 Adding Oil.....15</p> <p>    10.4 Oil Change.....16</p> <p>    10.5 Pump Priming/Air Purging .....16</p> <p><b>11.0 CLEANING AND INSPECTION .....16</b></p> <p><b>12.0 STORAGE .....16</b></p> <p><b>13.0 TROUBLESHOOTING .....16</b></p> <p><b>14.0 PUMP FAULT CODES (user-level) .....19</b></p>
--	---

## 1.0 SAFETY

### 1.1 Important Safety Instructions

Read all instructions carefully. Follow all recommended safety precautions to avoid personal injury as well as damage to the pump and/or damage to other property. Enerpac cannot be responsible for any damage or injury from unsafe use, lack of maintenance or incorrect operation. Do not remove warning labels, tags, or decals. In the event any questions or concerns arise, contact Enerpac or a local Enerpac distributor for clarification.

#### SAVE THIS INSTRUCTION SHEET FOR FUTURE USE

Appropriate training in the safe use of high pressure, high force hydraulic tools is required prior to the operation of the pump. If training is needed, contact your local Enerpac distributor or authorized service center for information about an Enerpac hydraulic safety training course.

This manual follows a system of safety alert symbols, signal words and safety messages to warn the user of specific hazards. Failure to comply with these warnings could result in death or serious personal injury, as well as damage to the equipment or other property.



The **Safety Alert Symbol** appears throughout this manual. It is used to alert you to potential physical injury hazards. Pay close attention to Safety Alert Symbols and obey all safety messages that follow this symbol to avoid the possibility of death or serious personal injury.

Safety Alert Symbols are used in conjunction with certain Signal Words that call attention to safety messages or property damage messages and designate a degree or level of hazard seriousness. The Signal Words used in this manual are DANGER, WARNING, CAUTION and NOTICE.



Indicates a hazardous situation that, if not avoided, **will** result in death or serious personal injury.



Indicates a hazardous situation that, if not avoided, **could** result in death or serious personal injury.



Indicates a hazardous situation that, if not avoided, **could** result in minor or moderate personal injury.



Indicates information considered important, but not hazard related (e.g. messages relating to property damage). Please note that the Safety Alert Symbol will **not** be used with this signal word.

## 1.2 General Hydraulic Safety Precautions



**Failure to observe and comply with the following precautions could result in death or serious personal injury. Property damage could also occur.**

- Do not remove or disable the pressure relief valve.
- Never set the pressure relief valve to a higher pressure than the maximum rated pressure of the pump.
- Stay clear of hydraulic tools while they are being pressurized or in operation. To avoid personal injury, keep hands and feet away from pinch point areas.
- Do not handle pressurized hydraulic hoses. Escaping oil under pressure can penetrate the skin. If oil is injected under the skin, see a doctor immediately.
- Do not pressurize disconnected couplers.
- Never use a hydraulic cylinder or tool as a shim or spacer in any application.
- Avoid situations where loads are not directly centered on the tool plunger. Off-center loads produce considerable strain on plungers. The tool may also slip out of position.
- The system operating pressure must not exceed the pressure rating of the lowest rated component in the system. Install pressure gauge(s) in the system to monitor operating pressure. It is your window to see what is happening in the system.
- Do not exceed equipment ratings. Overloading causes equipment failure and possible personal injury.
- Wear personal protective equipment (P.P.E.) when operating hydraulic equipment. Always wear eye protection. Safety equipment such as dust mask, non-skid safety shoes, hard hat, or hearing protection used for appropriate conditions will reduce personal injuries.
- Immediately replace worn or damaged parts with genuine ENERPAC parts. Standard grade parts will break causing personal injury and property damage.



**Failure to observe and comply with the following precautions could result in minor or moderate personal injury. Property damage could also occur.**

- Do not use or repair damaged hydraulic hoses. Avoid sharp bends and kinks when routing hydraulic hoses. Using a bent or kinked hose will cause severe back-pressure. Sharp bends and kinks will internally damage the hose, leading to premature hose failure.
- Do not drop heavy objects on hydraulic hoses. A sharp impact may cause internal damage to hose wire strands. Applying pressure to a damaged hose may cause it to rupture.
- Do not lift hydraulic equipment by the hoses or swivel couplers. Use the carrying handle or strap.
- Keep hydraulic equipment away from flames and heat. Excessive heat will soften packings and seals, resulting in fluid leaks. Heat also weakens hose materials and packings.
- Protect all hydraulic equipment from weld spatter.
- Immediately replace worn or damaged parts with genuine Enerpac parts. Enerpac parts are designed to fit properly and to withstand high loads. Non-Enerpac parts may break or cause the pump to malfunction.

**NOTICE** Hydraulic equipment must only be serviced by a qualified hydraulic technician. For repair service, contact the Enerpac Authorized Service Center in your area

## 1.3 Electrical Safety

### 1.3.1 Electrical Safety Precautions



**Failure to observe the following instructions and precautions may result in serious personal injury or death.**

- High voltage is present inside the pump even when motor is off. Before opening the pump housing or performing any maintenance or repairs, be sure that the pump power cord is disconnected from the electrical outlet or other electrical power source.
- Always be certain that the pump is stopped and disconnected from AC power supply before performing any inspection, maintenance or repair procedures.
- Do not leave the pump unattended in the workplace when connected to AC power supply. Take all reasonable precautions to avoid unauthorized use.
- Take precautions so that the pump is not switched on accidentally.
- If it is not possible to unplug the pump power cord from the AC power outlet, the power must be turned off and locked out at the AC power supply.
- Always disconnect the pump from AC power before transporting it.
- Do not use the pump if it cannot be switched on and off using the pendant. Pump must be repaired before use.
- Make sure the pump cooling vents are unobstructed and free of dirt or dust.
- Do not service or clean the pump while the pump is operating and/or if pump is connected to AC power supply.
- Keep the pump out of the reach of children. Do not allow inexperienced users or users who have not read the instructions to operate them.

### 1.3.2 Use and Care



**Failure to observe and comply with the following precautions could result in death or serious personal injury. Property damage could also occur.**

- Store the pump indoors. Keep in a secured area to prevent use by unauthorized personnel.
- Do not clean the pump with a water spray or the like.
- Do not operate the pump with a damaged cord or plug, or after the pump malfunctions or is dropped or damaged in any manner. Return the pump to the nearest Enerpac authorized service center for examination, repair, or electrical or mechanical adjustment.

### 1.3.3 Disconnecting Power



**Failure to observe and comply with the following precautions could result in death or serious personal injury. Property damage could also occur.**

- Be sure that the pump is off before removing plug from electrical outlet.
- Do not unplug the pump by pulling on the cord. To unplug, grasp the plug, not the cord.
- Remove plug from electrical outlet when the pump is not in use and before servicing or cleaning the pump.

### 1.3.4 Grounding Instructions



**Failure to observe the following instructions and precautions may result in serious personal injury or death.**

- The pump must be properly grounded. In the event of malfunction or breakdown, grounding provides a path of least resistance for electric current to reduce the risk of electric shock. The pump is equipped with a cord having an equipment grounding conductor.
- A grounding plug is included with the cord. The plug must be plugged into an appropriate outlet that is properly installed and grounded in accordance with all local codes and ordinances.
- Improper connection of the pump grounding conductor can result in electric shock. The conductor with insulation having an outer surface that is green with or without yellow stripes is the pump grounding conductor.
- If the cord and/or plug are damaged, do not connect the pump to a live electrical outlet. Repair or replace the damaged items as required and be sure the grounding conductor is properly wired before reconnecting the pump to the outlet. Consult a qualified electrician if grounding conductor wiring procedures are not completely understood or if there is any doubt as to whether the pump is properly grounded.
- Do not modify the plug provided with the pump. If the plug will not fit in the outlet, have a proper outlet installed by a qualified electrician.
- A qualified electrician should be consulted if there is any doubt as to whether an outlet box is properly grounded.
- The pump is equipped with an electric power cord and plug specific to its rated single-phase voltage. No adapter should be used with the plug.
- If the pump must be reconnected for use on a different type of electric circuit, the reconnection should be made by a qualified electrician. After the reconnection, the pump should comply with all local codes and ordinances.

### 1.3.5 Use Of Extension Cords



Failure to observe the following instructions and precautions may result in serious personal injury or death.

- Use the proper size extension cord with the pump power cord when use of an extension cord is necessary. A qualified electrician should be consulted to help specify and select the proper size extension cord. The marked electrical rating of the extension cord should be at least as great as the electrical rating of the pump.
- The extension cord should be a grounding-type 3-wire cord for single-phase power.
- A long extension cord should be arranged so that it will not drape over any working area where it can be tripped over, snagged, or pulled on unintentionally.
- If the pump is to be operated outdoors and an extension cord is needed, use only an outdoor-use extension cord. An outdoor-use extension cord will be clearly marked with the suffix letter “W” and the statement “Suitable for Use with Outdoor Appliances.”

### 1.4 Additional Precautions

**WARNING** Do not use electric pumps in an explosive atmosphere. Sparks and electrical arcing could ignite combustible vapors or airborne dust

**CAUTION** Check electrical power requirements on pump data plate. Power of incorrect specifications may damage the motor.

### 1.5 IP Ratings

(Ingress Protection, IEC standard 60529)

- The pump IP rating is IP54.
- The pendant IP rating is IP67.
- Outdoor use is permitted.
- Exposure to dust and moisture is permitted in accordance with the stated IP rating. However, the pump should be stored in a dry and protected environment when not in use.
- Do not immerse the pump in water or other liquids.
- Do not allow water jets to contact the pump.

### 1.6 Safety Hazard Alert Symbols

**WARNING** Failure to observe and comply with the safety hazard alert symbols affixed to the pump could result in death or serious personal injury.

Safety hazard alert symbols (decals, labels, etc.) are affixed to the pump. Observe these symbols and understand their meaning before using the pump.



**Read instructions:** Read the product instruction sheet before operating the product and before performing any inspection, adjustment, maintenance or repair procedures. (Figure 1, item A)

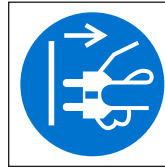

**Disconnect Electrical Power:** To avoid the possibility of a dangerous and potentially lethal electrical shock, disconnect pump power cord from AC electrical power supply before opening the pump case. (Figure 1, Item B)

Make sure the safety hazard alert symbols are legible and securely affixed to the pump. If worn or missing, obtain replacements from Enerpac. Refer to Figure 1 for locations

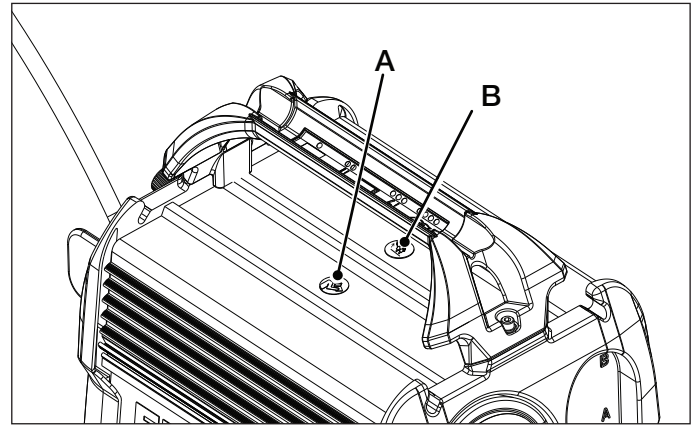

Figure 1, Locations of Safety Hazard Alert Symbols

## 2.0 PRODUCT DATA

### 2.1 Specifications

Pump Model Number	Control Valve Description	For Use With:	Hydraulic Connections	Weight*		Usable Oil Capacity**		Oil Type
				lb	kg	gal.	l	
EP3104D_	3-way, 2-position Advance / Retract (pilot-operated dump)	Single-acting hydraulic tools	3/8" NPTF	39.8	18.1	0.8	3.0	Enerpac HF

\* Approximate weight of pump including oil.  
 \*\* Approximate usable oil capacity of pump hydraulic reservoir (excludes pump element).  
 Pump total oil capacity (including reservoir and pump element housing) is approximately 1.14 gallons [4.33 liters].

Pump Model Number	Pump Type	Maximum Hydraulic Working Pressure *		Flow Rate at Maximum Speed								Motor Speed Range **
				At 14.5 psi [1 bar]		At 2538 psi [175 bar]		At 5075 psi [350 bar]		At 10,000 psi [700 bar]		
				psi	bar	in <sup>3</sup> /min	l/min	in <sup>3</sup> /min	l/min	in <sup>3</sup> /min	l/min	in <sup>3</sup> /min
EP3104D_	2 Stage	10,000	700	220	3.61	130	2.13	58	0.95	32	0.52	600-2400

\* Maximum pressure setting of pump is limited to approximately 10,300 -10,800 psi [710-745 bar].  
 \*\* Refer to Section 6.5 for additional information.

Pump Model Number Ending In:	Input Power Specifications					Plug Type	Motor Output Rating		Operating Temp Range *		Sound Level Lwa **
	Nominal Voltage Range	Phase	Hz	Max. Amps	Max. kW		hp	kW	°F	°C	dB
B	100-120 VAC	1	50-60	12.0	1.12	NEMA 5-15	0.85	0.63	-22 to +122	-30 to +50	70-85
I	200-250 VAC	1	50-60	7.0	1.28	NEMA 6-15	0.85	0.63	-22 to +122	-30 to +50	70-85
E	200-250 VAC	1	50-60	7.0	1.28	Schuko CEE 7/7	0.85	0.63	-22 to +122	-30 to +50	70-85

\* At 85% relative humidity. \*\* Sound level will vary depending on pump speed and load.

### 2.2 External Dimensions

Item	Dimension	
	inch	mm
A	10.2	259
B	14.2	361
C	14.0	356
	ft	m
D (pendant cable)	10	3.0
E (power cord)	2.0	0.6

**Note:** Dimensions shown are applicable to all pump models included in this document.

## 2.3 Pump Performance Curves

### Model EP3104DB

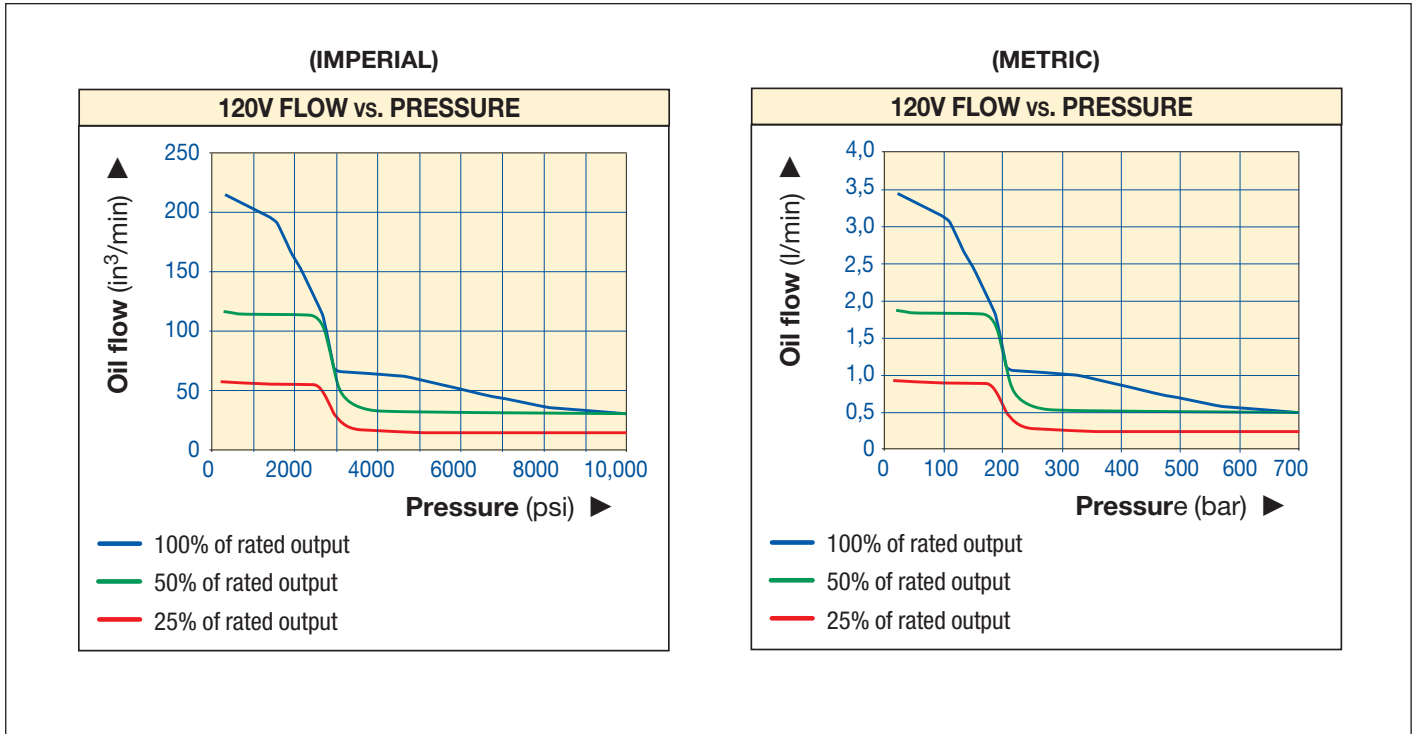

### Models EP3104DE and EP3104DI

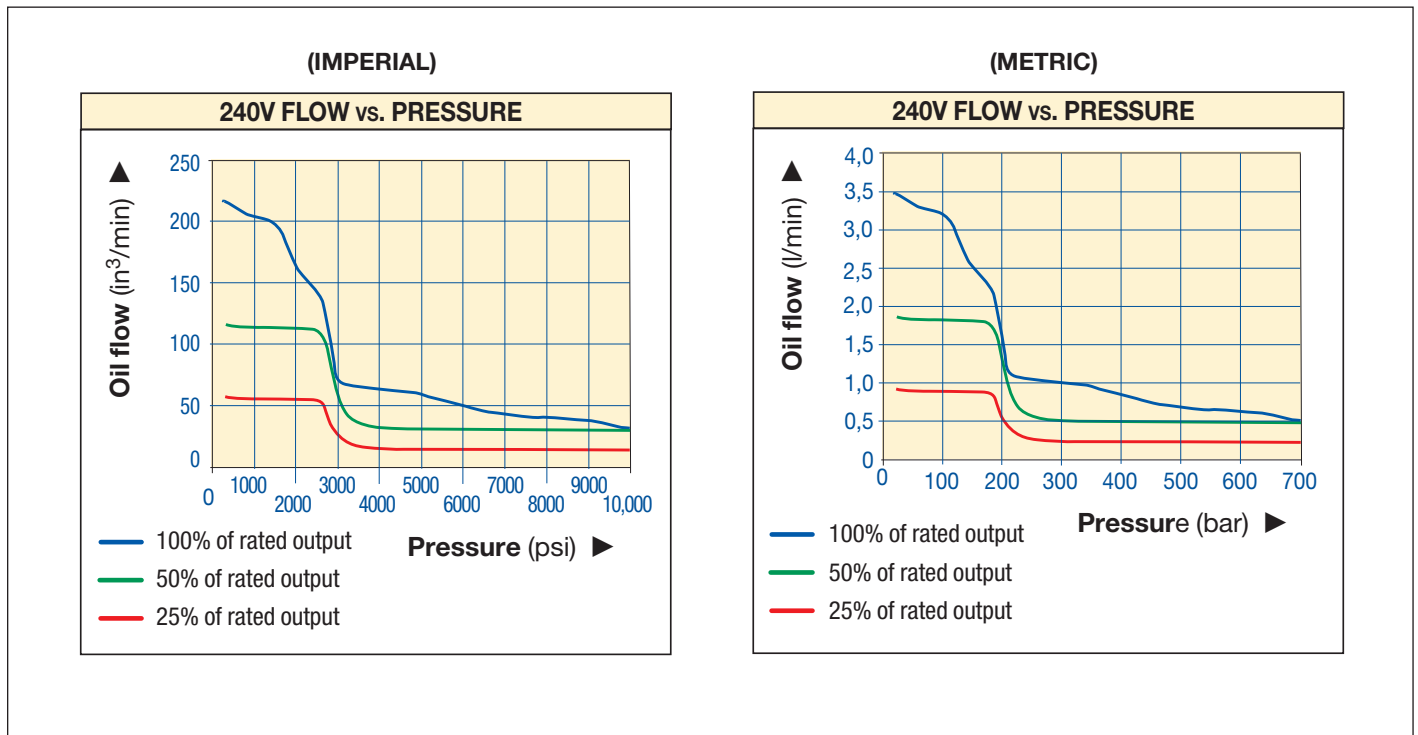

### 3.0 MAJOR FEATURES AND COMPONENTS

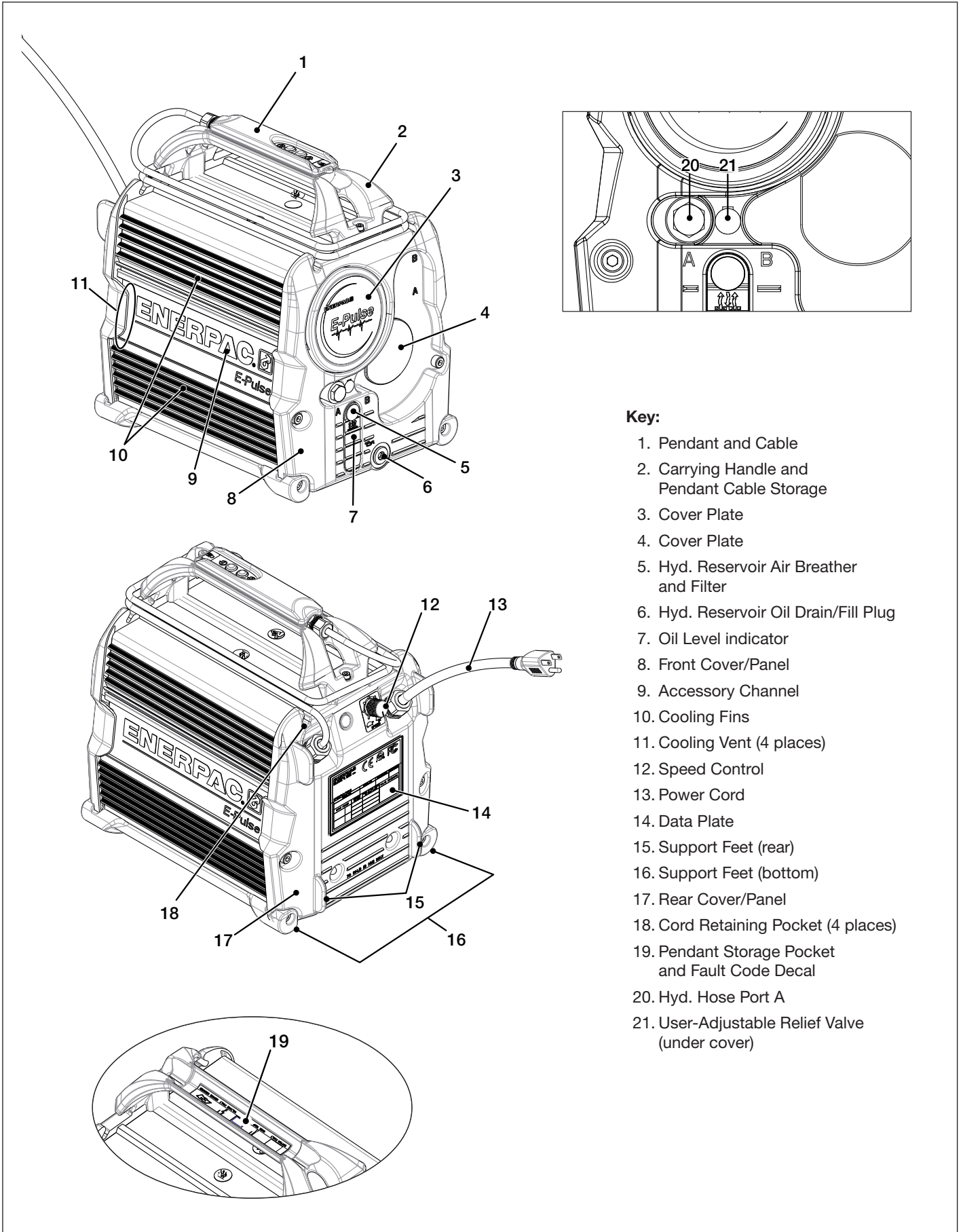

- Key:**
1. Pendant and Cable
  2. Carrying Handle and Pendant Cable Storage
  3. Cover Plate
  4. Cover Plate
  5. Hyd. Reservoir Air Breather and Filter
  6. Hyd. Reservoir Oil Drain/Fill Plug
  7. Oil Level indicator
  8. Front Cover/Panel
  9. Accessory Channel
  10. Cooling Fins
  11. Cooling Vent (4 places)
  12. Speed Control
  13. Power Cord
  14. Data Plate
  15. Support Feet (rear)
  16. Support Feet (bottom)
  17. Rear Cover/Panel
  18. Cord Retaining Pocket (4 places)
  19. Pendant Storage Pocket and Fault Code Decal
  20. Hyd. Hose Port A
  21. User-Adjustable Relief Valve (under cover)

Figure 2, Major Features and Components, E-Series Electric Dump Pump



## 4.0 PRODUCT DESCRIPTION

### 4.1 Introduction

The Enerpac E-Series electric dump pump is designed for use with single-acting hydraulic tools rated at 10,000 psi [700 bar] working pressure.

Features include:

- Pilot-operated 3-way 2-position dump valve automatically relieves hydraulic pressure when motor is stopped.
- Remote control 2-button *Smart IQ* pendant with LED status and diagnostic indicator.
- Variable speed permanent magnet direct drive motor with unique *constant power* feature.
- Choice of *jog* (momentary on) or *latched* (constant on) operational modes.
- Durable and lightweight all aluminum chassis construction.
- Two-stage pump design for fast system fills and controlled flow at high pressures.
- Six discreet pump elements provide even flow and smooth operation.
- Built-in user and service center diagnostic features.

Refer to Figure 2 for a diagram of the pump's major features and components.

### 4.2 Intended Use

The E-Series electric dump pump (Models EP3104DB, EP3104DE & EP3104DI) is intended for applications in which load holding is NOT required. It is expressly designed for use with single-acting hydraulic tools that have no lifting or load holding function, such as most cutters, punches, pullers and other similar devices. Refer to Section 7.5 of this manual for additional use and application information.

**⚠ WARNING** Use of the E-Series electric dump pump in load holding applications could result in persons becoming crushed by falling loads or objects under tension. Death or serious personal injury could result.

### 4.3 Conformance to National & International Standards

**CE** Enerpac declares that the E-Series pumps have been tested and conform to applicable standards and are approved to carry the CE, TUV C and US, and FCC certification marks. An EU declaration of conformity is included in the shipment.

### 4.4 Electromagnetic Compatibility (EMC)

Enerpac E-Series pumps have been tested and certified to conform to CE-EMC Emission and Immunity standards and to FCC emission standards.

## 5.0 PREPARATION FOR USE

### 5.1 Important Receiving Instructions

Visually inspect all components for shipping damage. Shipping damage is not covered by warranty. If shipping damage is found, notify carrier at once. The carrier is responsible for all repair and replacement costs resulting from damage in shipment.

Note that a small amount of residual hydraulic oil may be present within the packaging from product final assembly and testing procedures. In addition, a small amount of hydraulic oil may leak from the reservoir air breather (covered by a removable absorbent pad) during shipping. A minimal amount of oil inside the shipment should be considered as normal and not as a cause for concern.

### 5.2 Hydraulic Connections

As hydraulic hoses, fittings and components are assembled, apply 1-½ wraps of PTFE thread sealing tape to all threaded NPT or NPTF fittings, leaving the first complete thread free of tape as shown in Figure 3. Use care to prevent pieces of tape from entering the hydraulic system.

All hoses, fittings and components used with the pump must be rated for at least 10,000 psi [700 bar] operation.

**⚠ WARNING** Avoid kinking or tightly bending hoses. Do not exceed the hose manufacturer's stated minimum bend radius. If a hose becomes kinked or otherwise damaged, it must be replaced. Damaged hoses may rupture at high pressure. Serious personal injury may result.

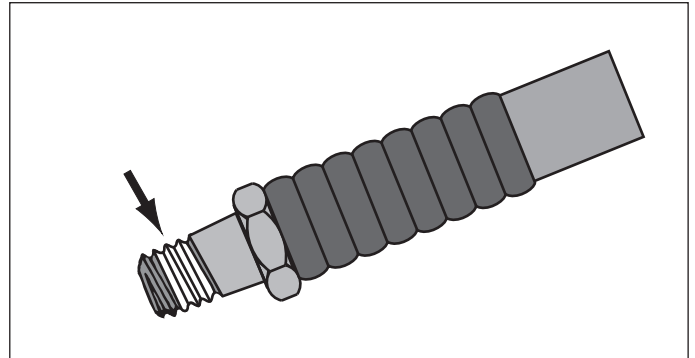

Figure 3, Hydraulic Sealing Tape Application

Hydraulic hose port “A” is a ¾” -18 NPTF female connection. Port “B” is not used on this pump model. See Figure 4.

Make hydraulic connections as described in the following steps:

1. To prevent the pump from starting, be sure that the pump power cord is disconnected from the AC power source.

**⚠ WARNING** A small amount of oil leakage or spray may occur when plug is loosened in the following step. To prevent eye injury, keep face away from this area when plug is loosened.

2. Remove the plug from hydraulic hose port “A”.
3. As required, install hydraulic fitting(s) or coupler in hose port “A”. Tighten until finger tight. Then tighten an additional 1.5 to 3.0 turns or torque to 40 ft. lb [54.2 Nm].
4. Connect the hydraulic hose from tool to pump.

**NOTICE** Hydraulic fittings, couplers and hoses are user-supplied and not included with the pump. Installation of a pressure gauge (user-supplied) is strongly recommended.

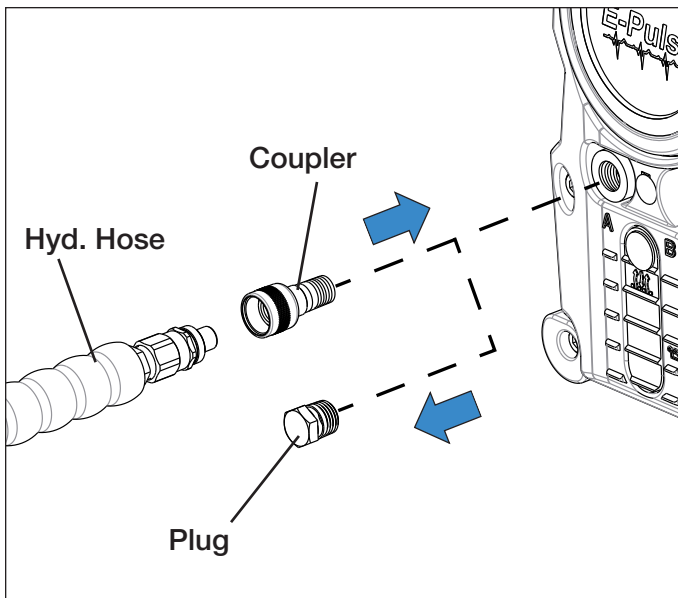

Figure 4, Hydraulic Connections (typical)

### 5.3 Hydraulic Reservoir

For most shipping destinations, the hydraulic reservoir is pre-filled at the factory with Enerpac HF hydraulic oil.

However, as a precaution, always check the oil level before starting the pump. The oil level indicator is located on the pump front panel. Refer to Figure 11 for oil level diagram.

Verify that the oil level is up to the FULL mark. If the oil level is low, add additional oil as required as described in Section 10.3.

### 5.4 Hydraulic Reservoir Air Breather/Filter

The hydraulic reservoir air breather is located just above the oil level indicator. It is composed of a porous stainless steel filter disc and a pre-loaded two-way vent. The vent allows air exchange while maintaining a small positive pressure or vacuum in the reservoir.

Air breather components are factory pre-installed and require no user assembly or adjustment.

An absorbent pad is affixed to the front of the air breather to help prevent oil leakage during shipment. Remove this absorbent pad before using the pump. Wipe off any residual oil with a clean rag.

Note that a small amount of oil may collect on the air breather surface while the pump is being transported. This is normal. However, to prevent possible oil leakage through the air breather, avoid tilting the pump forward while the pump is being operated, transported or stored.

### 5.5 Power Requirements

The EP3104D dump pump is available in a choice of three different electrical power configurations:

- Model EP3104DB is designed to operate at a nominal voltage of 100-120 VAC. This pump version contains a USA style NEMA 5-15 power plug.
- Model EP3104DI is designed to operate at a nominal voltage of 200-250 VAC. This pump version contains a USA style NEMA 6-15 power plug.
- Model EP3104DE is designed to operate at a nominal voltage of 200-250 VAC. This pump version contains a European style “Schuko” power plug.

All configurations are single-phase, 50-60 Hz.

Before connecting electrical power to the pump, be certain that the AC power supply is the proper voltage. Refer to the pump data plate. Also refer to Section 1.3 for important electrical safety information and precautions.



**Failure to follow the electrical safety precautions contained in Section 1.3 of this manual could result in electric shock. Death or serious personal injury could occur.**

## 6.0 FEATURES AND CONTROLS

### 6.1 Carrying Handle

Always use the carrying handle when transporting the pump to its desired location or when it is necessary to reposition the pump while it is in use.

The top of the carrying handle contains a storage pocket for the pendant. The base of the carrying handle contains a storage area for the pendant cable.

A fault code reference diagram is located inside the pendant storage pocket.

**NOTICE** To prevent possible damage, never attempt to carry or reposition the pump by dragging it by the hydraulic hose, AC power cord or pendant cable.

### 6.2 Ventilation System

Air vents are located on the inner edges of the pump front and rear covers. These vents combine with the cooling fins on the sides of the pump housing to help maintain allowable operating temperatures. Before start-up, check that the cooling fins and vents are not covered by dirt or other obstructions.

### 6.3 Pendant

A remote control pendant with a 10 foot [3 m] cable is standard equipment on all models. The back of the pendant housing contains a strong rare earth magnet, allowing the pendant to be positioned against most iron and ferrous metal surfaces.

Pump operation is controlled using the two buttons on the pendant. In addition, the pendant also contains a multi-color LED indicator which communicates the pump status via a series of steady or blinking lights.

#### Pendant LED Indicator (Fig. 5, Item 1)

- Steady green: READY (motor off)
- Blinking green: PUMP ON (motor running)
- Blinking red and/or yellow: Fault code activated (motor off)

The pendant LED indicator will glow steady green approximately 3 seconds after power is connected, indicating that the electronic controls have powered-up and that the pump is ready for use.

**NOTICE** A fault code indicates an abnormal condition that will result in immediate pump motor shutdown. Refer to Section 14.0 for a description of the pump's user-level fault codes.

#### Pendant Buttons (Fig. 5, Items 2 and 3)

- Jog on-off button: Press and hold the *jog on-off* button to start and run the motor, and advance the tool. Release the button to stop the motor and retract the tool.
- Latched on-off button: Press and release the *latched on-off* button to start the motor and advance the tool. Motor will continue running when button is released. Press and release the button again to stop the motor and retract the tool.

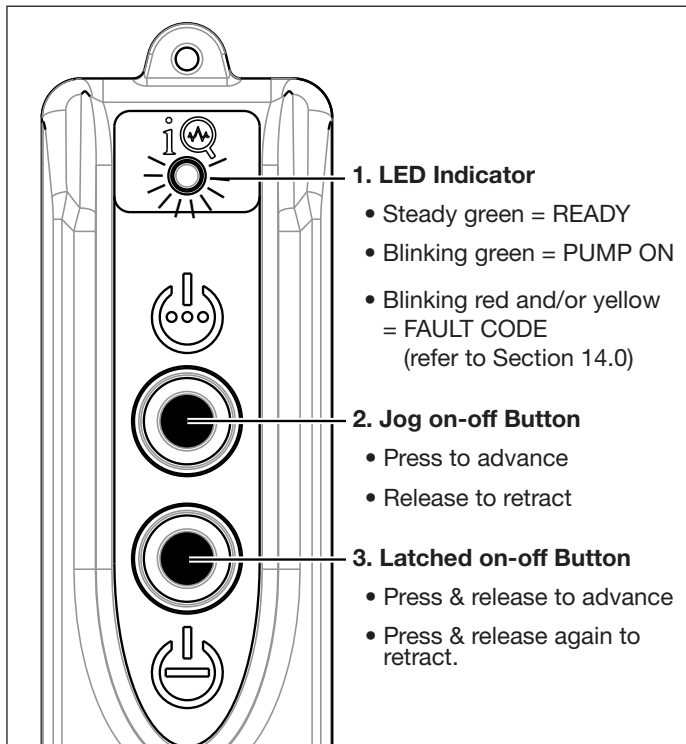

Figure 5, Pendant Features and Controls

**WARNING** Continuously monitor tool operation and be prepared to stop the pump immediately. Never allow the pump to operate in the *latched* mode while it is unattended.

**NOTICE** When in *latched* mode, pump will shut off automatically after 5 minutes if it is not stopped sooner by the operator.

**NOTICE** Monitor the hydraulic reservoir oil level when operating the pump in *latched* mode for a prolonged period of time. Be careful not to allow the reservoir to become completely drained of oil.

#### Pendant Haptic Pulse Feature

- To provide positive confirmation of pump status, the pendant will vibrate haptic pulses as the pendant buttons are depressed and released.
- One haptic pulse indicates that the motor has been turned on. Two haptic pulses indicates the motor has been turned off.
- The pendant will vibrate haptic pulses in conjunction with the flashing LED indicator to indicate when a fault code has been triggered. Refer to Section 14.0 for additional information.

#### 6.4 3-Way, 2-Position Pilot Operated Control Valve

The pump features an internal pilot-operated control valve with “A” Advance and “T” Tank (oil return) positions. The valve operates automatically as the pump motor is started and stopped via the pendant buttons.

- When pump motor is started, hydraulic oil flows from the pump reservoir to the tool plunger.
- When pump motor is stopped, pressure is relieved and hydraulic oil flows from the tool plunger back to the pump reservoir.
- The control valve does not contain a venturi valve. Flow control devices (user-supplied) must be installed in the system if flow metering is desired.
- The pump contains no load holding function or safety locking valve and is NOT designed for lifting or load holding applications. Refer to additional information and precautions contained in Section 7.5 of this manual.

#### 6.5 Variable Speed Control

A rotary knob mounted on the pump rear panel controls the motor speed. See Figure 6.

The adjustable speed range is approximately 25 to 100% of full rated output, or about 600 to 2400 RPM.

- Knob turned fully counterclockwise equals approximately 25% of rated output. This is the lowest possible setting.
- Midpoint setting of knob equals approximately 50% of rated output.
- Knob turned fully clockwise equals 100% full rated output or maximum possible speed as determined by the pump internal controls, based on operating conditions.

#### 6.6 Constant Speed and Constant Power Modes

- When the speed control knob is set between the full counterclockwise (25%) and midpoint (50%) positions, the pump operates in *constant speed mode*. In this mode, the motor speed will *not* automatically increase or decrease to compensate for changes in load. The user can precisely regulate the amount of hydraulic flow and can manually reduce the flow rate, as needed, to provide increased control and slower movement.
- When the speed control knob is set between the mid point (50%) and full clockwise (100%) positions, the pump operates in *constant power mode*. In this mode, the pump motor will run at the set speed until maximum power is delivered. If the load further increases, the motor will automatically reduce speed to maintain peak torque (and hydraulic force) under demanding conditions.

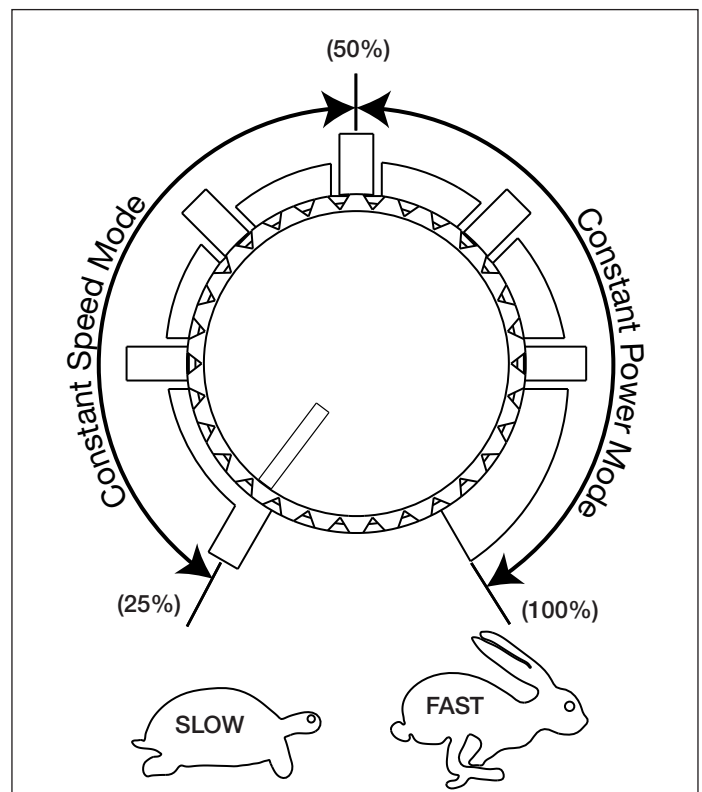

Figure 6, Speed Control Knob

## 7.0 OPERATION

### 7.1 Before Start-up

1. Check the hydraulic oil level. Add oil if necessary. Refer to Sections 10.1 through 10.3.
2. Connect hydraulic hose to pump as described in Section 5.2.
3. Connect pump to a compatible AC power supply of the proper voltage. Input power specifications are listed on the pump data plate and also in Section 2.1.
4. Remove air from system before placing pump into operation. Refer to instructions in Section 7.3.
5. Check all hydraulic hoses, couplers and fittings to be sure they are tight and leak free.

### 7.2 Pump Operating Positions

During operation, the pump can be positioned in the normal horizontal position or vertically on its back cover as shown in Figure 7.

If needed, the pump can also be tilted rearward on an angle, provided that it is adequately supported so that it does not slide, tip over or drop.

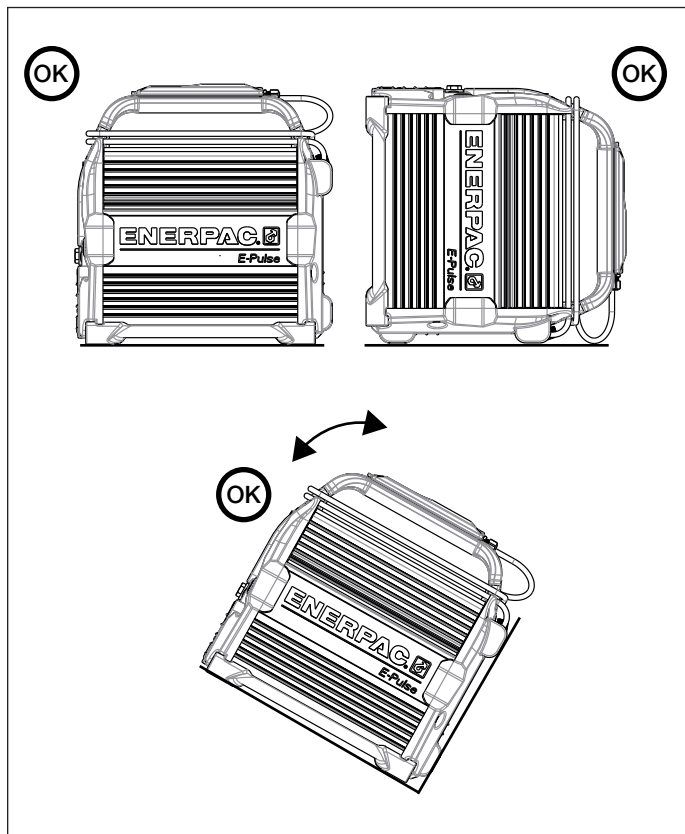

Figure 7, Allowable Pump Operating Positions

To prevent oil leakage and/or damage to pump:

- Never operate the pump while it is positioned on its right or left side, or in an inverted (upside-down) position.
- Never operate the pump in the tilted forward position. Oil leakage and/or damage to pump may result.

See Figure 8.

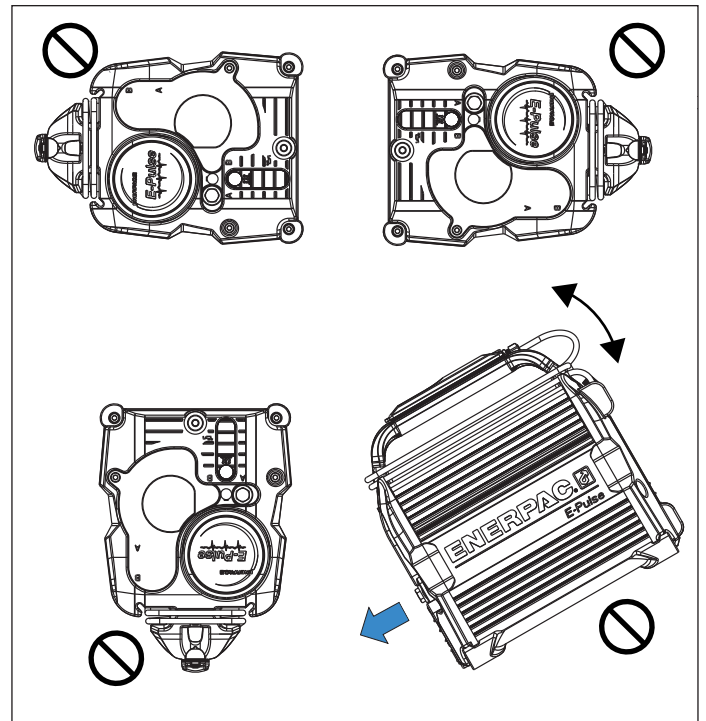

Figure 8, Pump Operating Positions - NOT ALLOWED

### 7.3 Air Removal

When hydraulic components are connected for the first time, air may be trapped in the system. To ensure smooth, safe operation, run the tool through several complete advance-retract cycles before placing the pump into service. Do this with no load on the tool and with the pump positioned higher than the tool.

When the tool advances and retracts smoothly and without hesitation, the air has been vented from the system.

**NOTICE** If tool fails to operate smoothly after being cycled, perform the pump priming/air purging procedure. Refer to Section 10.5.

### 7.4 Operating Precautions



**Failure to observe the following precautions and instructions may result in death or serious personal injury.**

- Keep persons away from the work area during pump operation.
- Continuously monitor the tool being operated. Be prepared to stop the pump immediately if a problem or potentially dangerous situation occurs.
- Whenever possible, the pump speed should be set *before* the pump is operated. Speed adjustments during operation should be minimized so that the operator's complete attention is focused on the lifting or lowering operation being performed.
- Never leave the pump running and unattended while it is being operated in *latched* mode. When in *latched* mode, pump will continue to run until stopped by the user or the 5 minute automatic shut-off timer is activated.
- Because the time for the motor to stop can vary depending on tool characteristics and other factors, the tool may not stop advancing at the exact time the user stops the pump (using the pendant buttons). There may be a small continued movement of the tool while the motor is stopping.
- Avoid continuing to pressurize the tool after it has reached its maximum stroke.

## 7.5 Important Use and Application Information

### **WARNING**

Failure to observe the following precautions and instructions may result in death or serious personal injury.

- The EP3104D dump pump is designed only for use with single-acting hydraulic cutters, punches, pullers and other similar hydraulic tools which DO NOT require a load holding function.
- The EP3104D dump pump is not designed for lifting or load holding applications. The pump does not contain a load holding or safety locking valve. Hydraulic pressure is relieved immediately when pump is turned off or electrical power is disconnected.
- Use of the EP3104D dump pump for lifting and/or load holding applications may result in the load falling on persons working in the area. Death or serious personal injury could result.

### 7.6 Pump Operation

- Start the pump to begin advancing the tool.
- When the tool has advanced the desired amount, stop the pump. Pressure will be relieved and the tool will begin retracting immediately.

### **NOTICE**

- Refer to Sections 6.3 and 6.4 for a detailed description of the pendant controls and control valve functions.
- Additional flow control devices (optional accessories - refer to Enerpac catalog) may be required to more precisely control the rate of tool retraction.
- Single-acting tools not equipped with a return spring may need to be manually retracted after the pump is stopped.
- Pull type hydraulic tools will retract when pump is started and advance when pump is stopped (opposite of typical operation).

## 8.0 RELIEVING HYDRAULIC PRESSURE

Hydraulic pressure is automatically relieved when the pump motor is turned off using the pendant controls or if AC power is disconnected.

As an added precaution, always verify that all hydraulic pressure has been completely relieved before disconnecting hydraulic hoses, loosening hydraulic fittings or performing maintenance or repair procedures. All pressure gauges in the circuit (user-supplied) must indicate zero (0) psi/bar. Hydraulic hose(s) must not be stiff. There must be no other indications of pressure in the system.

In the event of a malfunction, hydraulic pressure trapped within the pump can be relieved manually by turning the relief valve screw fully counterclockwise to its lowest setting. Refer to Section 9.0 for additional relief valve information.

**NOTICE** If the pump does not fully relieve hydraulic pressure when the motor is shut-off, discontinue use and take it to an Enerpac Authorized Service Center for diagnosis and repair.

## 9.0 PRESSURE RELIEF VALVE ADJUSTMENT

### **WARNING**

Maximum pump hydraulic pressure is limited by a mechanical stop to approximately 10,300 to 10,800 psi [710 to 745 bar]. Be certain that the relief valve pressure setting does not exceed the maximum rated pressure of the tool being used. Failure to observe this precaution may result in catastrophic failure of tool and related components. Death or serious personal injury could occur.

The pump contains a user-adjustable pressure relief valve that controls system pressure. This valve is factory set at approximately 10,000 psi [700 bar]. However, the valve setting can be adjusted by the user if needed, as described in the following procedure.

1. Be sure that pump is off and that all hydraulic pressure is completely relieved. Refer to information in Section 8.0.
2. Disconnect the hydraulic hose from the pump "A" port.
3. Install a 0-15,000 psi [0-1035 bar] hydraulic pressure gauge in the pump "A" port. See Figure 9.

**NOTICE** Use only a flat blade screwdriver of appropriate size to adjust the relief valve pressure. The relief valve screw has a stop at the fully clockwise and fully counterclockwise positions. To prevent damage, do not continue to apply force when the screw stops turning.

4. Insert a flat blade screwdriver into the notch above the relief valve access hole. Remove the protective cover. See Figure 10.
5. Insert the screwdriver into the relief valve access hole. Gently engage the screwdriver blade with the slot in the relief valve screw. Use a flashlight if extra light is needed to view the screw.
6. Start and run the pump. Allow pressure to build.

**NOTICE** The pump automatically shifts from first to second stage operation at approximately 3000 psi [207 bar]. To prevent erratic operation and/or pump chatter, avoid setting the relief valve pressure within the range of 2900 to 3100 psi. [200 to 214 bar].

7. To **increase** the relief valve setting: With the pump running and while watching the pressure gauge, SLOWLY turn the relief valve screw clockwise until pressure increases to the desired setting.

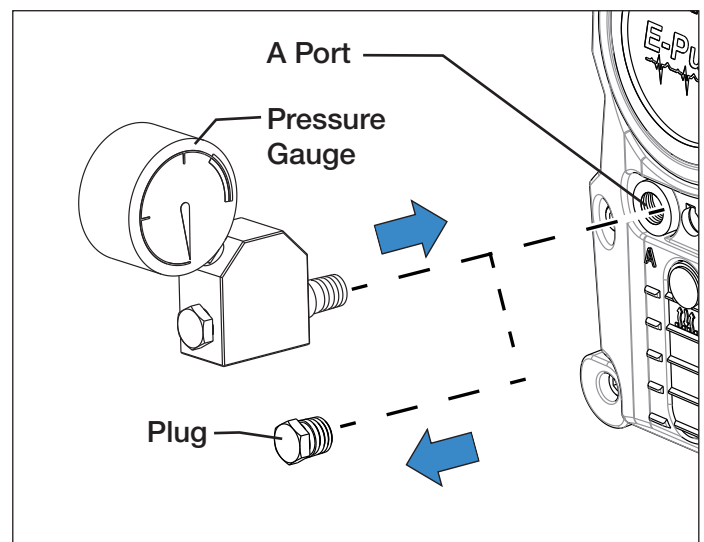
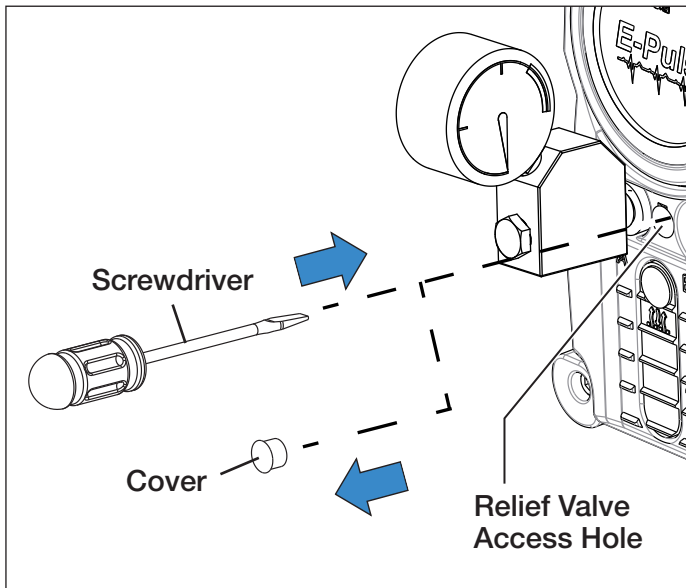

Figure 9, Pressure Gauge Installation



**Figure 10, Pressure Relief Valve Adjustment**

8. To **decrease** the relief valve setting:
  - a. Turn the relief valve screw counter-clockwise one turn. If a very low pressure setting is desired, turn the relief valve screw additional turns until it becomes loose.
  - b. With the pump running and while watching the pressure gauge, **SLOWLY** turn the relief valve screw clockwise until the "A" port pressure increases to the desired setting.
9. When the desired pressure setting is reached, remove the screwdriver.
10. Stop the pump.
11. Check that pressure gauge indicates zero (0) psi/bar.
12. Start the pump again and watch the pressure gauge. Verify that the desired pressure is shown on the gauge.
  - If the pressure setting is correct, continue with steps 13-16.
  - If the pressure setting is **NOT** correct, repeat steps 5 through 12.
13. Stop the pump. Check that pressure gauge indicates zero (0) psi/bar.
14. Remove pressure gauge from the pump "A" port.
15. Reinstall protective cover over the relief valve access hole.
16. Reconnect hydraulic hose to the pump "A" port.

## 10.0 HYDRAULIC SYSTEM MAINTENANCE

### **WARNING**

Failure to observe and comply with the following precautions could result in death or serious personal injury. Property damage could also occur.

- To avoid accidental starting, be certain that the pump AC power cord is disconnected from the electrical outlet before performing any maintenance procedures.
- Be certain that all system hydraulic pressure is completely relieved before performing any maintenance procedures. Refer to information in Section 8.0.

### 10.1 Hydraulic Oil Information

Enerpac HF hydraulic oil (ISO Grade 32) is the recommended oil for all E-Series pumps. This oil is suitable for most applications and working environments.

### **NOTICE**

- Use of oils other than Enerpac HF may result in damage to pump hydraulic components and will void the Enerpac product warranty. Enerpac recommends using only Enerpac HF oil in the E-Series pumps.
- Never mix oils of different viscosities. Mixing oil viscosities may result in damage to pump components and will void the Enerpac product warranty.

### 10.2 Checking the Oil Level

1. Be sure that hydraulic tool is fully retracted.
2. Be certain that pump is stopped and that all hydraulic pressure is fully relieved before continuing this procedure. Refer to Section 8.0.
3. Be sure that the pump is placed on a level surface.
4. Check the oil level indicator. Verify that the oil level is up to the full mark. Refer to Figure 11.
 

If oil level is low: Add oil as described in Section 10.3. Refer to Section 10.1 for oil specifications.

**NOTICE** Be sure that the oil is clean. If the oil has a milky, cloudy or dark appearance, it should be changed immediately as described in Section 10.4.

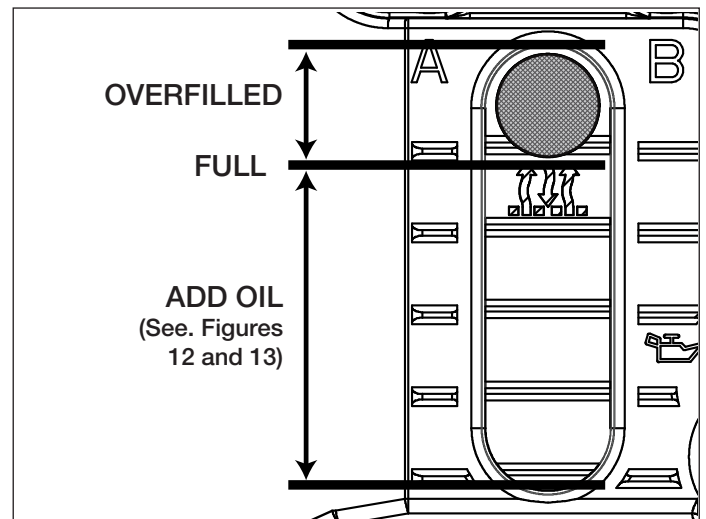

**Figure 11, Oil Level Indicator**

### 10.3 Adding Oil

1. Be sure that hydraulic tool is fully retracted.
2. Be certain that pump is off and that all hydraulic pressure is fully relieved. Refer to Section 8.0 for additional information.
3. Disconnect pump AC power cord from electrical outlet.
4. Disconnect hydraulic hose from pump.
5. With the pump in the normal (horizontal) operating position, check the oil level in the oil level indicator. Use the diagram in Figure 13 to determine the approximate amount of additional oil that must be added.
6. Place the pump on a stable and level work surface, with the front cover facing UP, and the rear cover supported by the work surface. See Figure 12.
7. Using a clean rag, remove any dirt from the area around the hydraulic reservoir drain/fill plug. Remove the drain/fill plug.

#### NOTICE

- Refer to Section 10.1 for oil specifications. Use only new oil poured from a clean container.
  - Always use a funnel when adding oil. To avoid spillage and to ensure that pump internal venting functions properly during filling, funnel neck outer diameter must not exceed 1/2 inch [12 mm] or be less than 1/4" [6.3 mm]. Refer to Figure 12.
  - Add oil only with the pump front panel facing up, and with the pump positioned on a level surface.
  - When the maximum oil level is achieved, an internal overflow tube will direct oil to the concentric vents located around the oil drain/fill port. Stop adding oil immediately when oil begins flowing from these vents. Wipe up any spilled oil with a clean cloth.
  - Do not tilt or reposition the pump when adding oil. Overfilling and oil leakage will result.
  - Remove and dispose of any spilled oil in accordance with all applicable laws and regulations.
8. Slowly pour new oil into the reservoir through the oil drain/fill port. Continue pouring until excess oil begins flowing from the concentric vents around the oil drain/fill port. This indicates that the reservoir is full.
  9. After adding oil, wipe the oil drain/fill plug with a clean rag and reinstall it. Torque to 13-16 ft-lb [17.6-21.7 Nm].
  10. Place the pump in the normal (horizontal) operating position, with the carrying handle facing up.

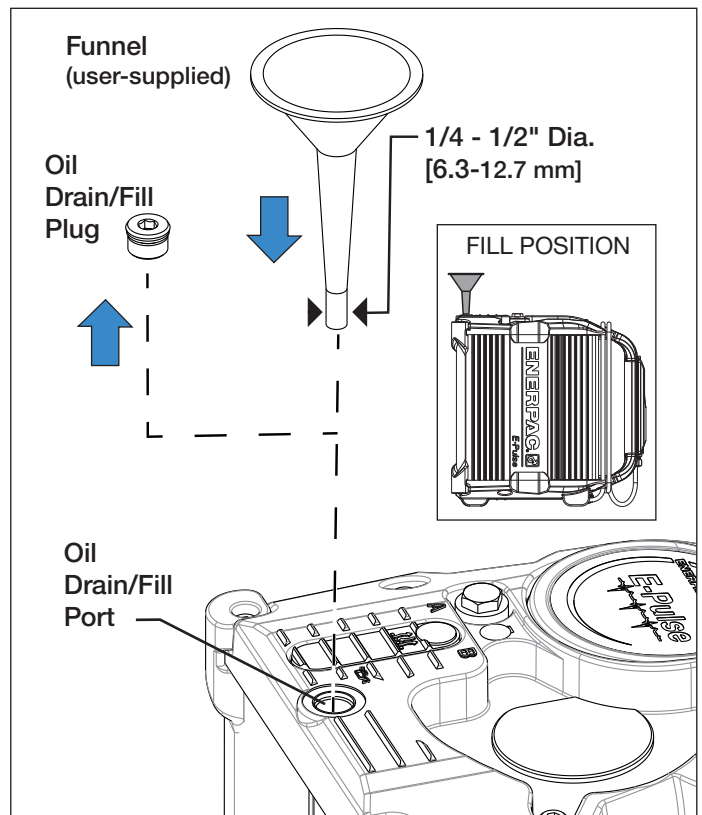

Figure 12, Adding Oil

11. Check the oil level indicator. Verify that the oil level is up to the FULL mark and that the reservoir is not overfilled. Refer to Figure 11.

#### NOTICE

- If the pump was previously operated with a very low oil level or run until the reservoir was emptied, perform the pump priming/air purging procedure before using the pump. Refer to Section 10.5.
- If reservoir is accidentally overfilled (oil level above full mark), drain excess oil before using the pump. Oil may leak from the reservoir air breather if overfilling occurs.

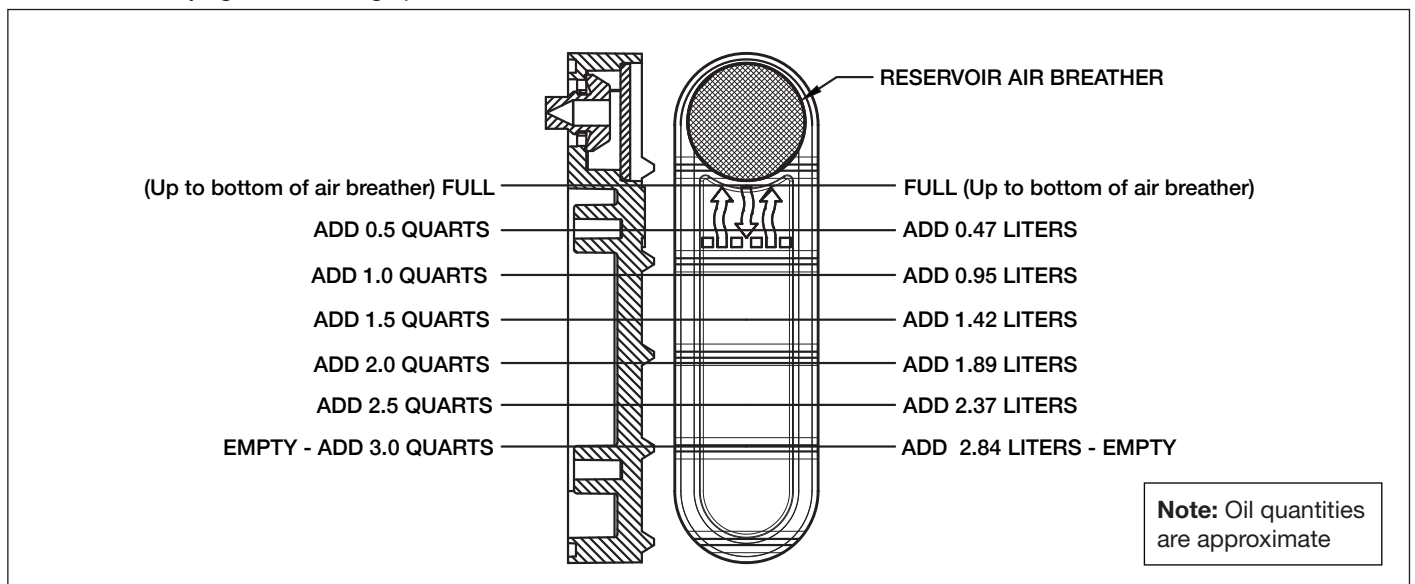

Figure 13, Reservoir Oil Fill Guide

## 10.4 Oil Change

1. Be sure that hydraulic tool is fully retracted.
2. Be certain that pump is off and that all hydraulic pressure is fully relieved. Refer to Section 8.0 for additional information.
3. Disconnect pump AC power cord from electrical outlet.
4. Disconnect hydraulic hose from pump.
5. Place the pump on a stable and level work surface.
6. Place a suitable pan or container of appropriate capacity under the oil drain/fill plug.

### NOTICE

- Pump total oil capacity (including reservoir and pump element housing) is approximately 1.14 gallons [4.33 liters]. Be sure the pan or container used is large enough to hold all the drained oil.
  - DO NOT operate the pump motor to drain the oil. Serious permanent damage to pump internal components may result. Such damage is not covered under warranty.
  - Remove and dispose of used hydraulic oil in accordance with all applicable laws and regulations.
7. Remove the oil drain/fill plug. Allow all used oil to drain completely from the reservoir into the pan or container. It may be necessary to tilt the pump slightly forward to drain all the used oil.
  8. Refill the reservoir with new hydraulic oil as described in Section 10.3.
  9. Perform the pump priming/air purging procedure. Refer to the instructions in Section 10.5.

## 10.5 Pump Priming/Air Purging

Always perform the pump priming/air purging procedure after completing an oil change.

This procedure should also be performed if the pump reservoir has been refilled with oil after being accidentally run dry (with little or no oil remaining in reservoir).

**NOTICE** The pump will typically make a slapping, sloshing or whirring noise if air pockets are present inside the pump element housing. If the pump is not primed, there will be either very little noise or an erratic sounding noise.

Perform the pump priming/air purging procedure as described in the following steps:

1. Be certain that pump is off and that all hydraulic pressure is fully relieved. Refer to Section 8.0 for additional information.
2. Disconnect pump AC power cord from electrical outlet.
3. Disconnect hydraulic hose from pump.
4. Install a 0-15,000 psi [0-1034 bar] hydraulic pressure gauge in the pump "A" port.
5. Reconnect pump AC power cord to electrical outlet.
6. Start and run the pump for approximately 10 seconds at a pressure setting of 3250 psi [225 bar] or higher. This will remove any air trapped in the pump element housing.
7. Stop the pump. Verify that hydraulic pressure gauge indicates zero (0) psi/bar.
8. Repeat steps 6 and 7 as needed (typically 2-3 times).
9. Reconnect hydraulic hose. Verify that pump operates without making abnormal noises and that tool movement is smooth.

## 11.0 CLEANING AND INSPECTION

- Periodically clean the cooling fins on the pump side surfaces to remove any accumulated dust or dirt.
- Remove any dust or dirt from the pump front and rear covers and the pump top and bottom surfaces. Be sure that all four air vents are unobstructed.
- Periodically wipe the air breather/filter surface with a clean rag to remove any loose dirt or oil sediment. The air breather/filter must remain unobstructed to allow proper reservoir venting.
- Be sure that pendant and controls are free of dust or dirt.
- To prevent contamination, always remove any dirt from around the oil drain/fill plug before removing it. Wipe the drain/fill plug with a clean rag before reinstalling it.
- Check for loose, missing or damaged parts. Make repairs as required before returning the pump to use.

## 12.0 STORAGE

Store the pump in a clean, dry and secure location.

To prevent possible damage to pump components, storage area ambient temperature must not be less than -22°F [-30°C] and must not exceed +149°F. [+65°C].

## 13.0 TROUBLESHOOTING

The Troubleshooting Guide (Table 1) is intended as an aid to help diagnose and correct various possible problems that may occur.

For repair service, contact your nearest Enerpac Authorized Service Center. Only an Enerpac Authorized Service Center should be permitted to service the pump and its components.

### WARNING

**Failure to observe and comply with the following precautions could result in death or serious personal injury. Property damage could also occur.**

- Never tighten or loosen hydraulic fittings while the pump hydraulic system or connected components are pressurized. Escaping oil under pressure can penetrate the skin, causing serious personal injury.
- Keep hands, fingers and other body parts clear of pinch points and moving parts when observing operation during troubleshooting.
- To prevent accidental start-up of pump during servicing, always disconnect the pump from electrical power source before performing any maintenance or repair procedures.



Table 1 - Troubleshooting Guide		
Problem	Possible Cause	Action
1. Pump will not start.	a. No power.	Be sure that the pump AC power cord is connected to the electrical outlet.
	b. Pump fault triggered.	Refer to Table 2, Pump Fault Codes, for additional information.
2. Pump stops under load.	a. Pump fault triggered.	Refer to Table 2, Pump Fault Codes, for additional information.
	b. Pump bypass valve out of adjustment or malfunctioning.	Contact Enerpac Authorized Service Center.
	c. Pump jammed due to obstruction.	Contact Enerpac Authorized Service Center.
	d. Internal damage to pump and/or motor.	Contact Enerpac Authorized Service Center.
3. Pump fails to build pressure or builds less than full pressure.	a. Low oil level.	Add oil to reservoir as required. Refer to Section 10.3. Follow priming procedure in Section 10.5 if pump reservoir was emptied during operation or while pump was being serviced.
	b. Relief valve open or set too low.	Raise relief valve pressure setting. Refer to Section 9.0.
	c. Oil needs changing.	Completely drain and refill reservoir per instructions in Section 10.4. <b>NOTICE</b> Use only Enerpac HF hydraulic oil. Use of other oils may result in damage to pump components and will void the Enerpac product warranty.
	d. External system leak.	Repair or replace components as required.
	e. Pump oil intake suction filter is dirty.	Contact Enerpac Authorized Service Center.
	f. Pump bypass valve out of adjustment or malfunctioning.	Contact Enerpac Authorized Service Center.
	g. Pump internal leakage.	Contact Enerpac Authorized Service Center.
	h. Pump seals worn or damaged.	Contact Enerpac Authorized Service Center.
	i. Internal damage to pump and/or motor.	Contact Enerpac Authorized Service Center.
4. Low fluid output.	a. Pump speed too low.	Increase pump speed by adjusting knob at rear of pump.
	b. AC line voltage too low.	Low AC line voltage may result in lower motor speeds and reduced hydraulic output.
	c. External system leak.	Repair or replace leaking components as required.
	d. Pump needs priming.	Refer to Section 10.5 for priming procedure.
	e. Pump bypass valve malfunction.	Contact Enerpac Authorized Service Center.
	f. Pump oil intake suction filter is dirty.	Contact Enerpac Authorized Service Center.
	g. Pump internal leakage.	Contact Enerpac Authorized Service Center.
	h. Pump seals worn or damaged.	Contact Enerpac Authorized Service Center.
	i. Internal damage to pump and/or motor.	Contact Enerpac Authorized Service Center.
5. Pump builds to full pressure, but hydraulic tool does not advance or advances erratically.	a. Low oil level.	Add oil to reservoir as required. Refer to Section 10.3.
	b. Pump needs priming.	Refer to Section 10.5 for priming procedure.
	c. Load greater than hydraulic tool capacity at full pressure.	Reduce load or use a tool of larger capacity.
	d. Flow is restricted or blocked.	Check hydraulic couplers for full engagement. Check hose for blockage or kinks.
	e. Control valve malfunction.	Contact Enerpac Authorized Service Center.
	f. Internal damage to pump.	Contact Enerpac Authorized Service Center.



(Continued on next page)

Table 1 - Troubleshooting Guide (Continued)		
Problem	Possible Cause	Action
6. Hydraulic cylinder or tool retracts erratically or does not fully retract.	a. Flow is restricted or blocked.	Check hydraulic couplers for full engagement. Check hose for blockage or kinks.
	b. Single-acting cylinder or tool not equipped with a return spring.	Some single-acting tools not equipped with a return spring may need to be manually retracted after pressure is relieved.
	c. Control valve malfunction.	Contact Enerpac Authorized Service Center.
7. Noisy pump operation.	a. Pump needs priming.	Refer to Section 10.5 for priming procedure.
	b. High oil flow over relief valve.	The user-adjustable relief valve may create a high pitched noise when relieving high oil flow.
	c. Relief pressure setting too close to pump bypass valve setting.	Avoid setting relief valve at the pump bypass setting of 3000 psi [207 bar] whenever possible
	d. Damaged and/or loose components inside pump, vibrating and/or making contact.	Contact Enerpac Authorized Service Center.
	e. Pump elements worn or damaged.	Contact Enerpac Authorized Service Center.
	f. Motor worn or damaged.	Contact Enerpac Authorized Service Center.
8. Pump runs hot.	a. Low oil level.	Check oil level with pump stopped and cylinder or tool fully retracted. Add oil if low.
	b. Flow is restricted or blocked.	Check hydraulic couplers for full engagement. Check hydraulic hose(s) for blockage or kinks.
	c. Oil flowing over the relief valve for long periods of time.	Reduce the amount of motor running time while oil is flowing over the relief valve.
	d. Pump air vents and/or cooling fins covered with dirt.	Remove any dirt from pump air vents and cooling fins. Be sure that all four air vents are unobstructed.
	e. Pump speed too fast.	Reduce pump speed.
	f. Low voltage.	Check AC line voltage. Pump can operate during a limited low voltage condition but overheating may result.
9. Pendant LED indicator flashes randomly at start-up. Pump does not operate when pendant buttons are pressed.	a. Service center diagnostic mode activated.	<b>NOTICE</b> The service center diagnostic mode can be accidentally activated if the pendant jog button is pressed down while the pump AC power cord is being plugged into the electrical outlet.  If the pendant LED indicator blinks randomly yellow or red/yellow, it indicates that the pump may be in diagnostic mode.  To exit diagnostic mode, disconnect and reconnect AC electric power. Be sure no pendant buttons are being pressed as the pump AC power cord is being plugged into the electrical outlet.  The pendant LED indicator should appear solid green approximately 3 seconds after power has been reconnected. This indicates that the pump is in normal operational mode.
	b. Pump electrical and/or mechanical problems.	Contact Enerpac Authorized Service Center.

## 14.0 PUMP FAULT CODES (user-level)

Pump fault codes are displayed by the pendant LED indicator.

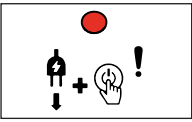
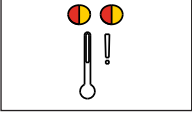
- Refer to Table 2 for pump fault code information.
- See Figure 5 for location of pendant LED indicator.

Table 2 - Pump Fault Codes (user-level)			
Fault	Pendant LED Indicator	Cause	Action
<p><b>BUTTON FAULT</b></p> 	<p>1 red blink followed by a 1 second pause. Sequence repeats until problem is corrected.</p>	<p>Pendant buttons pressed while AC power cord is connected to outlet.</p>	<ul style="list-style-type: none"> <li>• Disconnect power.</li> <li>• Ensure that pendant buttons are not being pressed.</li> <li>• Reconnect power and try to start pump again.</li> <li>• If problem persists, contact Enerpac Authorized Service Center.</li> </ul>
		<p>Damage to pendant and/or cable wiring.</p>	<p>Check pendant and pendant cable for obvious signs of damage or wear. Contact Enerpac Authorized Service Center if repairs are needed.</p>
<p><b>TEMPERATURE FAULT</b></p> 	<p>2 fast red/yellow blinks followed by a 1 second pause. Sequence repeats until pump cools to an acceptable temperature.</p>	<p>Motor, electrical or internal ambient temperature too high.</p>	<p>Allow time for pump temperature to decrease (as required).</p>
<p><b>VOLTAGE FAULT</b></p> 	<p>3 yellow blinks followed by a 1 second pause. Sequence repeats until problem is corrected.</p>	<p>Voltage above or below acceptable voltage range for your pump model.</p>	<p>Check AC power supply for correct voltage.</p>
<p><b>SERVICE REQUIRED FAULT</b></p> 	<p>4 red blinks followed by a 1 second pause. Sequence repeats until problem is corrected.</p>	<p>Mechanical or electrical failure.</p>	<p>Additional diagnostic procedures required to determine problem. Contact Enerpac Authorized Service Center.</p>
<p><b>Notes:</b></p> <ul style="list-style-type: none"> <li>• The pendant LED indicator will continue to repeat the fault code until the problem is corrected. A 1 second pause will occur in between the repeated fault codes.</li> <li>• Pendant haptic pulses (vibration) will occur simultaneously when the LED indicator begins flashing a fault code. After the LED indicator has repeated the fault code 3 times, the haptic pulses will stop.</li> </ul>			

**ENERPAC**   
<http://www.enerpac.com>