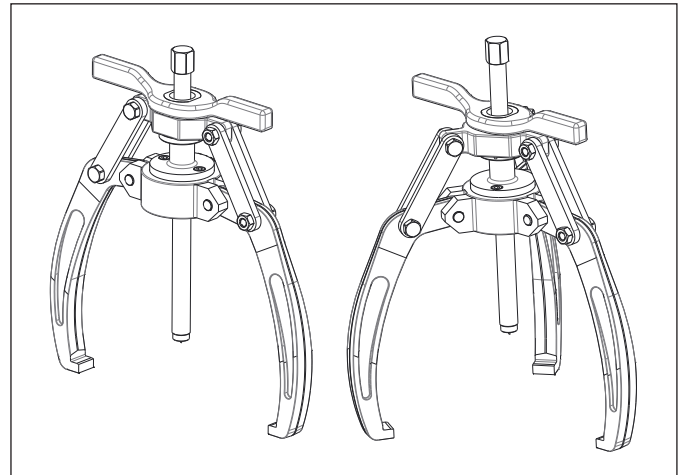

Table of Contents:

1.0 IMPORTANT RECEIVING INSTRUCTIONS	1
2.0 SAFETY.....	1
3.0 CONFORMANCE TO NATIONAL AND INTERNATIONAL STANDARDS.....	2
4.0 PRODUCT DESCRIPTION	2
5.0 SETUP AND ASSEMBLY	2
6.0 OPERATION.....	3
7.0 INSPECTION, MAINTENANCE AND STORAGE	5
8.0 TROUBLESHOOTING	5
9.0 PRODUCT DATA.....	6



1.0 IMPORTANT RECEIVING INSTRUCTIONS

Visually inspect all components for shipping damage. Shipping damage is not covered by warranty. If shipping damage is found, notify carrier at once. The carrier is responsible for all repair and replacement costs resulting from damage in shipment.

2.0 SAFETY

2.1 Introduction

Read all instructions carefully. Follow all recommended safety precautions to avoid personal injury as well as damage to the product and/or damage to other property. Enerpac cannot be responsible for any damage or injury from unsafe use, lack of maintenance or incorrect operation. Do not remove warning labels, tags, or decals. In the event any questions or concerns arise, contact Enerpac or your local Enerpac distributor for clarification.

If you have never been trained on high force tool safety, consult your distributor or service center for information about an Enerpac safety course.

This manual follows a system of safety alert symbols, signal words and safety messages to warn the user of specific hazards. Failure to comply with these warnings could result in death or serious personal injury, as well as damage to the equipment or other property.



The Safety Alert Symbol appears throughout this manual. It is used to alert you to potential physical injury hazards. Pay close attention to Safety Alert Symbols and obey all safety messages that follow this symbol to avoid the possibility of death or serious personal injury.

Safety Alert Symbols are used in conjunction with certain Signal Words that call attention to safety messages or property damage messages and designate a degree or level of hazard seriousness. The Signal Words used in this manual are WARNING, CAUTION and NOTICE.

WARNING Indicates a hazardous situation that, if not avoided, could result in death or serious personal injury.

CAUTION Indicates a hazardous situation that, if not avoided, could result in minor or moderate personal injury.

NOTICE Indicates information considered important, but not hazard related (e.g. messages relating to property damage). Please note that the Safety Alert Symbol will not be used with this signal word.

2.2 Safety Precautions - Mechanical Lock Grip Pullers



Failure to observe and comply with the following precautions could result in death or serious personal injury. Property damage could also occur.

- Read and completely understand the safety precautions and instructions in this manual before operating the puller or preparing it for use.
- Wear appropriate personal protective equipment (PPE) such as safety glasses and face shield. The operator must take precautions against injury due to flying debris caused by possible failure of the tool or workpiece.
- During operation, keep hands and fingers away from the work area to avoid personal injury.
- Know the puller rated capacity before beginning any work.
- Do not use the puller in circumstances where a sudden release of mechanical force could result in loss of balance, causing damage or injury.
- Never attempt to pry the puller by inserting tools or other objects between the jaws. This may cause spindle damage.
- It is impossible to predict the exact force needed for every pulling situation. The amount of press fit and force of removal can vary greatly between jobs. Set-up requirements along with the size, shape and condition of the parts being pulled are variables which must be considered. Study each pulling application before you select your puller.

- Do not overload equipment. Use the correct size puller for your application. If you have applied significant force, and the part still will not move, then use a larger capacity puller. Use of sledge hammers to assist in removing components is not recommended.
- Do not overtighten the spindle. Stop tightening if the spindle bends, or if deformation of the jaws occurs.
- Do not use the puller if threads on the spindle and/or body are damaged or worn. Do not use the puller if the spindle is bent.
- Apply force gradually. Align puller jaws as required. Be sure the setup is rigid and that puller is square with the work.
- Make sure that all puller components are protected from external sources of damage, such as excessive heat, flame, moving machine parts, sharp edges and corrosive chemicals.
- Always perform a visual inspection of the puller before placing it into operation. If any problems are found, do not use the puller. Have the equipment repaired and tested before it is returned to service.
- Never use a puller that is damaged, altered or in need of repair.
- Always be sure that the spindle is loosened before performing any puller adjustment or repair procedures. Never service the puller while it is installed and under tension.
- Always read, understand and follow all safety precautions and instructions, including those that are contained within the procedures of this manual.



Failure to observe and comply with the following precaution could result in minor or moderate personal injury. Property damage could also occur.

- Immediately replace worn or damaged parts with genuine Enerpac parts. Enerpac parts are designed to fit properly and to withstand high loads. Non-Enerpac parts may break or cause the product to malfunction.



- High force tool equipment must only be serviced by a qualified technician. For repair service, contact the Enerpac Authorized Service Center in your area.

3.0 CONFORMANCE TO NATIONAL AND INTERNATIONAL STANDARDS

CE Enerpac declares that this product has been tested and conforms to applicable standards and is compatible with all CE Requirements. A copy of an EU Declaration of Incorporation is enclosed with each shipment of this product.

4.0 PRODUCT DESCRIPTION

The LGM-Series Lock Grip Puller can be used to remove gears, bearings, pulleys and other similar shaft mounted parts.

The puller's self centering closing system means that all jaws move at the same time, reducing the chance of damage to the puller components and to the item being removed.

The LGM-Series Lock Grip Pullers feature a hand operated adjustment handle which allows quick and precise positioning of the jaw tips on the workpiece.

Many different models are available to meet the needs of a broad range of applications. Refer to the documentation provided with your shipment for model numbers and additional product data.

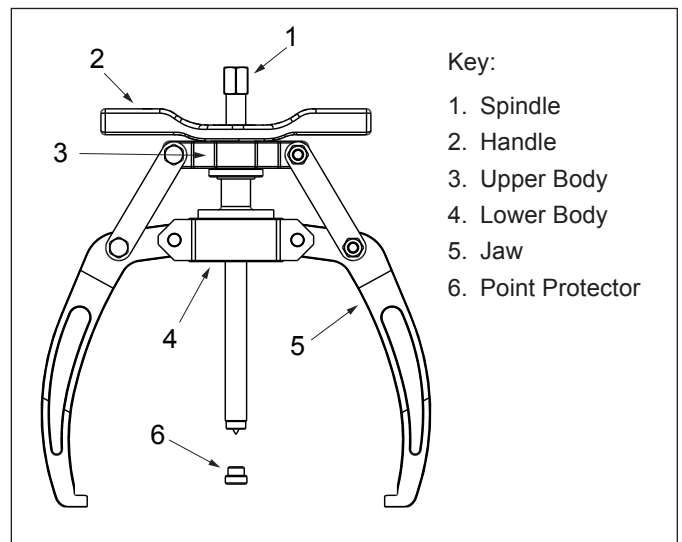

Figure 1, Features and Major Components

5.0 SETUP AND ASSEMBLY

5.1 Handling Large Pullers

- If needed, use a crane and slings of suitable rated capacity to lift and unload the puller.
- Consider the weight of the complete puller including puller body, spindle and jaws when lifting and handling.
- If needed, support and reposition the puller with slings so that it can be used horizontally. When repositioning the puller from the horizontal to the vertical position, incline the puller slowly and carefully.

5.2 Configurations

Model numbers beginning with "LGM2" are two-jaw grip pullers. Model numbers beginning with "LGM3" are three-jaw grip pullers.

5.3 Spindle and Point Protector

The LGM series pullers **MUST** be used with a point protector if the shaft end does not contain a drilled center hole. See Figure 2.

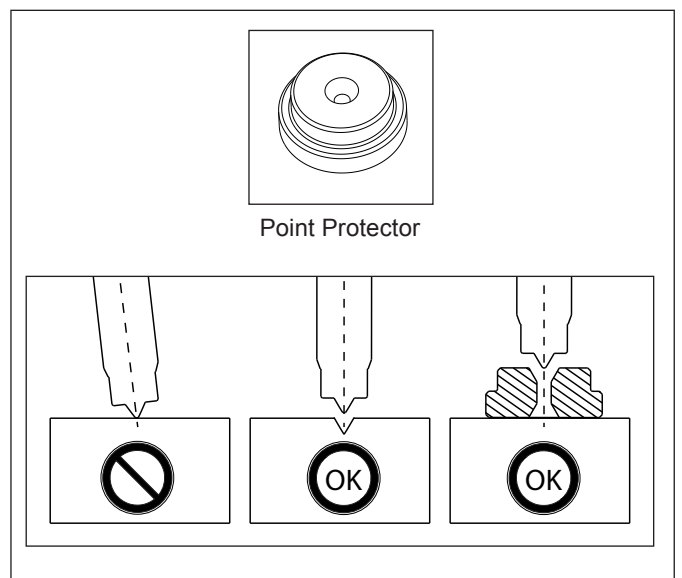

Figure 2, Point Protector

The point protector must be placed on the work surface and aligned with the spindle so that the spindle engages with the point protector during operation.

5.4 Jaw and Spindle Position

- When installing the puller on the workpiece, refer to the maximum reach and spread dimensions contained in Figure 6. Following these important guidelines will reduce the amount of jaw and spindle deflection in the event of great force.
- As the spindle is turned in the clockwise direction, it protrudes an increased distance below the puller body. The length of the spindle that is under load increases. When necessary, use a spacer of appropriate thickness to decrease the portion of the spindle that is under load.

6.0 OPERATION

6.1 General Puller Use Instructions

- Be sure that the puller spindle is cleaned and greased before use.
- Be sure that the jaws are properly centered on the pulley or other item to be removed.
- Work slowly when operating the puller in order to prevent any sudden or unexpected displacement of parts being removed.
- Never strike the spindle with a hammer or any other object.

6.2 Puller Installation and Operation

WARNING Before operating any high force tool equipment, it is mandatory that the operator has a full understanding of all instructions and safety precautions included in this manual, and of all applicable local safety regulations and laws. If there are any questions or concerns, contact the Enerpac Technical Service Department or your local Enerpac distributor.

1. Rotate the spindle to adjust the spindle height up or down. Rotate the handle to increase or decrease the jaw opening. Open jaws and retract spindle sufficiently to place it over the workpiece. Refer to Figure 3, views 1 through 4, during the following steps.

CAUTION The handle threads do not have a stop. Be careful not to fully unscrew the handle when adjusting the jaw opening. Puller jaws will loosen and open fully if threads become disengaged.

2. Place the puller on the workpiece. Position the jaws around the part to be removed and align the spindle point with the center of the shaft.

NOTICE If the end of the shaft is flat, install the point protector between the shaft end and the spindle point. Refer to Section 5.3.

3. Rotate handle clockwise until jaws securely grip the circumference of the shaft. Rotate spindle clockwise by hand until the bottom of the spindle contacts the recessed area of the shaft or the point protector (if used).

NOTICE The spindle and the jaws must engage the workpiece, and achieve at least the minimum reach and spread indicated in figure 6. If additional reach is required, a spacer may be applied. place an appropriately sized spacer between the point protector and the workpiece during step 3.

4. Using a suitable wrench, slowly turn the spindle to apply force, continuing until the part is removed.

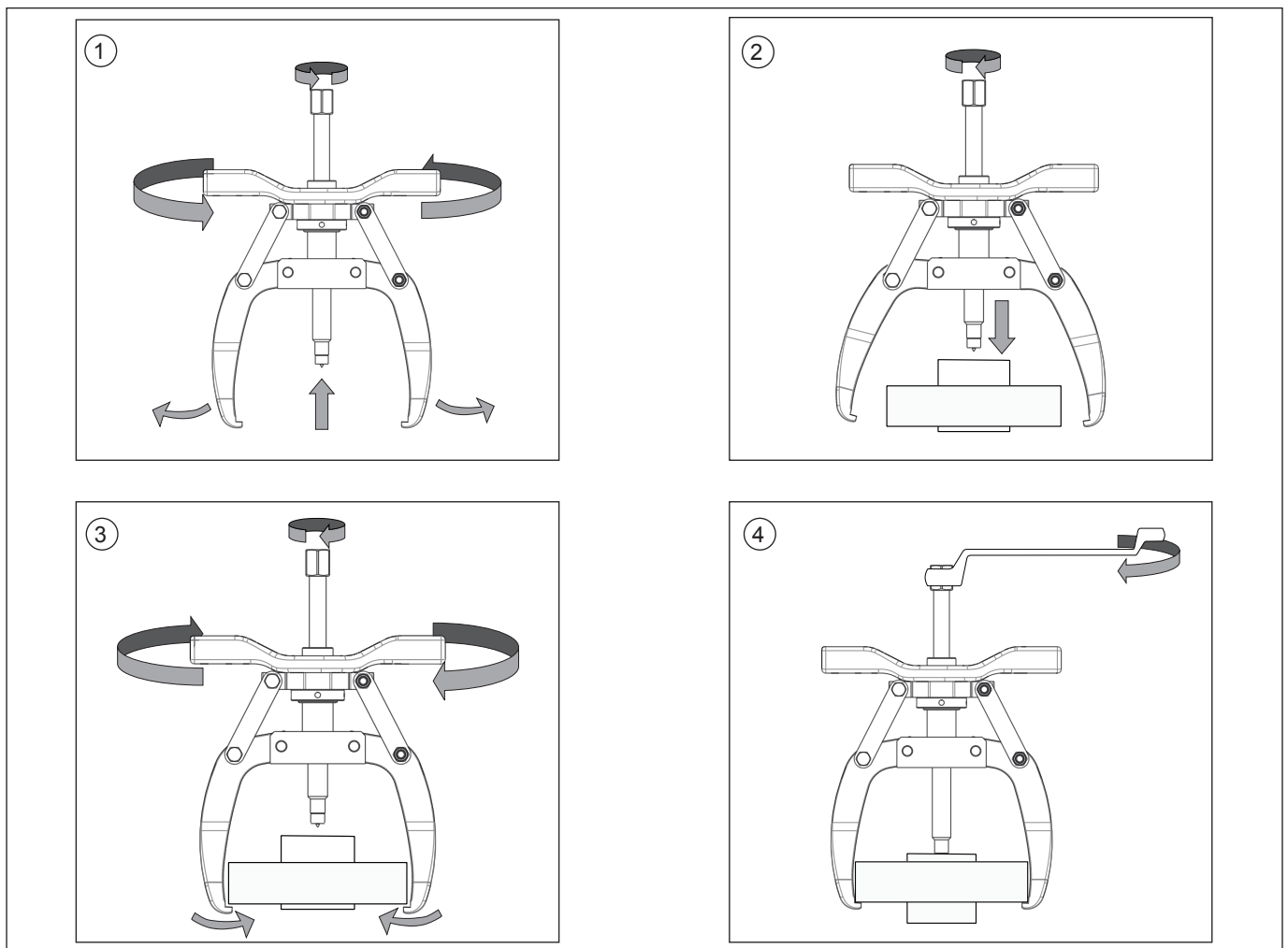

Figure 3, Puller Installation Steps

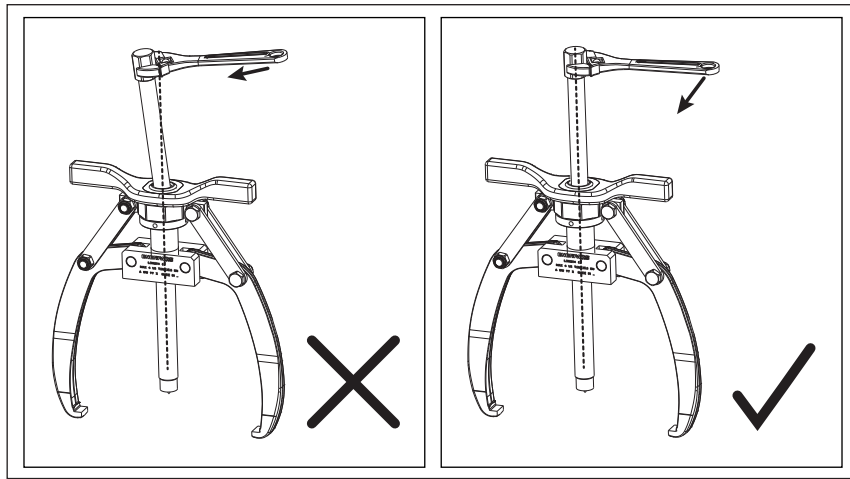

Figure 4, Spindle Bending Prevention

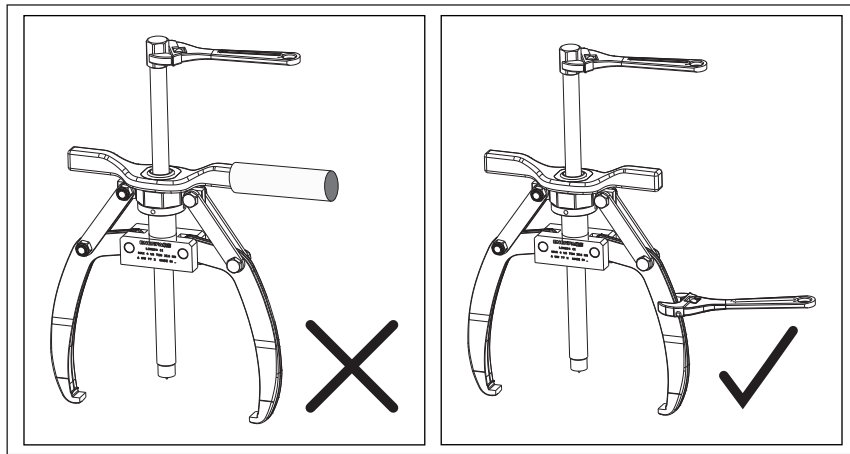

Figure 5, Puller Holding Recommendation

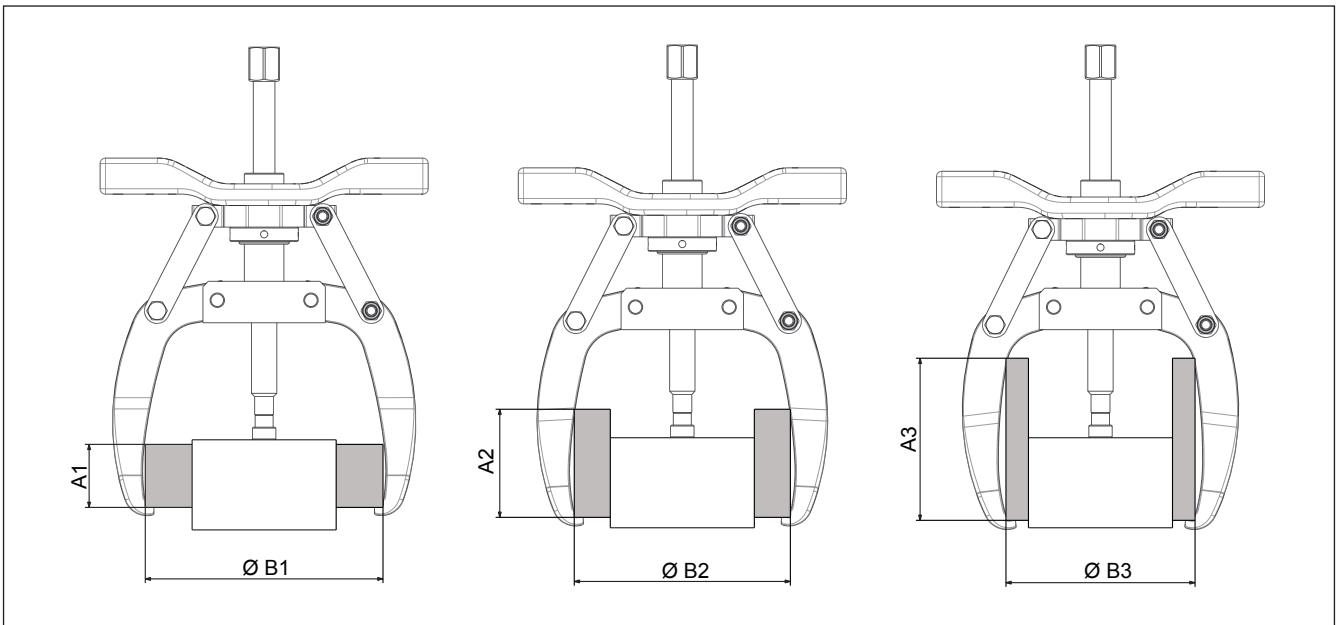

Figure 6, Puller Maximum Reach and Spread

Puller Model Number	A1		B1		A2		B2		A3		B3	
	mm	in	mm	in	mm	in	mm	in	mm	in	mm	in
LGM203 / LGM305	35	1.38	132	5.20	60	2.36	120	4.72	90	3.54	105	4.13
LGM204 / LGM306	60	2.36	186	7.32	90	3.54	165	6.50	140	5.51	125	4.92
LGM207 / LGM308	55	2.17	260	10.24	105	4.13	220	8.66	165	6.50	180	7.09
LGM211 / LGM313	95	3.74	300	11.81	135	5.31	255	10.04	195	7.68	205	8.07

⚠ WARNING

Limit applied torque as required to ensure safe operation. Apply force using a hand wrench. NEVER use a powered wrench to turn the spindle. Serious personal injury or death may result if these precautions are not observed.

During operation, continuously monitor the puller for indications of deformation. If the spindle bends or any jaw deformation is noticed, stop tightening the spindle immediately. See Figure 7.

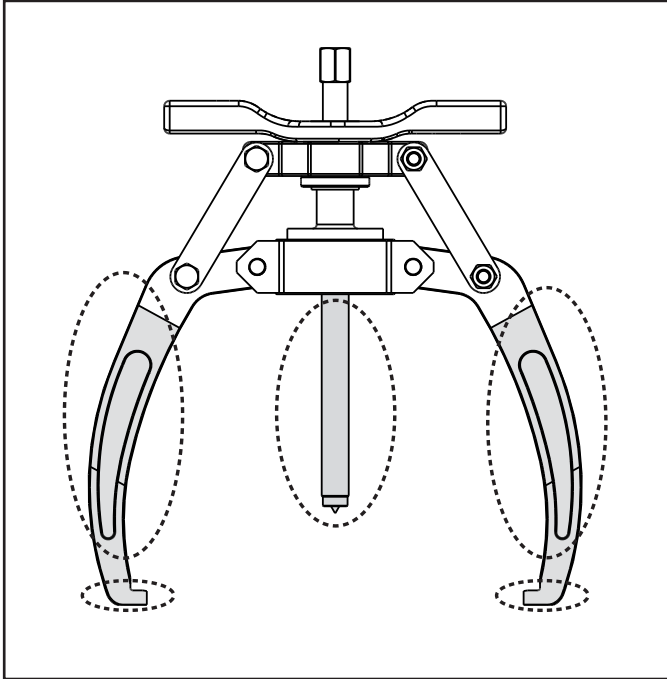

Figure 7, Checking for Deformation

Pull the wrench and turn the spindle in a straight arc. To prevent bending the spindle or placing excessive strain on puller components, do not apply lateral force when rotating the spindle. See Figure 4.

The handle is not designed as a blocking or holding device and may break if excessive force is applied.

Do not use the handle to prevent the puller from moving. Never add an extension or grip onto the handle. If it is necessary to hold the puller in position when applying force to the spindle, grasp one of the jaws with a second wrench. This will help prevent unwanted puller movement. See Figure 5.

7.0 INSPECTION, MAINTENANCE AND STORAGE

Maintenance is required when wear or damage occurs. Periodically inspect all components to detect any problem requiring maintenance or service.

- Periodically check the puller for loose, bent, worn or damaged components. Tighten or replace any such components immediately.
- Keep the puller free of dust and dirt.
- Keep the puller in good condition. Clean and lubricate the puller's spindle, from top of threaded area to tip, to ensure good operation and long life.
- Store the puller in a clean, dry and secure location.
- If the puller requires repairs, refer to the Enerpac website for the repair parts sheet applicable to your puller model.

The puller must only be serviced by a qualified technician. For repair service, contact the Enerpac Authorized Service Center in your area.

8.0 TROUBLESHOOTING

Refer to the troubleshooting guide when diagnosing puller operational problems. Please note that the troubleshooting guide is not all-inclusive, and should be considered only as an aid to help diagnose the most commonly anticipated problems.

Troubleshooting Guide, LGM-Series Sync Grip Mechanical Pullers		
Symptom	Possible Cause	Solution
Jaws do not move freely or are difficult to move.	Self-centering mechanism corroded or seized.	Inspect self-centering mechanism. If corroded or seized, apply penetrating oil. Dismantle and clean mechanism as required.
One jaw moves independently.	Self-centering strap damaged or broken.	Replace self-centering strap. Replace complete self-centering mechanism if needed.
Spindle will not turn or requires excessive effort to turn.	Corroded threads on spindle or lower body.	If parts are seized, apply penetrating oil. Inspect threads on spindle and lower body. Dismantle and clean components as required.
	Worn or damaged threads.	Replace spindle and/or lower body as required. Do not use puller if threads are worn or damaged.
	Spindle is bent.	Replace spindle. Do not use puller if spindle is bent.

9.0 PRODUCT DATA

9.1 General Specifications and Dimensions

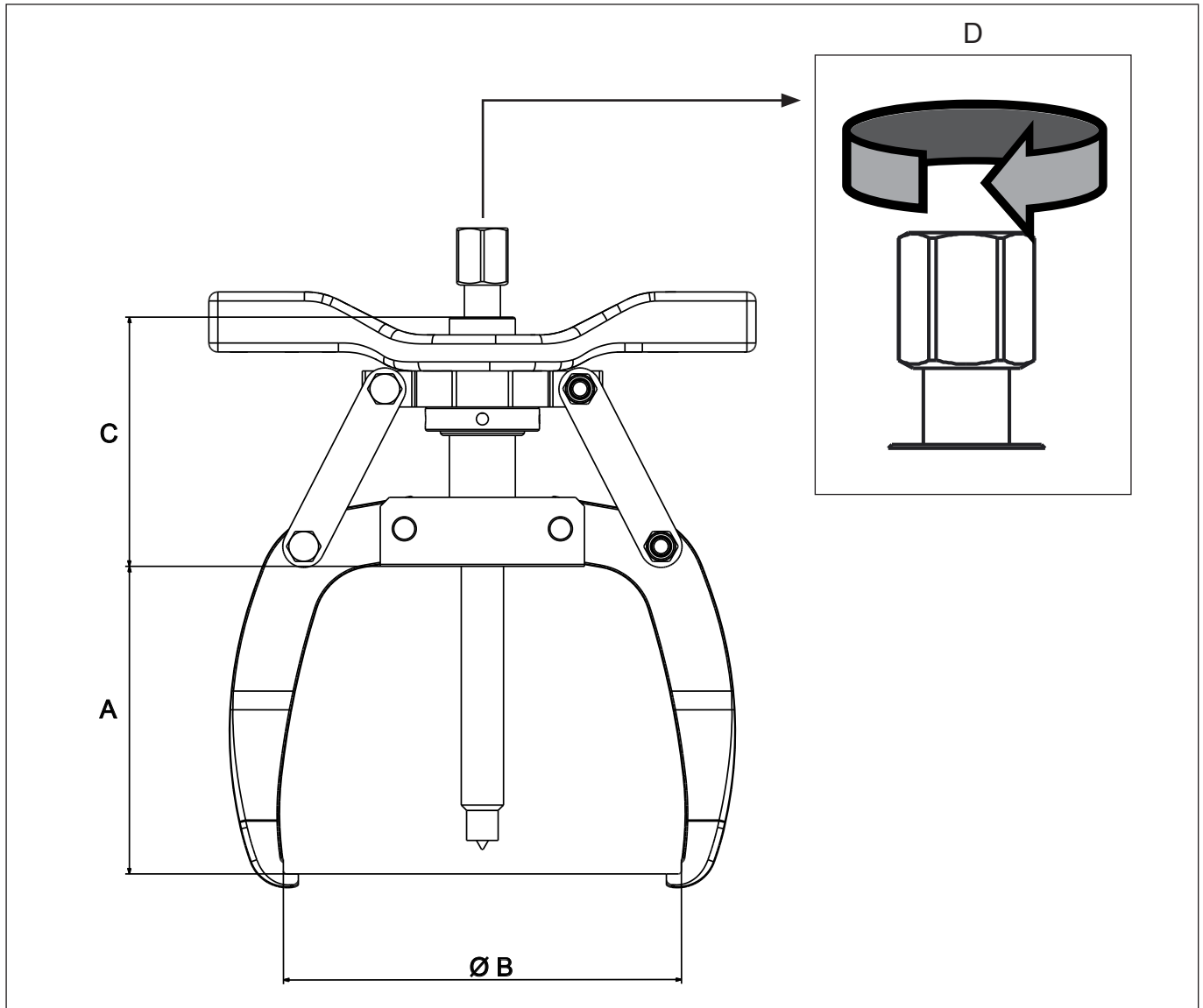

Puller Model Number	Capacity		A		ØB min.		ØB max.		C		D max.		Puller Weight	
	US Tons	kN	in	mm	in	mm	in	mm	in	mm	Nm	lb ft	lb	Kg
LGM203	3.0	26.7	4.02	102	1.10	28	5.20	132	2.36	60	90	66.38	3.74	1.7
LGM305	5.0	44.5	4.02	102	1.10	28	5.20	132	2.36	60	90	66.38	4.62	2.1
LGM204	4.0	35.6	5.59	142	1.18	30	7.32	186	3.54	90	180	132.76	5.50	2.5
LGM306	5.5	48.9	5.59	142	1.18	30	7.32	186	3.54	90	180	132.76	6.82	3.1
LGM207	7.0	62.3	6.97	177	1.38	35	10.24	260	5.28	134	355	261.83	10.78	4.9
LGM308	8.0	71.2	6.97	177	1.38	35	10.24	260	5.28	134	355	261.83	15.18	6.9
LGM211	11.0	97.9	8.46	215	3.31	84	11.81	300	4.96	126	469	345.92	14.74	6.7
LGM313	13.0	115.7	8.46	215	3.31	84	11.81	300	4.96	126	469	345.92	21.56	9.8

9.2 Specifications and Dimensions - Puller Spindle

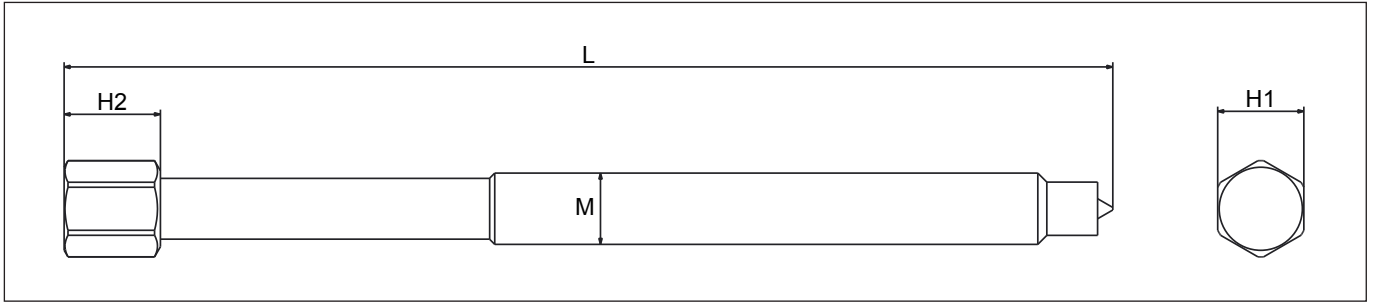

Puller Model Number	L		H1		H2		M
	in	mm	in	mm	in	mm	
LGM203	8.15	207	0.67	17	0.75	19	9/16" UNF
LGM305	8.15	207	0.67	17	0.75	19	9/16" UNF
LGM204	13.37	339.5	0.79	20	0.98	25	M18 X 1.5
LGM306	13.37	339.5	0.79	20	0.98	25	M18 X 1.5
LGM207	13.37	339.5	0.79	20	0.98	25	M18 X 1.5
LGM308	13.37	339.5	0.79	20	0.98	25	M18 X 1.5
LGM211	13.39	340	0.87	22	0.98	25	M20 X 1.5
LGM313	13.39	340	0.87	22	0.98	25	M20 X 1.5

9.3 Specifications and Dimensions - Puller Jaws

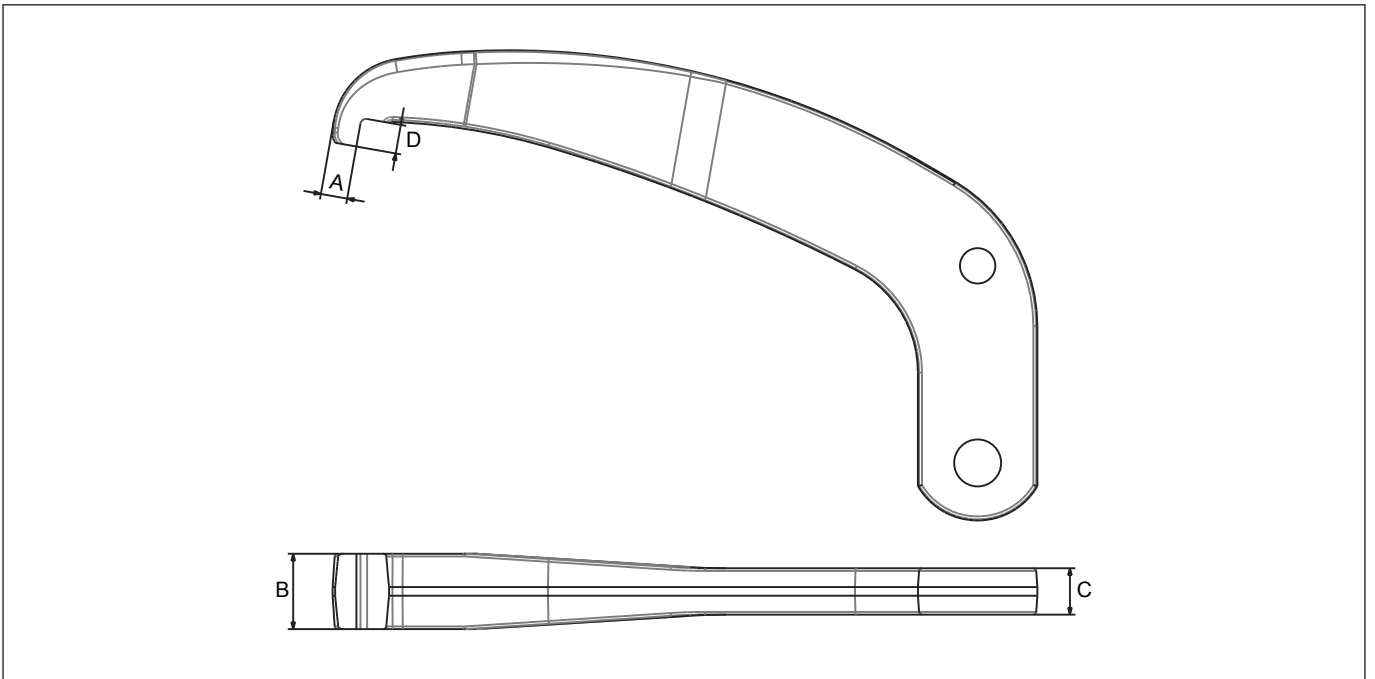

Puller Model Number.	A		B		C		D	
	in	mm	in	mm	in	mm	in	mm
LGM203 / LGM305	0.18	4.6	0.51	13	0.31	8	0.20	5.0
LGM204 / LGM306	0.26	6.7	0.63	16	0.31	8	0.31	7.8
LGM207 / LGM308	0.38	9.6	0.75	19	0.39	10	0.36	9.1
LGM211 / LGM313	0.47	11.9	0.94	24	0.47	12	0.47	12.0

ENERPAC 
POWERFUL SOLUTIONS. GLOBAL FORCE.