

Document Number	Document Revision	Document Revision Date	Product Date Code Beginning With
L4181	A	07/2017	A

NOTICE:

To ensure optimum performance of the repaired product, Enerpac recommends the installation of ALL parts included in a service assembly or repair kit.

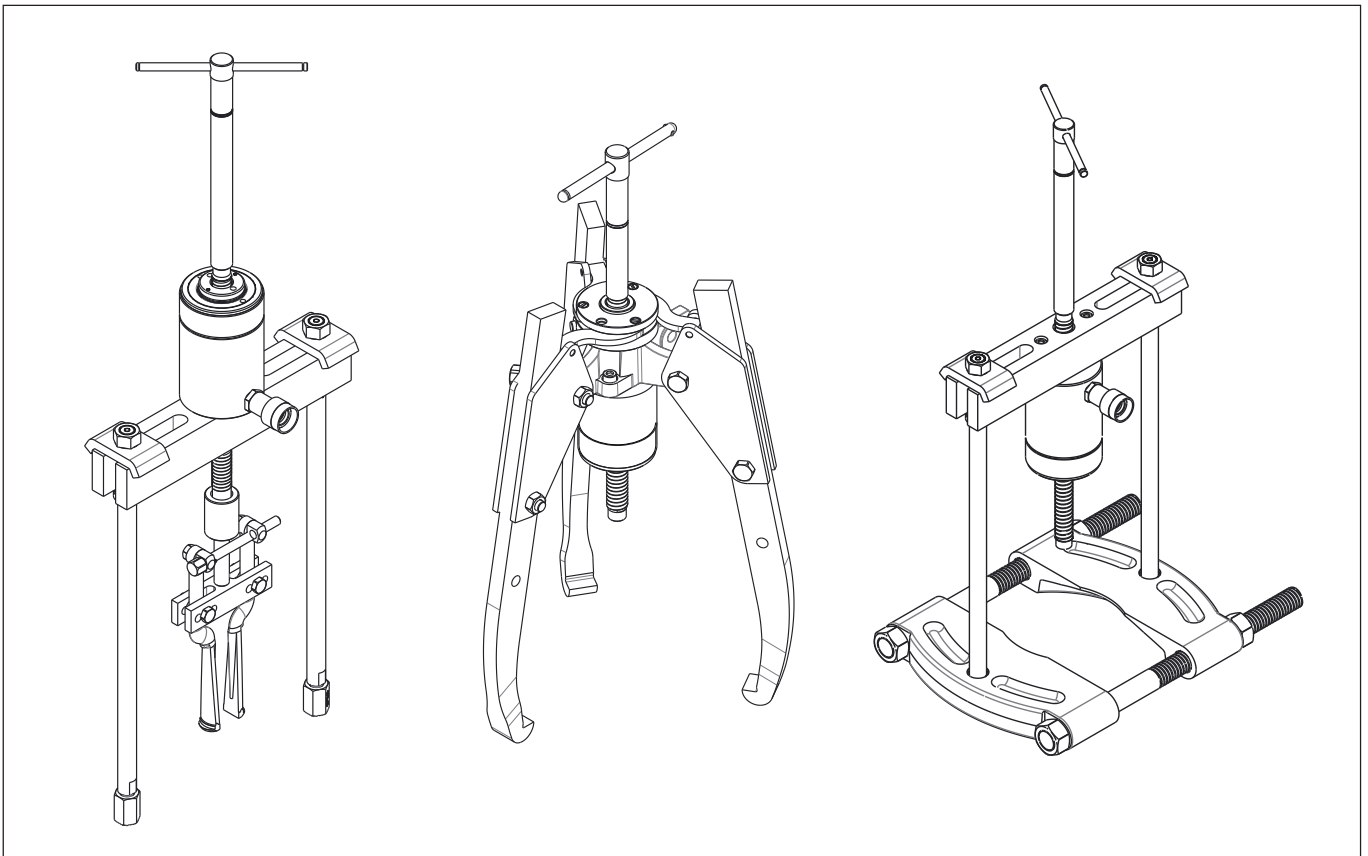

Table of Contents:

	Page
Figure 1 - Sync-Grip Puller - SGH14.	2
Figure 2 - Sync-Grip Puller - SGH24, SGH36 and SGH64.	2
Figure 3 - MPS Maintenance Set (Bearing Race Puller)	3
Figure 4 - MPS Maintenance Set (Cross Bearing Puller & Bearing Separator Attachment)	3
Figure 5 - Legs	4

⚠ WARNING Be certain that hydraulic pressure is completely relieved (0 psi/bar) and that load has been removed from tool before beginning any adjustment, maintenance or repair procedures. Appropriate shop safety procedures are to be followed during disassembly and reassembly to minimize any possibility of injury.

Figure 1 - Sync-Grip Puller SGH14

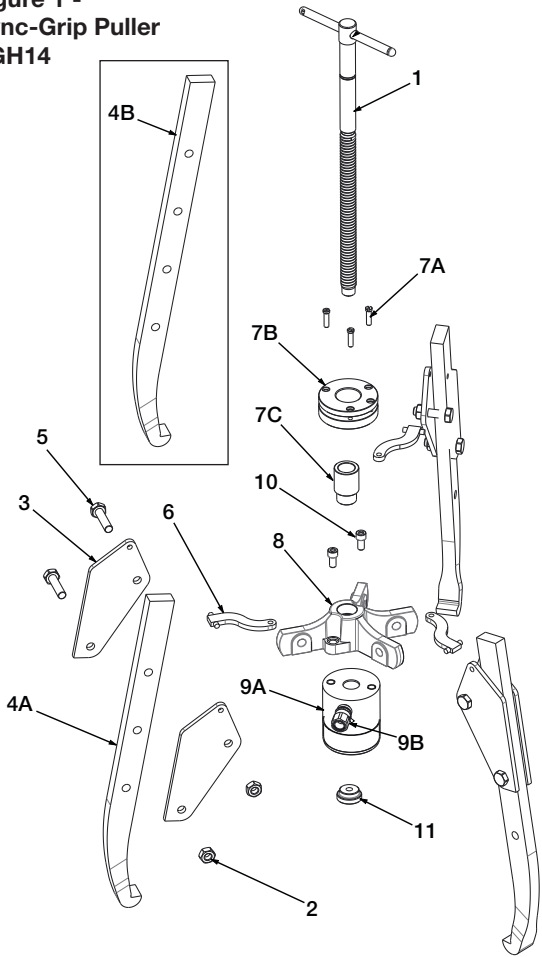
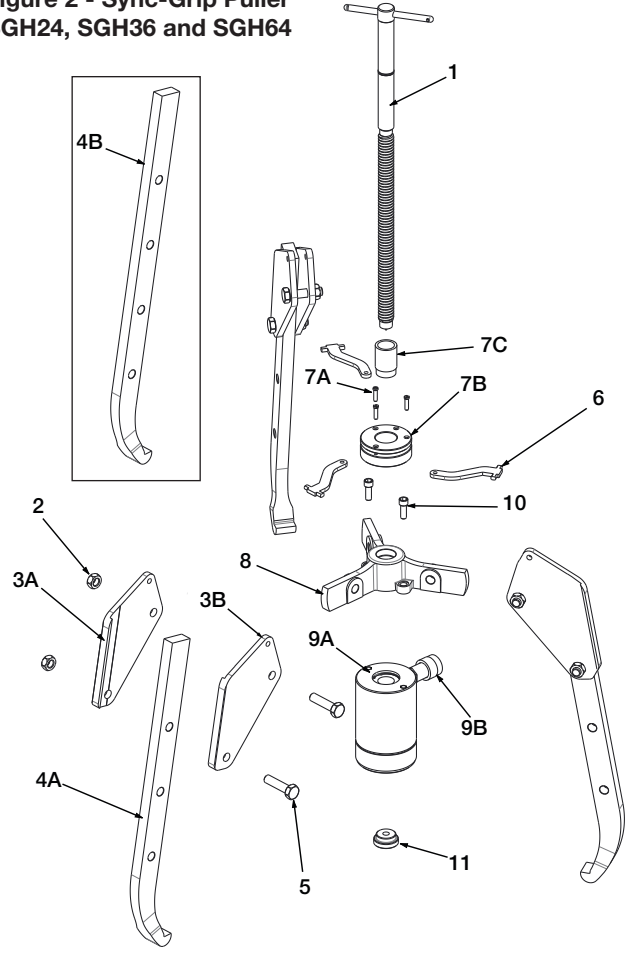

Figure 2 - Sync-Grip Puller SGH24, SGH36 and SGH64



Repair Parts List for Figures 1 and 2

Item	Puller Model/Part Number				Qty.	Description
	SGH14	SGH24	SGH36	SGH64		
1	SGH1001	SGH2001	SGH3001	SGH6001	1	Adjusting Rod (spindle)
2	★SGH1004	◆SGH2004	+SGH3004	*SGH6004	6	Nut
3	⊕	*	*	*	6	Plate (interchangeable left or right-hand)
3A	*	⊗	⊖	⊗	3	Plate (left-hand)
3B	*	⊗	⊖	⊗	3	Plate (right-hand)
4A	SG1008	SG2008	SG3008	SG6008	1	Jaw, Standard Length (1 jaw)
	SG1003K	SG2003K	SG3003K	SG6003K	3	Jaw, Standard Length (accessory kit - 3 jaws)
4B	SG1009	SG2009	SG3009	SG6009	1	Jaw, Extended Reach (1 jaw)
	SG1002K	SG2002K	SG3002K	SG6002K	3	Jaw, Extended Reach (accessory kit - 3 jaws)
5	★	◆	+	*	6	Capscrew
6	⊕	⊗	⊖	⊗	3	Strap
7A	★	◆	+	*	3	Screw, Self-Centering
7B	⊗	⊗	⊗	⊗	1	Assembly, Self-Centering Ring
7C	⊗	⊗	⊗	⊗	1	Bushing, Self-Centering
8	⊗	⊗	⊗	⊗	1	Body
9A	RWH121	RCH202	RCH302	RCH603	1	Hydraulic Cylinder
9B	▼AR630	⚡CR400	⚡CR400	⚡CR400	1	Hydraulic Coupler
10	HP1120	HP2113	HP2013	HP5013	2	Kit, Mounting Screw (short)
11	SGH1004	SGH2004	SGH3004	SGH6004	1	Point Protector

Notes:

- ★ Included in Hardware Kit SG1006K.
- ◆ Included in Hardware Kit SG2006K.
- + Included in Hardware Kit SG3006K.
- * Included in Hardware Kit SG6006K.
- ⊕ Included in Strap Kit SG1007K.
- ⊗ Included in Strap Kit SG2007K.
- ⊖ Included in Strap Kit SG3007K.
- ⊗ Included in Strap Kit SG6007K.
- ▼ Not Included with item 9A (order separately).
- ⚡ Included with item 9A.
- ⊗ Item not available as replacement part.
- * Item not used on this puller model.

**Figure 3 - MPS Maintenance Set
(Bearing Race Puller)**

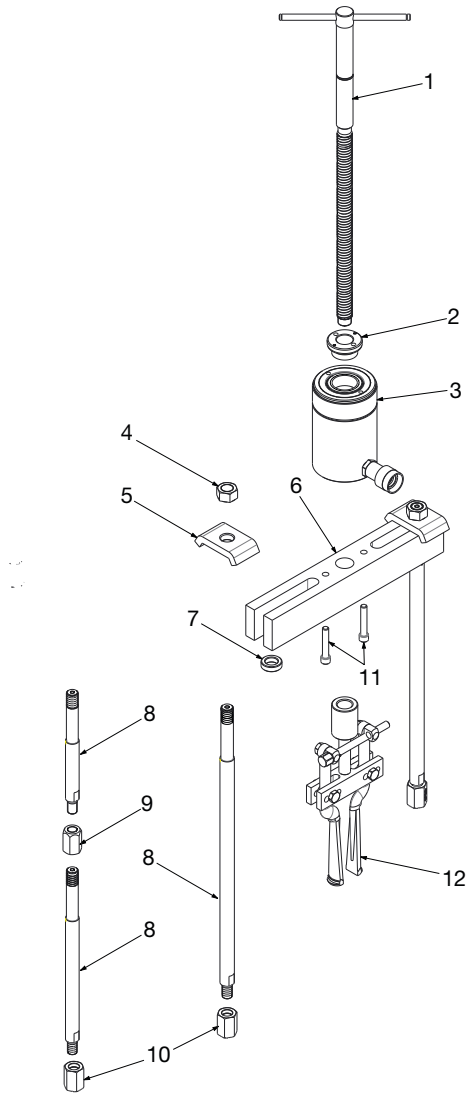

**Figure 4 - MPS Maintenance Set
(Cross Bearing Puller and Bearing
Separator Attachment)**

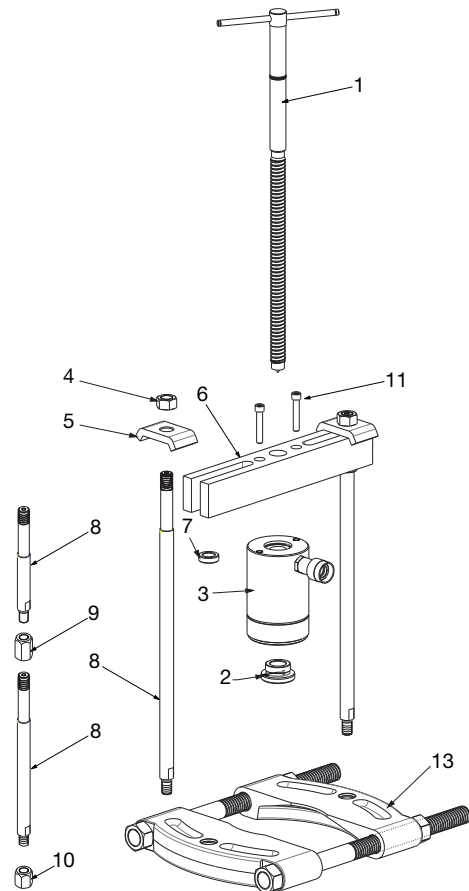

Repair Parts List for Figures 3 and 4

Item	Master Puller Set Model/Part Number				Qty.		Description
	MPS14	MPS24	MPS36	MPS64	Fig. 3	Fig. 4	
1	SGH1001	SGH2001	SGH3001	SGH6001	1	1	Adjusting Rod (spindle)
2	*	HP2015	HP3015	HP5016	1	1	Threaded Saddle
3	(See Fig. 1)	(See Fig. 2)	(See Fig. 2)	(See Fig. 2)	1	1	Hydraulic Cylinder
4	HP2001	HP2001	HP3031	HP5001	2	2	Kit, Leg Nut
5	HP1105	HP2105	HP3135	HP5102	2	2	Slide Plate
6	HP1103	HP2103	HP3104	HP5103	1	1	Slotted Crosshead
7	HP1102	HP2002	HP3032	*	2	2	Leg Washer
8	(See Fig. 5)	(See Fig. 5)	(See Fig. 5)	(See Fig. 5)	1	1	Leg
9	HP2031	HP2031	HP3041	*	4	4	Kit, Leg Reducer
10	HP2009	HP2009	HP3039	*	2	2	Kit, Leg End
11	HP1120	HP2113	HP2013	HP5013	2	2	Kit, Mounting Screw (short)
	HP1213	HP2213	HP3113	HP5113	2	2	Kit, Mounting Screw (long)
12	BHP180	BHP280	BHP380	BHP580	1	-	Internal Bearing Race Puller
13	BHP181	BHP282	BHP382	BHP582	-	1	Bearing Separator Attachment

Notes:

* Item not used on this master puller set model.

Figure 5 - Legs
(For use with components
shown in Fig. 3 and 4)

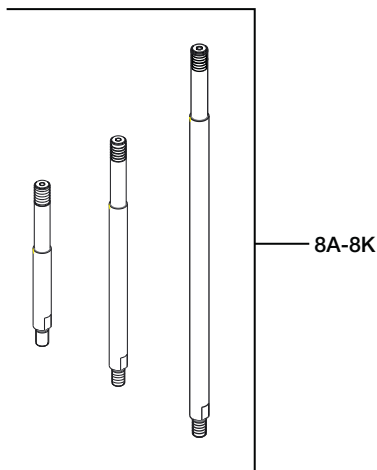

Repair Parts List for Figure 5				
Item	Leg Part Number	Leg Length		Used on Master Puller Set Models:
		inch	mm	
8A	HP1136	4.2	106	MPS14, BHP162, BHP1752, BHP1772
8B	HP1137	14.1	357	
8C	HP2006	9.4	240	MPS24, BHP261G, BHP2751G, BHP262
8D	HP2007	16.5	420	
8E	HP2008	22.4	570	
8F	HP2012	4.5	115	MPS36, BHP361G, BHP3751G, BHP362
8G	HP3036	8.0	204	
8H	HP3037	18.1	460	
8I	HP3038	28.0	710	MPS64, BHP561G, BHP5751G, BHP562
8J	HP5007	24.0	608.5	
8K	HP5008	34.0	863.5	

To Protect Your Warranty, Use Only ENERPAC Hydraulic Oil.

Enerpac recommends that all kit components be installed to insure optimum performance of the repaired product.



WARNING: STOP RINGS ON RWH CYLINDER MODELS ARE SPRING LOADED

IF NOT CONTAINED DURING DISASSEMBLY, SPRING AND STOP RING COULD CAUSE PERSONAL INJURY.

NOTE: Cylinder Base, item 1, is not available as a service item. Order complete cylinder.

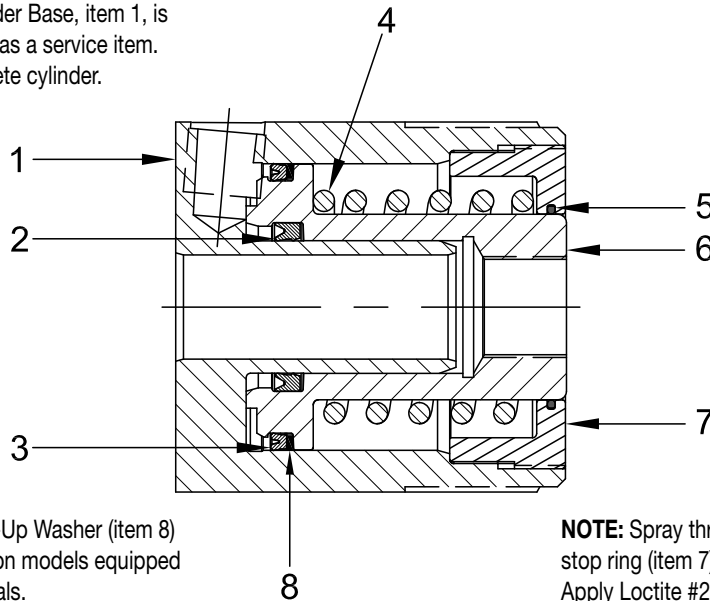

NOTE: Back-Up Washer (item 8) is only used on models equipped with Viton seals.

NOTE: Spray threads on base (item 1) and stop ring (item 7) with Loctite Activator #7471. Apply Loctite #222 to threads after Activator has dried. Assemble and torque stop ring (item 7) to 50-100 In-Lbs (5-11 Nm).

Parts List - Models RWH-121 and RWH-121V

Item	Model Number		Qty.	Description
	RWH-121	RWH-121V		
1	CH970030	CH970030	1	Base (not available as a service item)
2	DW1253041	(not used)	1	★ U-Cup, Standard
	(not used)	CF476041	1	❖ U-Cup, Viton
3	CJ422041	(not used)	1	★ U-Cup, Standard
	(not used)	CA520041	1	❖ U-Cup, Viton
4	Y397110	Y397110	1	Spring
5	B1028803	(not used)	1	★ O-Ring, Standard
	(not used)	B1028203	1	❖ O-Ring, Viton
6	CH971040	CH971040	1	Plunger
7	B47035	B47035	1	Stop Ring
8	(not used)	B1225564	1	❖ Back-Up Washer, Viton

★ Items included in and available only as part of Standard Repair Kit RWH121K1.

❖ Items included in and available only as part of Viton Repair Kit QMH120VK.

Enerpac Worldwide Locations

◆ e-mail: info@enerpac.com

◆ internet: www.enerpac.com

Africa

ENERPAC Middle East FZE
Office 423, JAFZA 15
P.O. Box 18004
Jebel Ali, Dubai
United Arab Emirates
Tel: +971 (0)4 8872686
Fax: +971 (0)4 8872687

Australia, New Zealand Actuant Australia Ltd.

Block V Unit 3
Regents Park Estate
391 Park Road
Regents Park NSW 2143
(P.O. Box 261) Australia
Tel: +61 297 438 988
Fax: +61 297 438 648

Brazil

Power Packer do Brasil Ltda.
Rua dos Inocentes, 587
04764-050 - Sao Paulo (SP)
Tel: +55 11 5687 2211
Fax: +55 11 5686 5583
Toll Free in Brazil:
Tel: 0800 891 5770
vendasbrasil@enerpac.com

Canada

Actuant Canada Corporation
6615 Ordan Drive, Unit 14-15
Mississauga, Ontario L5T 1X2
Tel: +1 905 564 5749
Fax: +1 905 564 0305
Toll Free:
Tel: +1 800 268 4987
Fax: +1 800 461 2456
Technical Inquiries:
techservices@enerpac.com

China

Actuant Industries Co. Ltd.
No. 6 Nanjing Road
Taicang Economic Dep Zone
Jiangsu, China
Tel: +86 0512 5328 7529
+86 0512 5328 7500 7529
Fax: +86 0512 5335 9690

Actuant China Ltd. (Peking)

709B Diyang Building
Xin No. 2
Dong San Huan North Rd.
Beijing City
100028 China
Tel: +86 10 845 36166
Fax: +86 10 845 36220

France, Switzerland francophone

ACTUANT - ENERPAC
France S.A., ZA de Courtaboeuf
32, avenue de la Baltique
91140 Villebon / Yvette
France
Tel: +33 1 60 13 68 68
Fax: +33 1 69 20 37 50

Germany, Austria, Switzerland, Greece, Baltic States, Central and Eastern Europe

ENERPAC GmbH
P.O. Box 300113
D-40401 Düsseldorf
Willstätterstrasse 13
D-40549 Düsseldorf
Germany
Tel: +49 211 471 490
Fax: +49 211 471 49 28

India

ENERPAC Hydraulics
(India) Pvt. Ltd.
No. 1A,
Peenya Industrial Area,
IInd Phase
Bangalore, 560 058 India
Tel: +91 80 40 792 777
Fax: +91 80 40 792 792

Italy

ENERPAC S.p.A.
Via Canova 4
20094 Corsico (Milano)
Tel: +39 02 4861 111
Fax: +39 02 4860 1288

Japan

Applied Power Japan LTD KK
Besshochou 85-7
Kita-ku,
Saitama-shi 331-0821
Japan
Tel: +81 48 662 4911
Fax: +81 48 662 4955

Middle East, Turkey and Caspian Sea

ENERPAC Middle East FZE
Office 423, JAFZA 15
P.O. Box 18004
Jebel Ali, Dubai
United Arab Emirates
Tel: +971 (0)4 8872686
Fax: +971 (0)4 8872687

Russia and CIS (excl. Caspian Sea Countries)

Actuant LLC
Admiral Makarov Street 8
125212 Moscow, Russia
Tel: +7-495-9809091
Fax: +7-495-9809092

Sweden, Denmark, Norway, Finland and Iceland

ENERPAC Scandinavia AB
Fabriksgatan 7
412 50 Gothenburg
Sweden
Tel: +46 31 7990281
Fax: +46 31 7990010
scandinavianinquiries@enerpac.com

Singapore

Actuant Asia Pte. Ltd.
37C, Benoi Road Pioneer Lot,
Singapore 627796
Tel: +65 68 63 0611
Fax: +65 64 84 5669
Toll Free: +1800 363 7722
Technical Inquiries:
tech.service-sg@enerpac.com

South Korea

Actuant Korea Ltd.
3Ba 717,
Shihwa Industrial Complex
Jungwang-Dong, Shihung-Shi,
Kyunggi-Do
Republic of Korea 429-450
Tel: +82 31 434 4506
Fax: +82 31 434 4507

Spain and Portugal

ENERPAC SPAIN, S.L.
Avda. Los Frailes, 40 - Nave C
& D
Pol. Ind. Los Frailes
28814 DAGANZO DE ARRIBA
(Madrid)
Spain
Tel: +34 91 884 86 06
Fax: +34 91 884 86 11

Sweden, Denmark, Norway, Finland and Iceland

Enerpac Scandinavia AB
Fabriksgatan 7
412 50 Gothenburg
Sweden
Tel: +46 (0) 31 7990281
Fax: +46 (0) 31 7990010
Inquiries:
Scandinavianinquiries@enerpac.com

The Netherlands, Belgium, Luxembourg

ENERPAC B.V.
Galvanistraat 115, 6716 AE Ede
P.O. Box 8097, 6710 AB Ede
The Netherlands
Tel: +31 318 535 800
Fax: +31 318 525 613
+31 318 535 848
beneluxinquiries@enerpac.com
Technical Inquiries Europe:
techsupport.europe@enerpac.com

United Kingdom, Ireland

Enerpac Ltd
Bentley Road South
Darlaston, West Midlands
WS10 8LQ, United Kingdom
Tel: +44 (0)121 50 50 787
Fax: +44 (0)121 50 50 799

USA, Latin America and Caribbean

ENERPAC
P.O. Box 3241
6100 N. Baker Road
Milwaukee, WI 53209 USA
Tel: +1 262 781 6600
Fax: +1 262 783 9562

User inquiries:

+1 800 433 2766

Inquiries/orders:

+1 800 558 0530

Technical Inquiries:

techservices@enerpac.com

ENERPAC

704 W. Simonds
Dallas, TX 75159 USA
Tel: +1 972 287 2390
Fax: +1 972 287 4469

09/30/09

All Enerpac products are guaranteed against defects in workmanship and materials for as long as you own them. For your nearest authorized Enerpac Service Center, visit us at www.enerpac.com

⚠ WARNING
Stop rings on RCH and RWH models are spring loaded!
If not contained during disassembly, spring and stop ring could cause personal injury.

(S) Stop ring threads are staked. Stake mark must be removed prior to attempting to remove stop ring. Restake after testing repaired cylinder.

Use Loctite 545
or teflon tape.

Torque to 50-60 ft-lb.
[67,6-81,1 Nm]

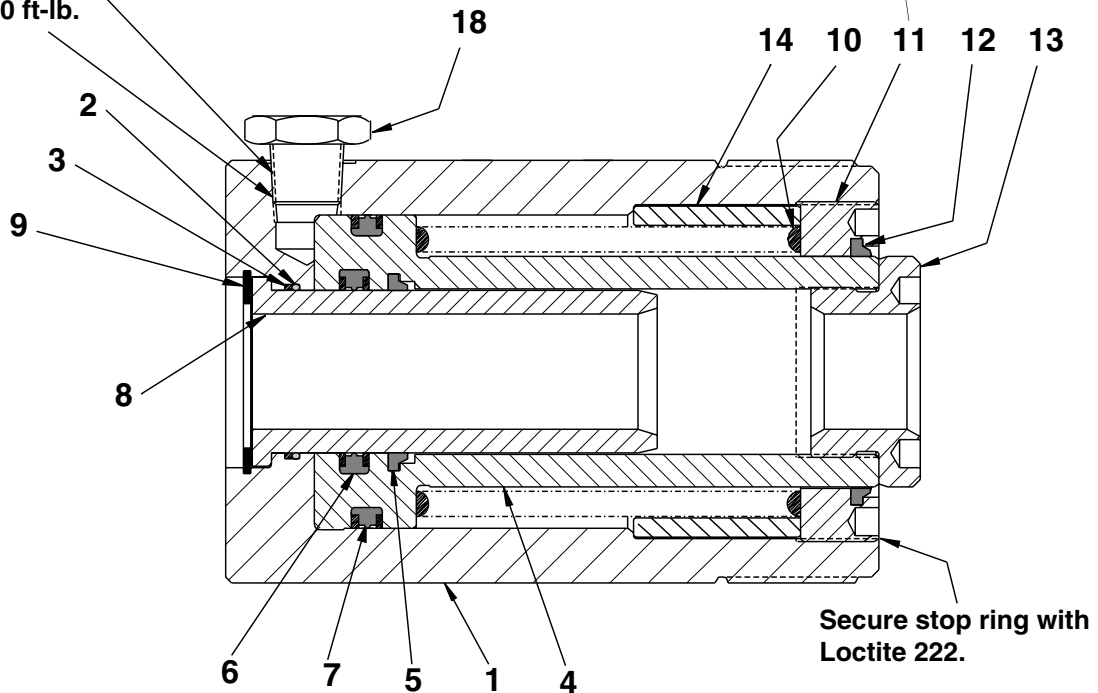

Secure stop ring with
Loctite 222.

NOTE: Cylinder Base, Item #1 is
not available as a service item.
Order Complete Cylinder.

INSTALL ALL KIT COMPONENTS TO INSURE OPTIMUM PERFORMANCE OF THE REPAIRED CYLINDER.

REPAIR PARTS LIST

Item No.	RCH-202	RWH-200 RWH-200V	RWH-202 RWH-202V	Quantity	Description
1				1	Cylinder Assembly
2	★	★	★	1	O-Ring
3	★	★	★	1	Back-up Ring
4	DA5164040	DA5163040	DA5164040	1	Plunger
5	★	★	★	1	Wiper Ring
6	★	★	★	1	G-T Ring
7	★	★	★	1	G-T Ring Viton
8	DA5160268	DA5159268	DA5160268	1	Center Tube
9	★	★	★	1	Retaining Ring
10	CF707110	CF707110	CF707110	1	Spring
11	CJ671044	CJ671044	CJ671044	1	Stop Ring
12	★	★	★	1	Wiper Ring Viton
13	CB894045	CB894045	CB894045	1	Saddle
14	CJ672044	CJ672044	CJ672044	1	Stop Ring
15	CR-400	—	—	1	Half Coupler (not shown)
18	—	FZ1630	FZ1630	1	Reducer Bushing

★ Indicates item included in and available only as part of Repair Kit RCH-202K.
For viton cylinders, order Repair Kit RCH-202KV1.

Australia
ENERPAC, Applied Power Australia Ltd.
Block V Unit 3,
Regents Park Estate,
391 Park Road
Regents Park NSW 2143
(P.O. Box 261) Australia
Tel: +61 297 438 988
Fax: +61 297 438 648

Brazil
Power Packer do
Brasil LTDA
Avenida Ferraz
Alvim nº 1012
(09961-550) - Diadema
São Paulo, Brazil
Tel: +55 11 4051 1188
Fax: +55 11 4051 3699

China
Shanghai Blackhawk
Machinery Co Ltd
15H Jinxuan Building
238 Nandan Road (E)
Shanghai, 200030, China
Tel: +86 21 6469 8732
Fax: +86 21 6469 8721

France, Greece, Turkey, Middle East,
Africa
ENERPAC S.A.
B.P. 200, Parc d'Activités
du Moulin de Massy
F-91882 Massy CEDEX (Paris) France
Tel: +33 01 601 368 68
Fax: +33 01 692 037 50

Germany, Denmark, Scandinavia,
Austria, Switzerland, Eastern
Europe, CIS
ENERPAC
Applied Power GmbH
P.O. Box 300113
D-40401 Düsseldorf, Germany
Tel: +49 211 471 490
Fax: +49 211 471 49 28/40

Holland, Belgium, Luxembourg,
ENERPAC B.V.
Storkstraat 25
P.O. Box 269
3900 AG Veenendaal, Holland
Tel: +31 318 535 911
Fax: +31 318 535 848
+31 318 526 645

Hong Kong
ENERPAC
Room 907 Workingberg
Commercial Building
41-47 Marble Road,
North Point
Tel: +852-2561 6295
Fax: +852-2561 6772

India
ENERPAC
Hydraulic (India) Pvt Ltd
Plot No. A-571
MIDC, TTC Industrial Area
Mahape-400 701,
Navi Mumbai, India
Tel: +91 22 769 47 78
Fax: +91 22 769 84 73

Italy
ENERPAC Applied Power Italiana S.p.A.
Via Canova 4,
20094 Corsico (Milano)
Tel: +39 2 486 111 00
Fax: +39 2 486 012 88

Japan
Applied Power Japan Ltd.
10-17 Sasame Kita-Machi
Toda-Shi, Saitama #335, Japan
Tel: +81 048 421 2311
Fax: +81 048 421 8949

Malaysia
Applied Power Hytec (M) Sdn Bhd 22-1,
Jalan SS 15/8B
Subang Jaya, 47500
P.J. Selangor
West Malaysia
Tel: (0203) 73729 23/39/19
Fax: (0203) 737 29 18

Mexico
ENERPAC Applied Power Mexico S.A. de
C.V.
Avenida Principal,
La Paz #100
Fracc. Industrial La Paz
42084 Pachuca, Hidalgo
Tel: +52 771 337 00
Fax: +52 771 838 00

Singapore
Applied Power Asia Pte Ltd
47 Jalan Pemimpin,
#01-02 & 01-03
Sin Cheong Bldg
Singapore 577200
Thomson Road,
P.O. Box 114
Singapore 915704
Tel: +65 258 16 77
Fax: +65 258 28 47

South Korea
ENERPAC
Applied Power Korea Ltd.
163-12 Dodang-Dong, Choong-Ku,
Buchun-shi, Kyunggi-Do
Republic of Korea
Tel: +82 32 675 08 36
Fax: +82 32 675 30 02

Spain, Portugal
ENERPAC Applied Power International S.A.
A. Valgrande 14
Nave 12
28108 Alcobendas (Madrid), Spain
Tel: +34 91 661 11 25
Fax: +34 91 661 47 89

United Kingdom, Ireland
ENERPAC Limited
Unit 3 Colemeadow Road
North Moons Moat, Redditch
Worcester B98 9PB
United Kingdom
Tel: +44 01527 598 900
Fax: +44 01527 585 500

USA, Canada, Latin America and
Caribbean
ENERPAC
6101 N. Baker Road
Milwaukee, WI 53209 USA
Tel: +1 414 781 66 00
Fax: +1 414 781 10 49

USA
User inquiries:
+1 800 433 2766
Distributor inquiries/orders:
+1 800 558 0530

Canada
User inquiries:
+1 800 426 4129
Distributor inquiries/orders:
+1 800 426 2284

Internet
www.enerpac.com

e-mail
info@enerpac.com

All Enerpac products are guaranteed against defects in workmanship and materials for as long as you own them.
Under this guarantee, free repair or replacement will be made to your satisfaction.

For your nearest authorized Enerpac Service Center, visit us at www.enerpac.com

Repair Parts Sheet	Revision	Revision Date	Product Code Beginning
L1627	Rev. J	11/2017	C



WARNING: STOP RINGS ON RCH MODELS ARE SPRING LOADED! IF NOT CONTAINED DURING DISASSEMBLY, SPRING AND STOP RING COULD CAUSE PERSONAL INJURY.

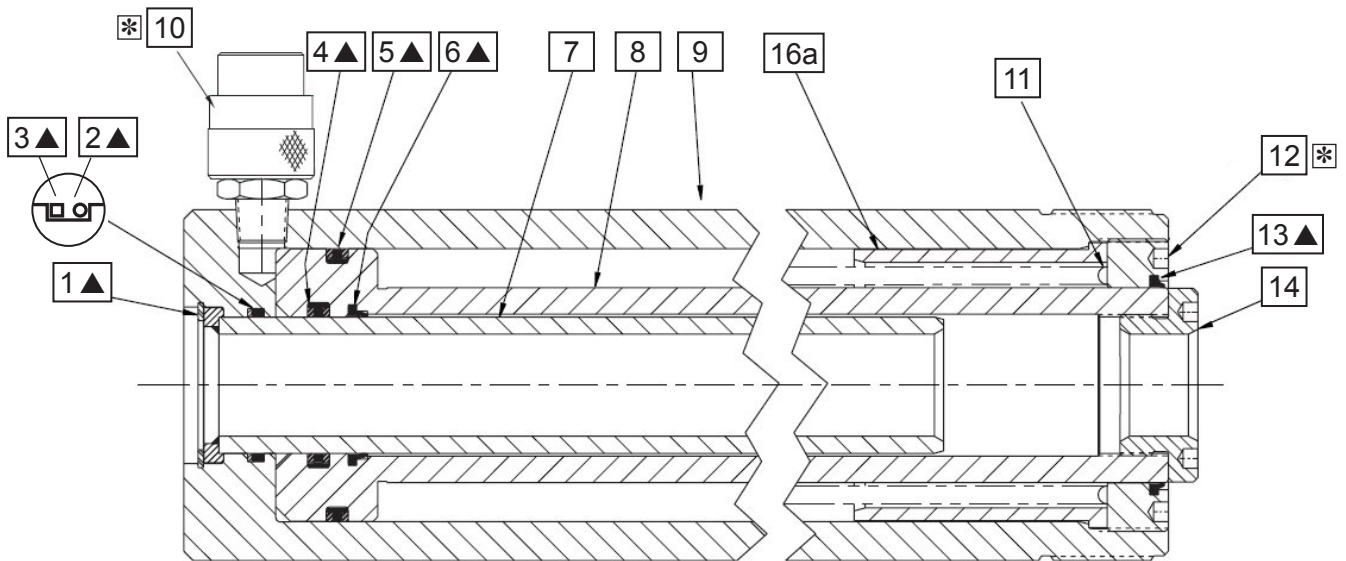

Models RCH302 and RCH306

▲ = Parts available in kits (see page 2).

* See  on page 2.

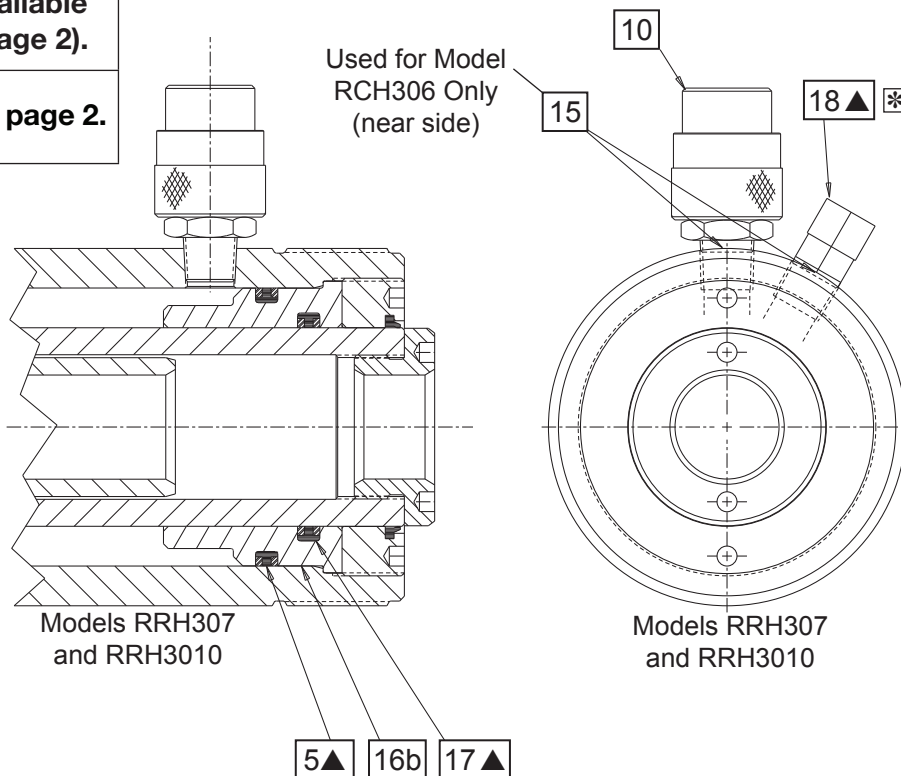

Models RRH307 and RRH3010

Models RRH307 and RRH3010

Repair Parts List						L1627
Item	Description	Qty.	RCH302	RCH306	RRH307	RRH3010
1	Retaining Ring ▲	1	A1006049	A1006049	A1006049	A1006049
2	O Ring ▲	1	B1090503	B1090503	B1090503	B1090503
3	Back Up Ring ▲	1	DA4984566	DA4984566	DA4984566	DA4984566
4	G T Ring ▲	1	B13271514	B13271514	B13271514	B13271514
	G T Ring ■	1	B13271516	B13271516	B13271516	B13271516
5	G T Ring ▲	1	B1338513	B1338513	B1338513 (Qty 2)	B1338513 (Qty 2)
	G T Ring ■	1	B1338515	B1338515	B1338515 (Qty 2)	B1338515 (Qty 2)
6	Wiper ▲	1	CJ142044	CJ142044	CJ142044	CJ142044
7	Center Tube	1	B1338515	B1338515	DA3468900	DA4101900
8	Plunger	1	DA4066040	DA3472040	DA3472040	DA4100040
9	Cylinder	1	Not available as service part. Order new cylinder.			
10	Coupler	1	CR400	CR400	---	---
	Coupler	2	---	---	CR400	CR400
11	Spring	1	CH259110	CR514110	---	---
12	Stopring	1	DA3464044	DA3464044	DA3464044	DA3464044
13	Wiper ▲	1	CJ50044	CJ50044	CJ50044	CJ50044
14	Saddle	1	CF698045	CF698045	CF698045	CF698045
15	Plug	1	---	A1009245	---	---
16a	Stop Tube	1	DA4069268	DA3466268	---	---
16b	Int. Stop Ring	1	---	---	DA3463044	DA3463044
17	G T Ring ▲	1	---	---	B1333514	B1333514
	G T Ring ■	1	---	---	B1333516	B1333516
18	Relief Valve ▲	1	---	---	CJ160900W	CJ160900W
19	Dust Cap (not shown) ▲	1	DD1782020	DD1782020	---	---
	Dust Cap (not shown) ▲	2	---	---	DD1782020	DD1782020
20	Thread Protector (not shown) ▲	1	CL402271	CL402271	CL402271	CL402271
21	Decal Warning (not shown) ▲	1	DA5625026	DA5625026	DA5625026	DA5625026
22	Decal Hollow (not shown) ▲	1	G668026	G668026	G668026	G668026
23	Decal, Warning (not shown) ▲	1	DA6027026	DA6027026	DC6154026	DC6154026
24	Coupler, O-Ring (not shown)	1	B1116803	B1116803	---	---
	Coupler, O-Ring (not shown)	2	---	---	B1116803	B1116803
	Repair Kit (standard seals)		RCH302K2	RCH302K2	RRH3010K2	RRH3010K2
	Repair Kit (Viton seals)		RWH302KV	RWH302KV	RWH302KV	RWH302KV

▲ = Indicates Items Included in Repair Kits RCH302K2 and RRH3010K2.

■ = Indicates Items Included in Repair Kits RWH302KV. Parts included in kits will vary, depending on kit ordered.

IMPORTANT: Shaded items are available only in kits (not sold separately).



Service Notes			L1627
Item	Model	Torque / Remark	
10	RCH / RRH	40 - 60 ft-lbs [54 - 81 Nm]	
10	RCH / RRH	Use Loctite 545 or Teflon tape	
12	RCH / RRH	Use Loctite 222	
18	RRH	40 - 60 ft-lbs [54 - 81 Nm]	
18	RRH	Set safety valve to 11,000 - 11,500 psi [760 - 795 bar]	
18	RRH	Use Loctite 545 or Teflon tape	



To maintain your warranty:

- Use only Enerpac Oil
- Have your products inspected and repaired by an Enerpac Authorized Service Center

ENERPAC

Visit www.enerpac.com for the location of the Enerpac Authorized Service Center nearest you.

To Protect Your Warranty, Use Only ENERPAC Hydraulic Oil.

Enerpac recommends that all kit components be installed to insure optimum performance of the repaired product.

WARNING! Stop rings on RCH models are spring loaded! If not contained during disassembly, spring and stop ring could cause personal injury.

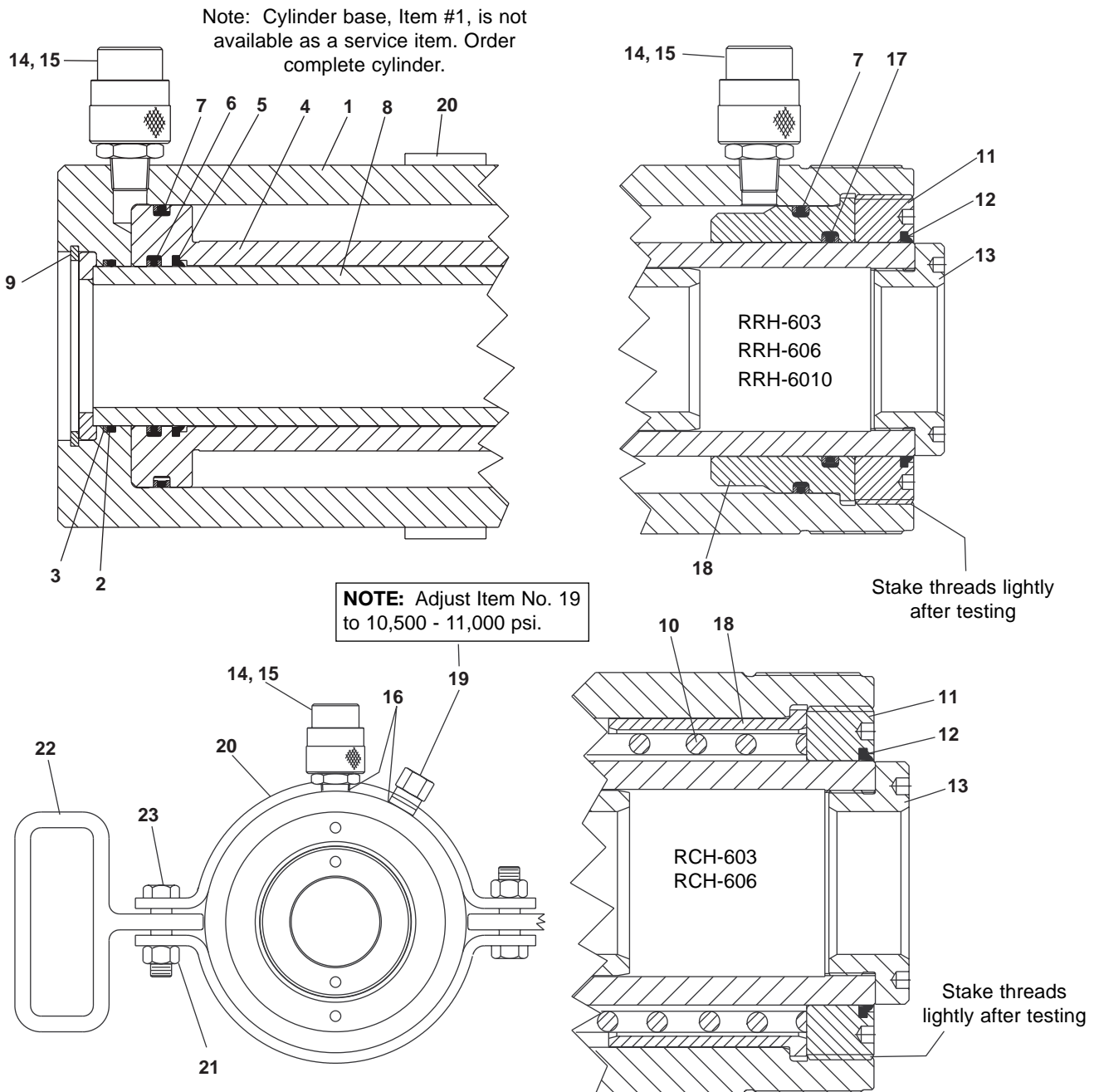

Figure 1

Item	RCH-603	RCH-606	RRH-603	RRH-606	RRH-6010	Qty.	Description
1		Order Complete	Cylinder			1	Cylinder
2	★	★	★	★	★	1	O-Ring
3	★	★	★	★	★	1	Back-Up Ring
4	DA4806040	DA4807040	DA4806040	DA4807040	DA4808040	1	Plunger
5	★	★	★	★	★	1	Wiper Ring
6	★	★	★	★	★	1	G-T Ring Assembly
7	★	★	★	★	★	2	G-T Ring Assembly (RCH Models use 1)
8	DA4809900	DA4810900	DA4809900	DA4810900	DA4811900	1	Center Tube
9	★	★	★	★	★	1	Retaining Ring
10	DA4816110	DA4816110	-----	-----	-----	1	Spring
11	CR106044	CR106044	CR106044	CR106044	CR106044	1	Stop Ring
12	★	★	★	★	★	1	Wiper Ring
13	CB891045	CB891045	CB891045	CB891045	CB891045	1	Saddle
14	CR400	CR400	CR400	CR400	CR400	2	Coupler (RCH Models use 1)
15	CD411	CD411	CD411	CD411	CD411	2	Dust Cap (Not Shown) (RCH Models use 1)
16	A1009245	A1009245	-----	-----	-----	2	Flush Plug (RCH Models Only)
17	-----	-----	★	★	★	1	G-T Ring Assembly
18	DA4814268	DA4814268	DA4813044	DA4813044	DA4813044	1	Inner Stop Ring
19	-----	-----	CJ160900W	CJ160900W	CJ160900W	1	Relief Valve Assembly
20	DA5238900SR	DA5238900SR	DA5238900SR	DA5238900SR	DA5238900SR	2	Collar (Incl.It.#21,22,23)
21	-----	-----	-----	-----	-----	2	Nut
22	-----	-----	-----	-----	-----	2	Handle
23	-----	-----	-----	-----	-----	2	Bolt
	RRH603K4	RRH603K4	RRH603K4	RRH603K4	RRH603K4	1	Repair Kit

★ Indicates Items Included in and Available Only in Repair Kits.

Enerpac Worldwide Locations

Africa

ENERPAC Middle East FZE
P.O. Box 18004
Jebel Ali, Dubai
United Arab Emirates
Tel: +971 (0)4 8872686
Fax: +971 (0)4 8872687

Australia

Actuant Australia Ltd.
Block V Unit 3
Regents Park Estate
391 Park Road
Regents Park NSW 2143
(P.O. Box 261) Australia
Tel: +61 297 438 988
Fax: +61 297 438 648

Brazil

Power Packer do Brasil Ltda.
Rua dos Inocentes, 587
04764-050 - Sao Paulo (SP)
Tel: +55 11 5687 2211
Fax: +55 11 5686 5583
Toll Free in Brazil:
Tel: 0800 891 5770
vendasbrasil@enerpac.com

Canada

Actuant Canada Corporation
6615 Ordan Drive, Unit 14-15
Mississauga, Ontario L5T 1X2
Tel: +1 905 564 5749
Fax: +1 905 564 0305
Toll Free:
Tel: +1 800 268 4987
Fax: +1 800 461 2456
Technical Inquiries:
techservices@enerpac.com

China

Actuant China Ltd.
1F, 269 Fute N. Road
Waigaoqiao Free Trade Zone
Pudong New District
Shanghai, 200 131 China
Tel: +86 21 5866 9099
Fax: +86 21 5866 7156

Actuant China Ltd. (Beijing)

709B Diyang Building
Xin No. 2
Dong San Huan North Rd.
Beijing City
100028 China
Tel: +86 10 845 36166
Fax: +86 10 845 36220

Central and Eastern Europe, Greece

ENERPAC B.V.
Galvanistraat 115
P.O. Box 8097
6710 AB Ede
The Netherlands
Tel: +31 318 535 936
Fax: +31 318 535 951

France, Switzerland francophone

ENERPAC
Une division de ACTUANT
France S.A.
B.P. 200, Parc d'Activités
du Moulin de Massy
F-91882 Massy CEDEX France
Tel: +33 1 60 13 68 68
Fax: +33 1 69 20 37 50

◆ e-mail: info@enerpac.com

Germany, Austria, Greece and Switzerland

ENERPAC GmbH
P.O. Box 300113
D-40401 Düsseldorf
Germany
Tel: +49 211 471 490
Fax: +49 211 471 49 28

India

ENERPAC Hydraulics
(India) Pvt. Ltd.
Office No. 9, 10 & 11,
Plot No. 56, Monarch Plaza,
Sector 11, C.B.D. Belapur
Navi Mumbai 400614, India
Tel: +91 22 2756 6090
Tel: +91 22 2756 6091
Fax: +91 22 2756 6095

Italy

ENERPAC S.p.A.
Via Canova 4
20094 Corsico (Milano)
Tel: +39 02 4861 111
Fax: +39 02 4860 1288

Japan

Applied Power Japan Ltd.
Besshochou 85-7
Saitama-shi, Kita-ku,
Saitama 331-0821
Japan
Tel: +81 48 662 4911
Fax: +81 48 662 4955

Middle East, Turkey and Caspian Sea

ENERPAC Middle East FZE
P.O. Box 18004
Jebel Ali, Dubai
United Arab Emirates
Tel: +971 (0)4 8872686
Fax: +971 (0)4 8872687

Russia and CIS

(excl. Caspian Sea Countries)

Actuant LLC
Admiral Makarov Street 8
125212 Moscow, Russia
Sector 11, C.B.D. Belapur
Navi Mumbai 400614, India
Tel: +7-495-9809091
Fax: +7-495-9809092

Singapore

Actuant Asia Pte. Ltd.
25 Serangoon North Ave. 5
#03-01 Keppel Digihub
Singapore 554914
Thomson Road
P.O. Box 114
Singapore 915704
Tel: +65 64 84 5108
+65 64 84 3737
Fax: +65 64 84 5669

Toll Free: +1800 363 7722

Technical Inquiries:
techsupport@enerpac.com.sg

South Korea

Actuant Korea Ltd.
3Ba 717,
Shihwa Industrial Complex
Jungwang-Dong, Shihung-Shi,
Kyunggi-Do
Republic of Korea 429-450
Tel: +82 31 434 4506
Fax: +82 31 434 4507

◆ internet: www.enerpac.com

Spain and Portugal

ENERPAC
C/San José Artesano 8
Pol. Ind.
28108 Alcobendas
(Madrid) Spain
Tel: +34 91 661 11 25
Fax: +34 91 661 47 89

The Netherlands, Belgium, Luxembourg, Sweden, Denmark, Norway, Finland and Baltic States

ENERPAC B.V.
Galvanistraat 115
P.O. Box 8097, 6710 AB Ede
The Netherlands
Tel: +31 318 535 911
+31 318 525 613
Fax: +31 318 535 848

Technical Inquiries Europe:
techsupport.europe@enerpac.com

United Kingdom, Ireland

Enerpac Ltd
Bentley Road South
Darlaston, West Midlands
WS10 8LQ, United Kingdom
Tel: +44 (0)121 50 50 787
Fax: +44 (0)121 50 50 799

USA, Latin America and Caribbean

ENERPAC
P.O. Box 3241
6100 N. Baker Road
Milwaukee, WI 53209 USA
Tel: +1 262 781 6600
Fax: +1 262 783 9562

Inquiries/orders:
+1 800 558 0530

Technical Inquiries:
techservices@enerpac.com

All Enerpac products are guaranteed against defects in workmanship and materials for as long as you own them. For your nearest authorized Enerpac Service Center, visit us at www.enerpac.com

Document Number	Document Revision	Document Revision Date	Product Date Code Beginning With
L4006	C	05/2017	A, B or C

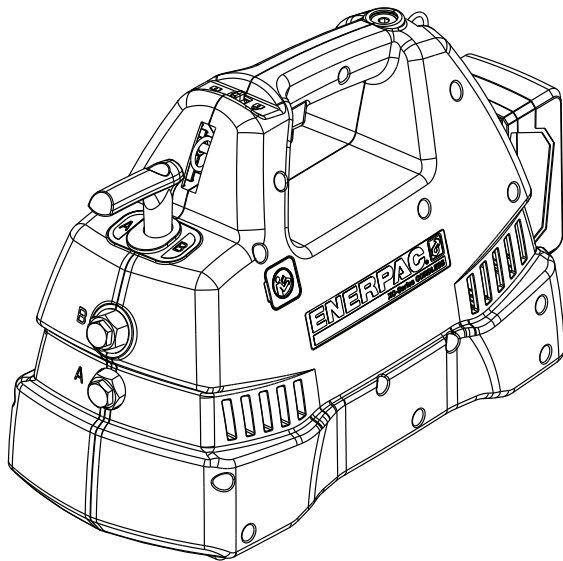

Product Information: Model Number, Serial Number, Maximum Pressure and Date Code.

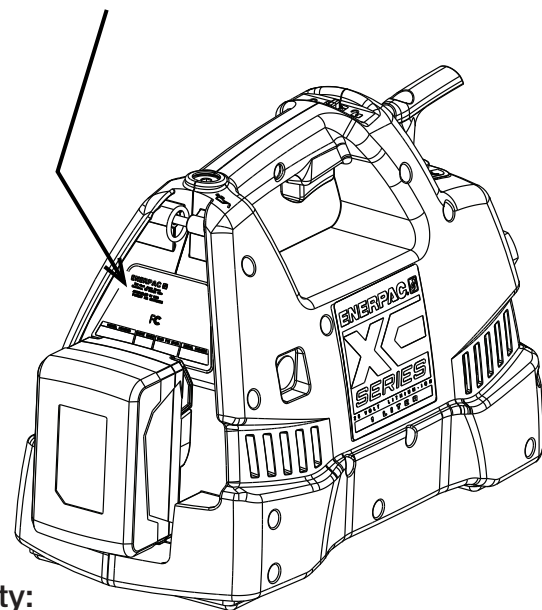

IMPORTANT: To maintain your warranty:

- Use only Enerpac Oil.
- Have your products inspected and repaired by an Enerpac Authorized Service Center.

Table of Contents:

	Page		Page
Fig. 1, Decals, Plugs, Caps & Shoulder Strap	2	Fig. 9, Control Valve, 4-Way, 3-Position (XC-1400 Models Only)	11
Fig. 2, Pump LH Shroud & Hardware	3	Fig. 10, Valve Cover Assembly, 4-Way, 3-Position Control Valve (XC-1400 Models Only)	12
Fig. 3A, Pump RH Shroud & Electrical Components .4		Fig. 11, Eccentric Shaft & Housing Subassembly	13
Fig. 3B, Electrical Components, Old Style	5	Fig. 12, Eccentric Shaft Subassembly	14
Fig. 4, Oil Fill & Vent Lines	6	Fig. 13, Pump Assembly	14
Fig. 5, Power Unit Assembly	7	Fig. 14, Pump Element	15
Fig. 6, Release Valve & Eccentric Assembly (XC-1200 Models Only)	8	Fig. 15, Battery & Charger	16
Fig. 7, Release Valve Subassembly (XC-1200 Models Only)	9	Fig. 16A, Electrical Schematic, Date Code A & B	17
Fig. 8, Control Valve, 4-Way, 3-Position (XC-1400 Models Only)	10	Fig. 16B, Electrical Schematic, Date Code C	18
		Service Information	19

⚠ WARNING Fully relieve hydraulic pressure, remove battery, and disconnect hydraulic hoses before beginning any maintenance, repair or inspection procedures. Failure to observe these precautions could result in death or serious personal injury.

Fig. 1, Decals, Plugs, Caps & Shoulder Strap

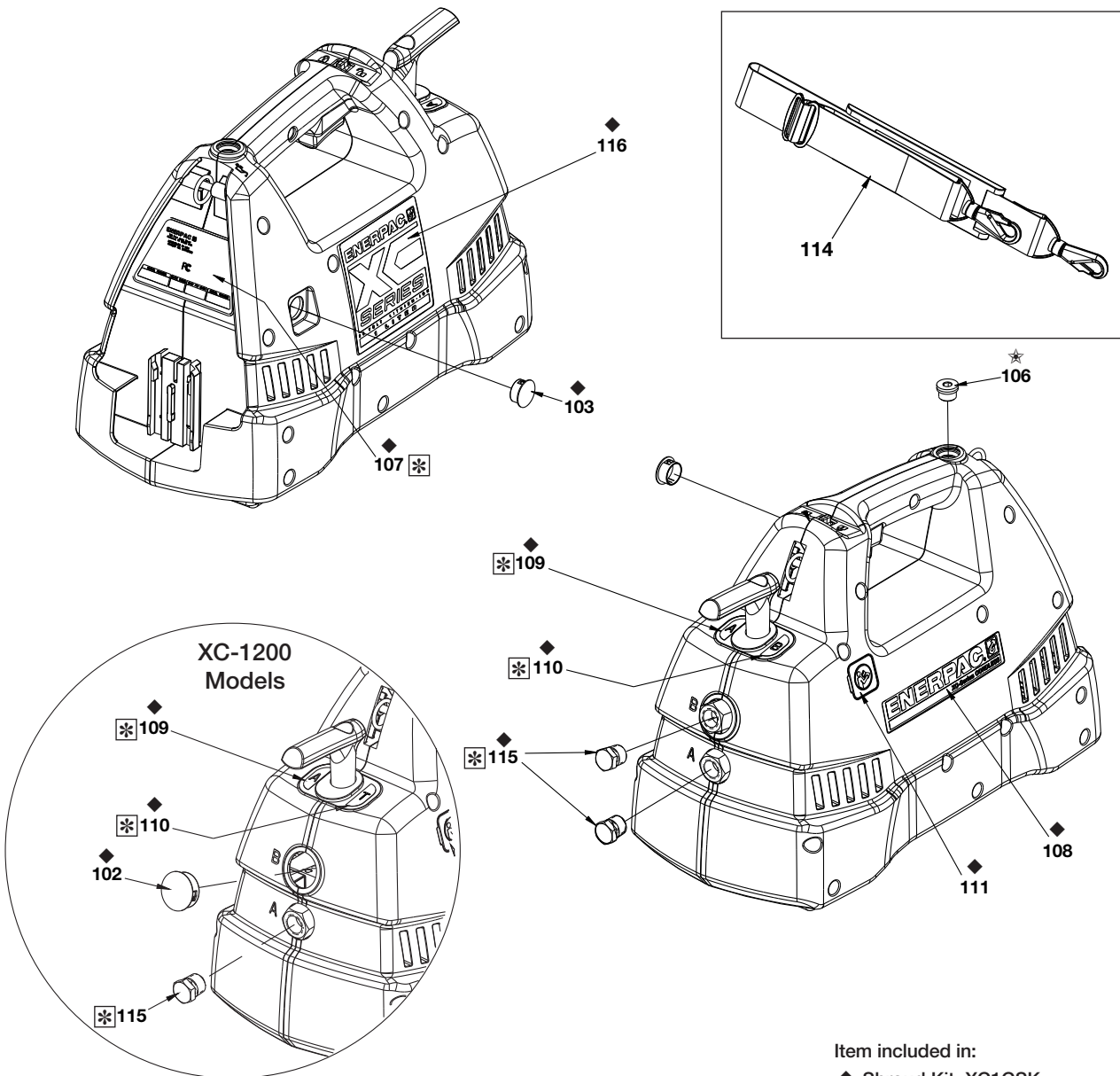

Item included in:
 ◆ Shroud Kit, XC1CSK
 ☆ Oil Fill Service Kit, XC1VFK

Repair Parts List, Fig. 1

L4006

Item	Part Number	Qty.	Description	Item	Part Number	Qty.	Description
102	◆ DD4112009	1	Plug, 28 mm (XC-1200)	111	◆ DC7887026	1	Label, Read Instructions
103	◆ DD4110009	1	Dome Plug, 19 mm	114	DD3418528	1	Strap, Shoulder
106	☆ DD3948006	1	Plug, SAE #6 Int. Hex.	115	R515245-2	1	Plug (XC-1200)
107	◆ DD3410026	1	Decal, Product Spec XC	115	R515245-2	2	Plug (XC-1400)
108	◆ DD3409026	1	Decal, Enerpac XC	116	◆ DD4023026	1	Decal, XC Classic 1L
109	◆ DD3937026	1	Decal, "A", XC Pump	116	◆ DD4241026	1	Decal, XC Classic 2L
110	◆ DD3938026	1	Decal, "T", (XC-1200)				
	◆ DD5577026	1	Decal, "B", (XC-1400)				

IMPORTANT: Shaded items are available only in kits (not sold separately).

Fig. 2, Pump LH Shroud & Hardware

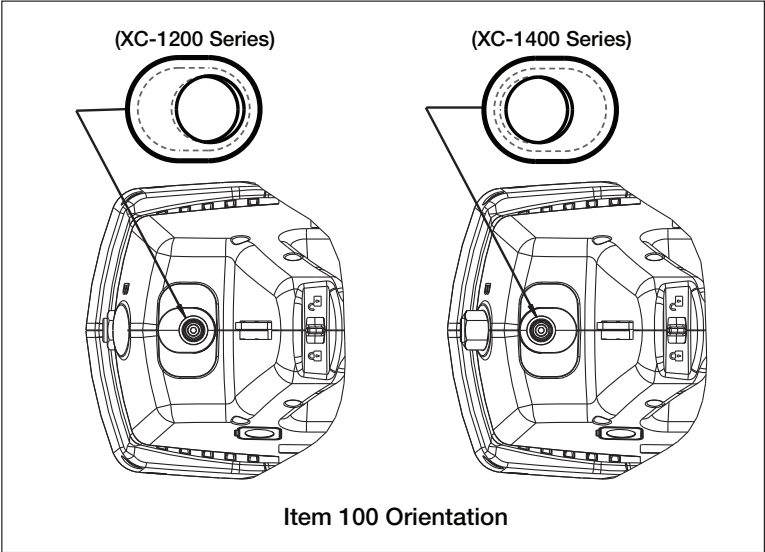
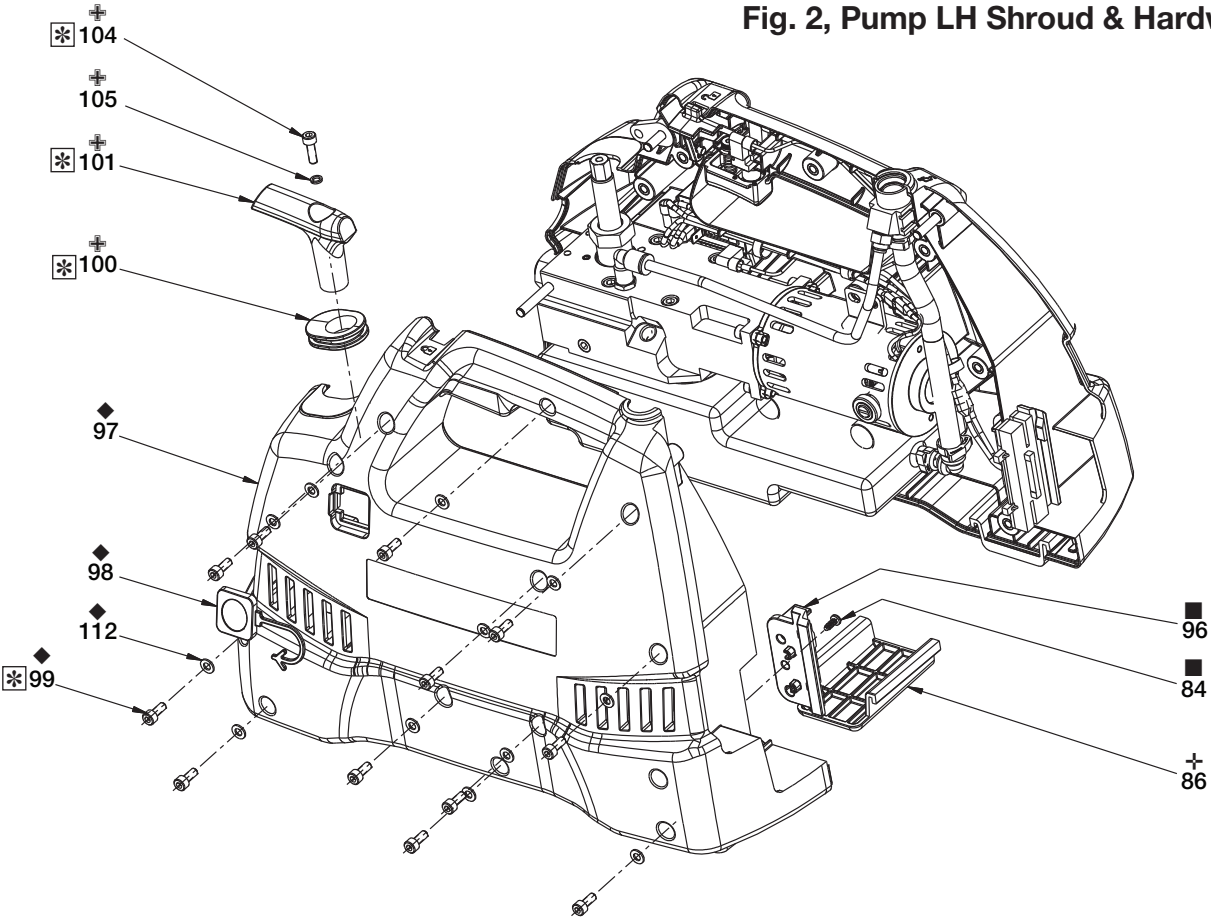

- Item included in:
- ◆ Shroud Kit, XC1CSK
 - ⊕ Rubber Foot Kit, XC1FK
 - Battery Guide Kit, XC1BGK
 - ⊕ Handle Kit, XC1VHK



Repair Parts List, Fig. 2

L4006

Item	Part Number	Qty.	Description	Item	Part Number	Qty.	Description
84	■ DD3883028	1	Screw, M4 x 10 TRX	100	⊕ DD3888808	1	Grommet, Valve
86	⊕ DD3414339	2	Foot, Rubber	101	⊕ DD3398070	1	Handle
96	■ DD3420101	1	Battery Plate, LH	104	⊕ CBE517028-1A	1	Screw
97	◆ DD3405424	1	Shroud, LH	105	⊕ B1086066	1	Washer
98	◆ DD3408098	1	Cap, UARV	112	◆ CAE1050108-1A	12	Washer
99	◆ CBE517028-1A	12	SHCS, M5 x 12 Zinc				

IMPORTANT: Shaded items are available only in kits (not sold separately).

Fig. 3A, Pump RH Shroud & Electrical Components

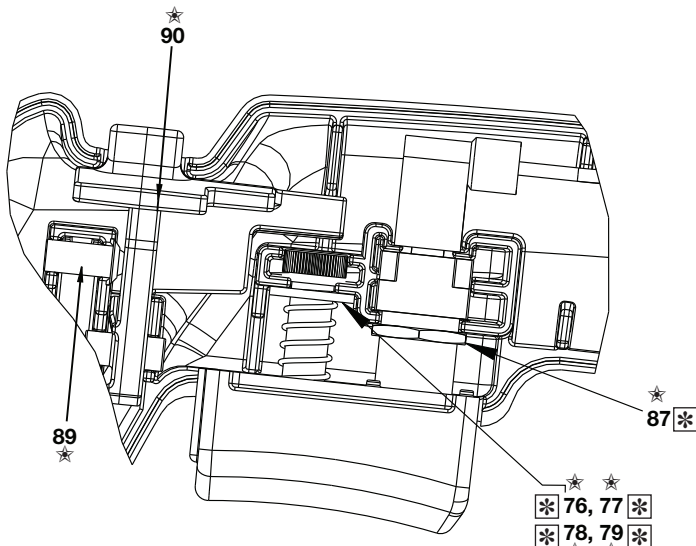

DETAIL "A" - SWITCH AND TRIGGER

Item included in:

- + Rubber Foot Kit, XC1FK
- ★ Trigger Assembly, XC1TRK
- ◆ Shroud Kit, XC1CSK
- Battery Guide Kit, XC1BGK
- ⊕ Motor Brush Kit, XC1MBK
- ⊗ Harness & Relay Kit, DD6094380K

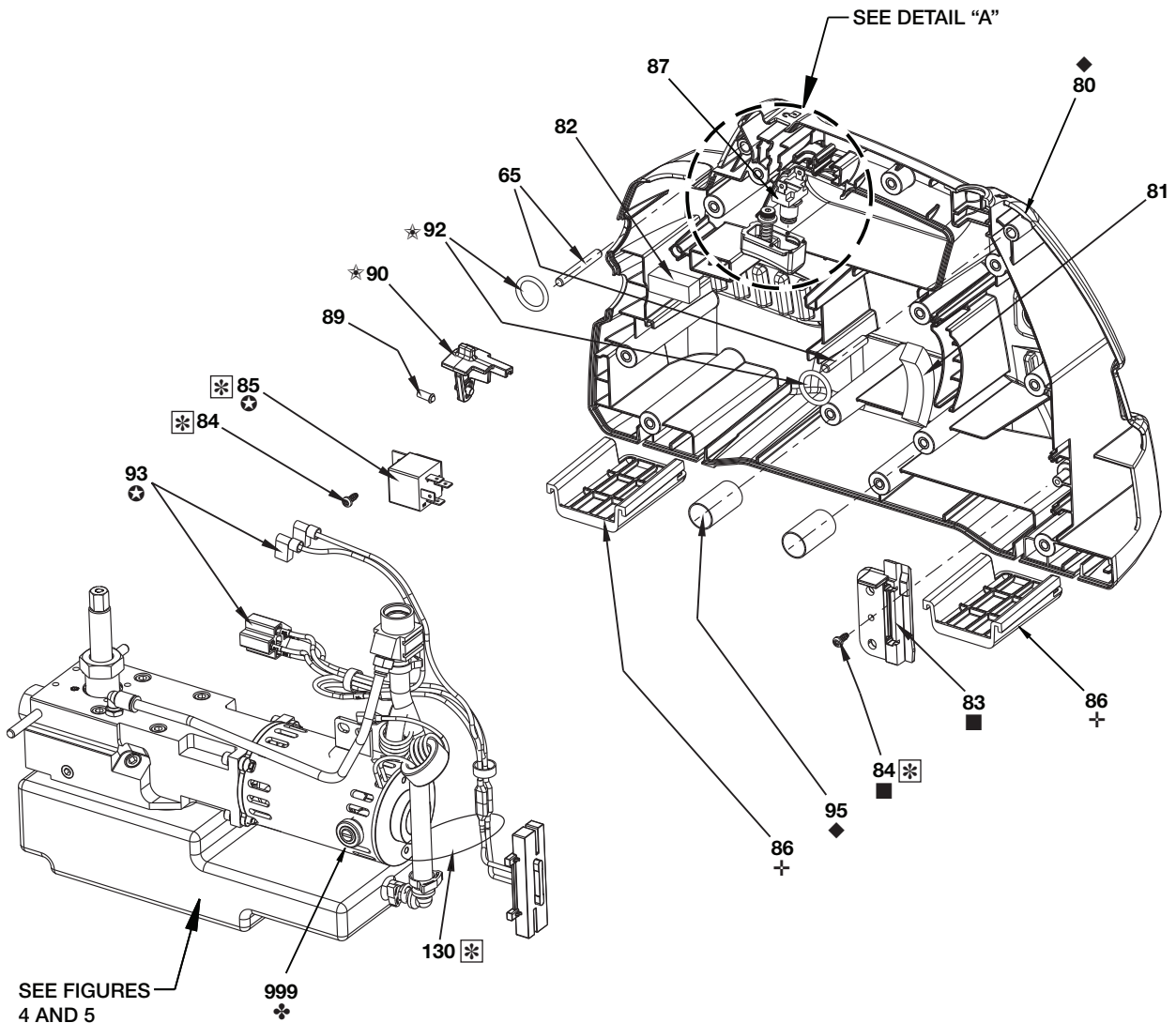

Repair Parts List, Fig. 3A			L4006
Item	Part Number	Qty.	Description
65	DD3417059	2	Pin, 6 mm x 45 mm Long
76	★ DD4114098	1	Cover, Trigger Switch (with insert)
77	★ DD3407110	1	Spring, Trigger
78	★ B1088108	1	Washer
79	★ DD4109028	1	Screw, Shoulder, 0.25 Dia.
80	◆ DD3406424	1	Shroud, RH
81	DD4113339	2	Bumper, Motor Isolator (one per shroud)
82	DD3887339	2	Bumper, Pump Isolator (one per shroud)
83	■ DD3426101	1	Guide, RH Battery Lock
84	■ DD3883028	1	Screw (secures item 83 to RH shroud)
84	DD3883028	1	Screw (secures item 85 to RH shroud)
85	⊕ DD6094380	1	Relay, 60 Amp, 24VDC
86	† DD3414339	2	Foot, Slide
87	★ DD3423379	1	Switch, On-Off, Momentary
89	★ DD3421013	1	Safety Detent
90	★ DD2998098	1	Safety Switch
92	DD4769667	2	Ring, Round
93	⊗ DD6095960	1	Wiring Harness
95	◆ DD3886268	2	Sleeve
130	DC9876647	1	Cable Tie, 6"
999	❖ Order Kit XC1MBK	1	Motor Brush Kit (each kit includes two brushes and two brush caps)

IMPORTANT: Shaded items are available only in kits (not sold separately).

Fig. 3B, Electrical Components, Old Style
(originally installed on pumps with date codes "A" and "B")

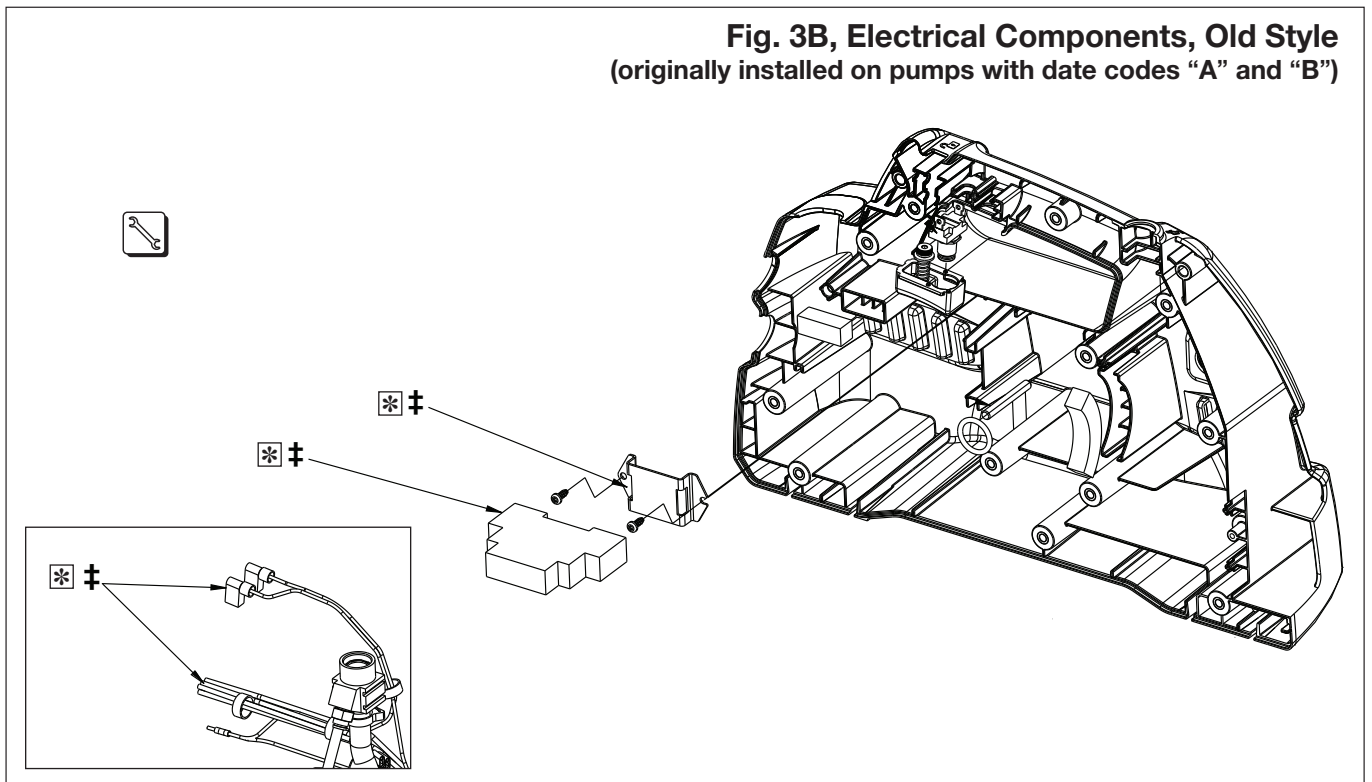
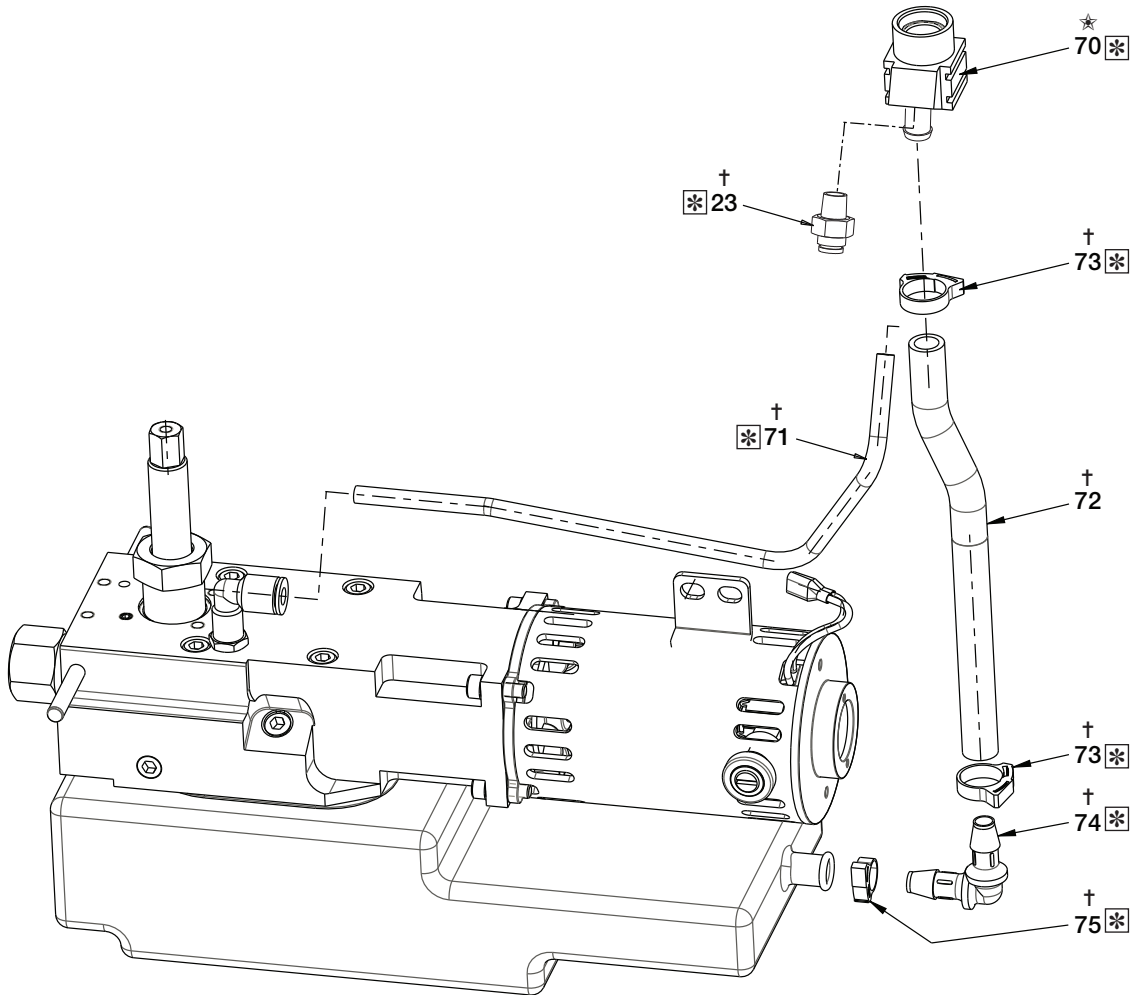

Fig. 4, Oil Fill & Vent Lines

Item included in:

- † Oil Fill Tubing Kit, XC1TK
- ★ Oil Fill Service Kit, XC1VFK



Repair Parts List, Fig. 4

L4006

Item	Part Number	Qty.	Description	Item	Part Number	Qty.	Description
23	† F100097-33	1	Fitting	73	† DD4118017	2	Clip, Oil Fill, Reusable
70	★ DD3403900	1	Fill Assembly, Vented	74	† DD3416097	1	Elbow, Barbed 0.38"
71	† DD4108646	1	Tube, Oil Vent	75	† DD3885017	1	Clip, Reusable 0.38"
72	† DD3415646	1	Tube, Oil Fill				

IMPORTANT: Shaded items are available only in kits (not sold separately).

Fig. 5, Power Unit Assembly

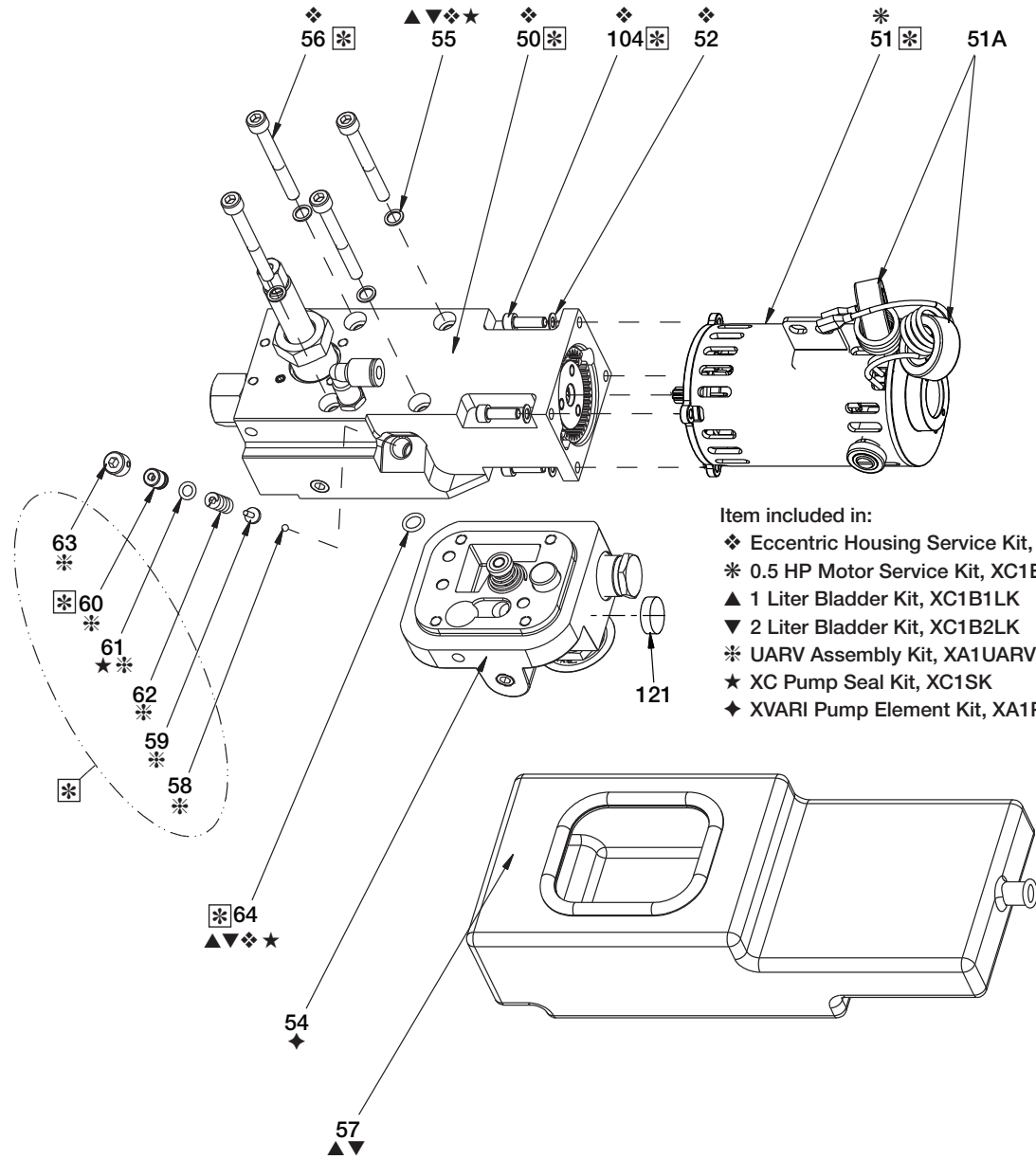

- Item included in:
- ◆ Eccentric Housing Service Kit, XC1ECK
 - * 0.5 HP Motor Service Kit, XC1EMK
 - ▲ 1 Liter Bladder Kit, XC1B1LK
 - ▼ 2 Liter Bladder Kit, XC1B2LK
 - * UARV Assembly Kit, XA1UARVK
 - ★ XC Pump Seal Kit, XC1SK
 - ◆ XVARI Pump Element Kit, XA1PEK

Repair Parts List, Fig. 5							L4006
Item	Part Number	Qty.	Description	Item	Part Number	Qty.	Description
50	(See Fig. 6)	1	(not sold as subassembly)	58	* B1003016	1	Ball, 1/8" Diameter
51	* DD2993259	1	Motor, PMDC 28VDC	59	* A8038570	1	Ball Cap
51A	DD4406380	1	Cores (included with 51)	60	* DC7234009	1	Plug
52	◆ CCE1050108-6A	4	Lock Washer	61	*★ B1004503	1	O-Ring
54	◆ (See Fig 11)	1	Pump Element	62	* A8126110	1	Spring, Coil, 2000 lbs.
55	▲▼◆★ S3037	4	Gasket	63	* DC10131048	1	Set Screw, Cup Pt. Nylok
56	◆ CCA635028-1A	4	Screw, SHCS M6 x 55	64	▲▼◆★ B1011803	1	O-Ring
57	▲ DD2995025	1	Bladder, 1 Liter	104	◆ CBE519028-1A	4	Capscrew
	▼ DD2991025	1	Bladder, 2 Liter	121	C187018	1	Magnet

IMPORTANT: Shaded items are available only in kits (not sold separately).

**Fig. 6, Release Valve & Eccentric Assembly
(XC-1200 Models Only)**

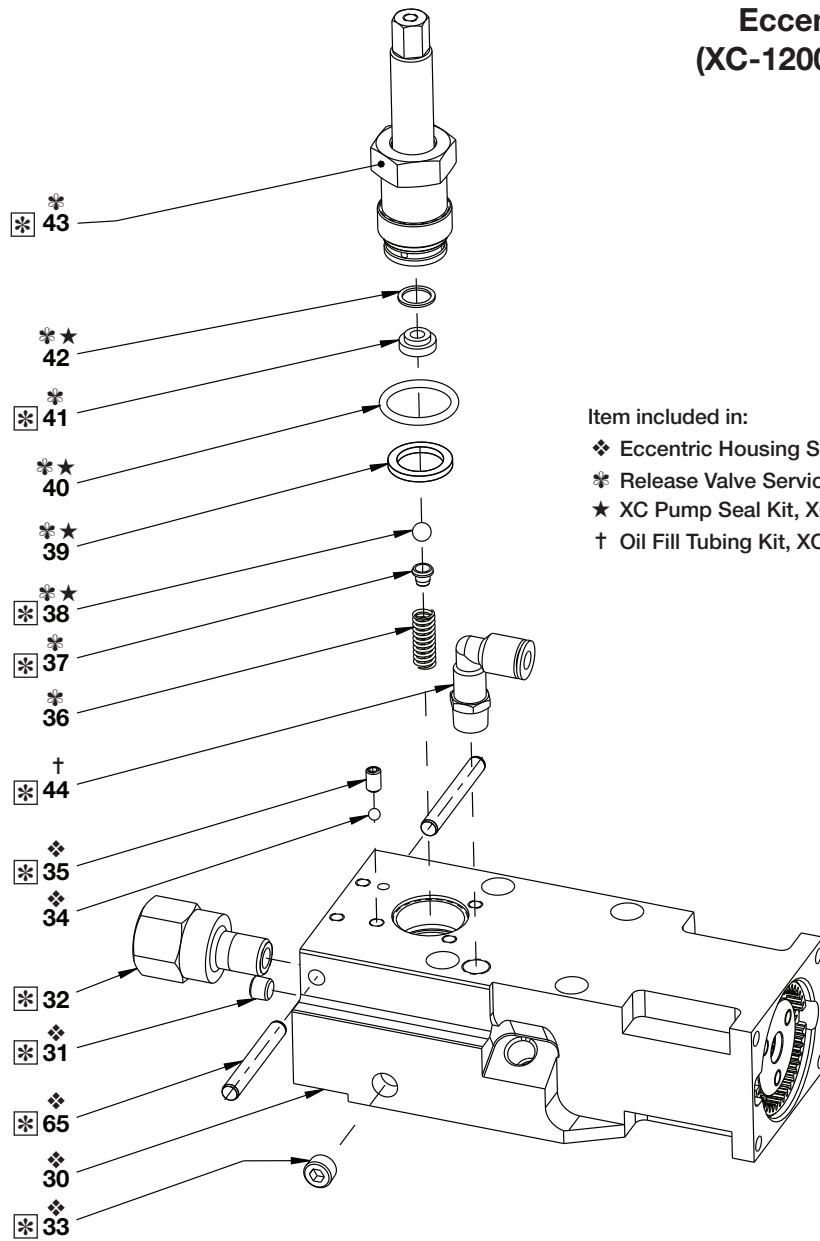

Item included in:

- ❖ Eccentric Housing Service Kit, XC1ECK
- * Release Valve Service Kit, XC1MVSK
- ★ XC Pump Seal Kit, XC1SK
- † Oil Fill Tubing Kit, XC1TK

Repair Parts List, Fig. 6

L4006

Item	Part Number	Qty.	Description	Item	Part Number	Qty.	Description
30	❖ (See Fig. 8)	1	Eccentric and Housing	38	*★ B1007016	1	Ball, 1/4" Dia.
31	❖ DC6792245	1	Plug, Flush NPTF .062	39	*★ CL344167	1	Gasket
32	FZ1055	1	Adapter	40	*★ B1118903	1	O-Ring
33	❖ DC6793245	1	Plug, Flush NPTF .125	41	* DC7305290	1	Seat
34	❖ B1004016	1	Ball, 5/32" Dia.	42	*★ P20037	1	Gasket
35	❖ CCA513028-5A	1	Screw, M5 x 8mm Flat Pt.	43	* (See Fig. 7)	1	Release Valve Subass'y
36	* DC10140110	1	Spring, Compression	44	† F100097-52	1	Elbow
37	* DC7309013	1	Ball Guide	65	❖ DD3417059	2	Pin, 6mm x 45mm Long

IMPORTANT: Shaded items are available only in kits (not sold separately).

**Fig. 7, Release Valve Subassembly
(XC-1200 Models Only)**

Item included in:

- * Release Valve Service Kit, XC1MVSK
- ★ XC Pump Seal Kit, XC1SK

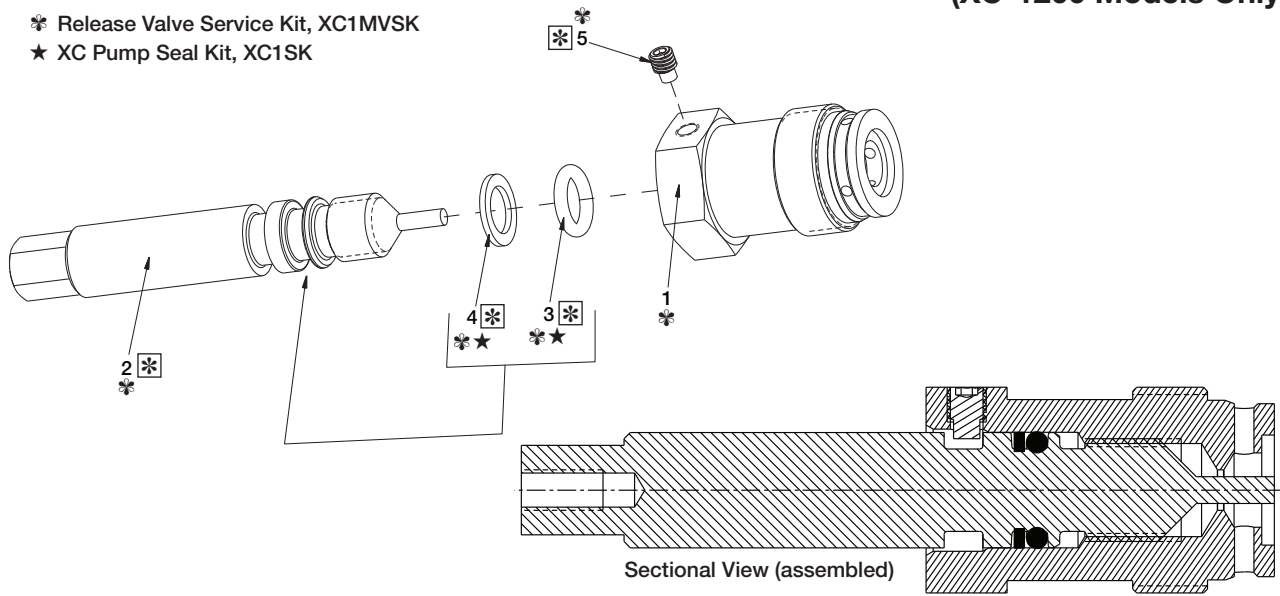

Repair Parts List, Fig. 7

L4006

Item	Part Number	Qty.	Description	Item	Part Number	Qty.	Description
1	* DD2988013	1	Body, Release Valve	4	*★ B1110564	1	Back-Up, Teflon
2	* DD2992010	1	Spindle, Release Valve	5	* DD3400027	1	Set Screw
3	*★ B1110203	1	O-Ring, Viton				

IMPORTANT: Shaded items are available only in kits (not sold separately).

**Fig. 8, Control Valve,
4-Way, 3-Position
(XC-1400 Models Only)**

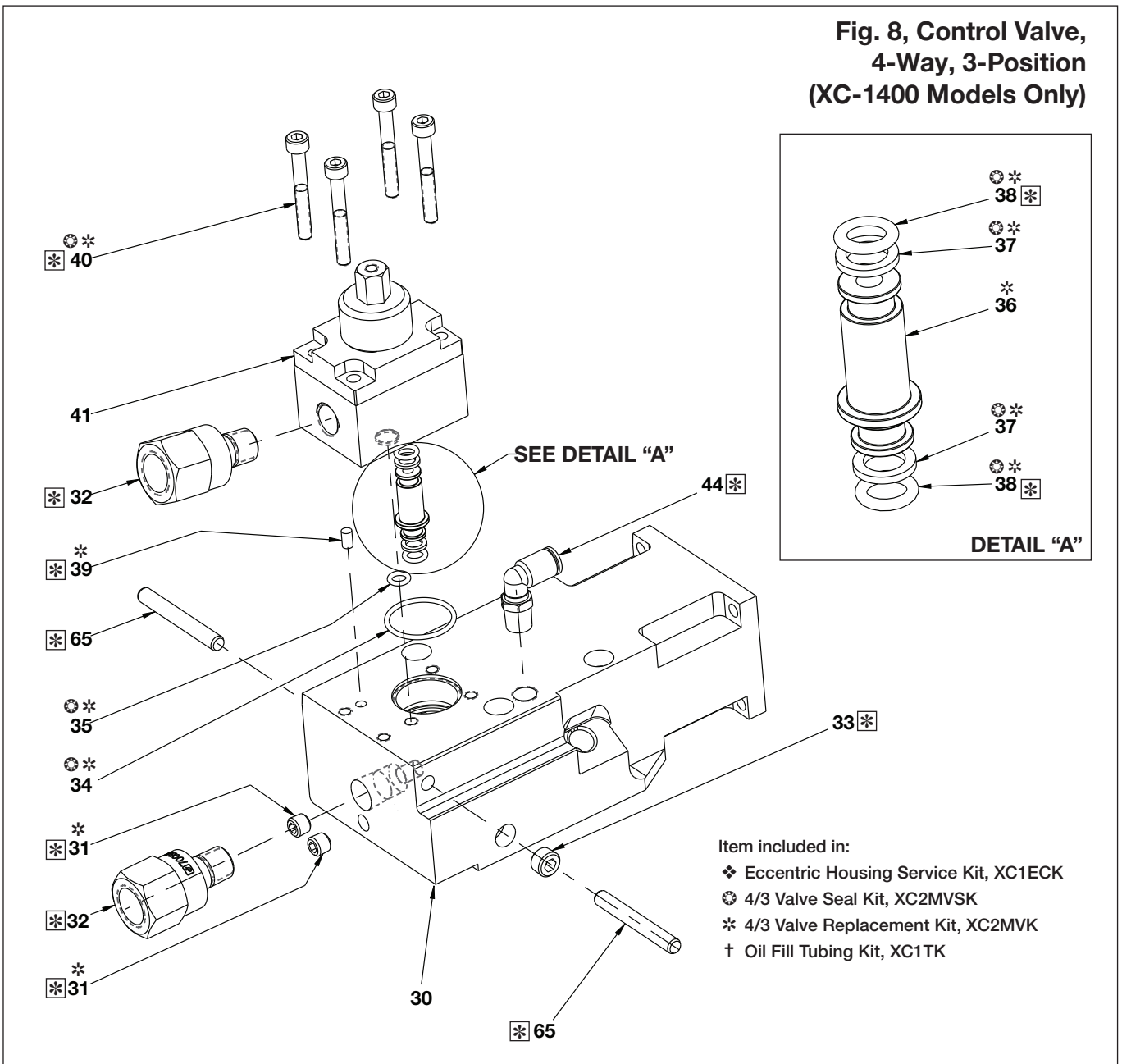

Repair Parts List, Fig. 8

L4006

Item	Part Number	Qty.	Description
30	❖ (See Fig. 8)	1	Eccentric and Housing
31	❖ * DC6792245	1	Flush Plug, .062PTF_SAE
32	CF927038	1	Adaptor
33	❖ DC6793245	1	Plug, Flush NPTF .125
34	⊗ * B1227503	1	O-Ring 70 Duro -021
35	⊗ * B1009803	1	O-Ring, .22, x .34 x 06)
36	* DD2996268	2	Transfer Tube, 4/3 Valve XC
37	⊗ * B1010566	2	Teflon Washer
38	⊗ * B1005503	2	O-Ring
39	⊗ * CAA411061-2B	1	Dowel Pin, 4mm Dia. x 8mm Lg.
40	⊗ * CCA529028-1A	1	Screw, SHCS 5 x 40 CLS 12.9 Din 912
41	DD5253900	1	Valve Assembly, 4-Way, 3-Position Manual
44	† F100097.52	1	Elbow
65	❖ DD3417059	1	Pin, 6mm x 45mm Long

IMPORTANT: Shaded items are available only in kits (not sold separately).

**Fig. 9, Control Valve,
4-Way, 3-Position
(XC-1400 Models Only)**

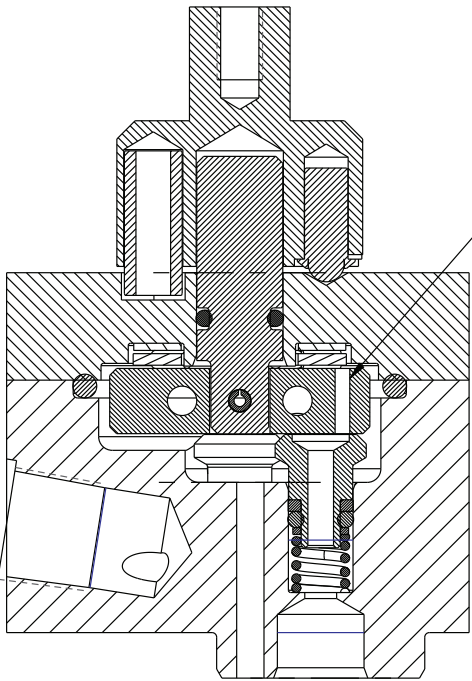
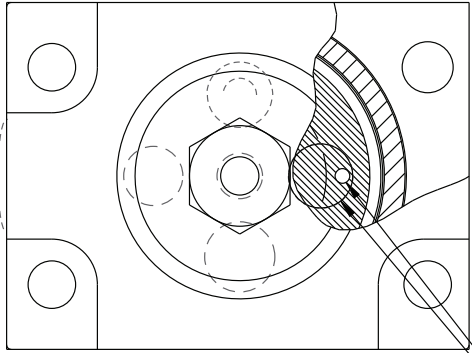

**ORIENT HOLES
AS SHOWN**

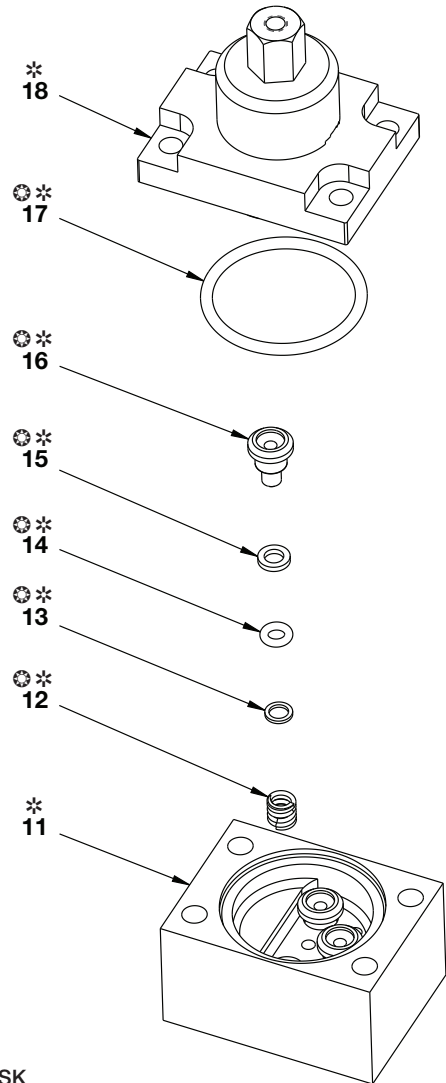

Item included in:
 ⦿* 4/3 Valve Seal Kit, XC2MVSK
 * 4/3 Valve Replacement Kit, XC2MVK

Repair Parts List, Fig. 9				L4006
Item	Part Number	Qty.	Description	
11	* DD2997840	1	Manifold, 4-Way, 3-Position Valve	
12	⦿* DD4446110	3	Spring, .25" OD, .172" ID	
13	⦿* DD4464108	3	Shim, .171 ID, .241 OD	
14	⦿* B1002503	3	O-Ring	
15	⦿* DA7285566	3	Back-Up Washer	
16	⦿* DA11071041	3	Metal Seal, Poppet	
17	⦿* B1259503	1	O-Ring	
18	* DD5252900	1	Cover Assembly, Valve	
IMPORTANT: Shaded items are available only in kits (not sold separately).				

**Fig. 10, Valve Cover Assembly,
4-Way, 3-Position Control Valve
(XC-1400 Models Only)**

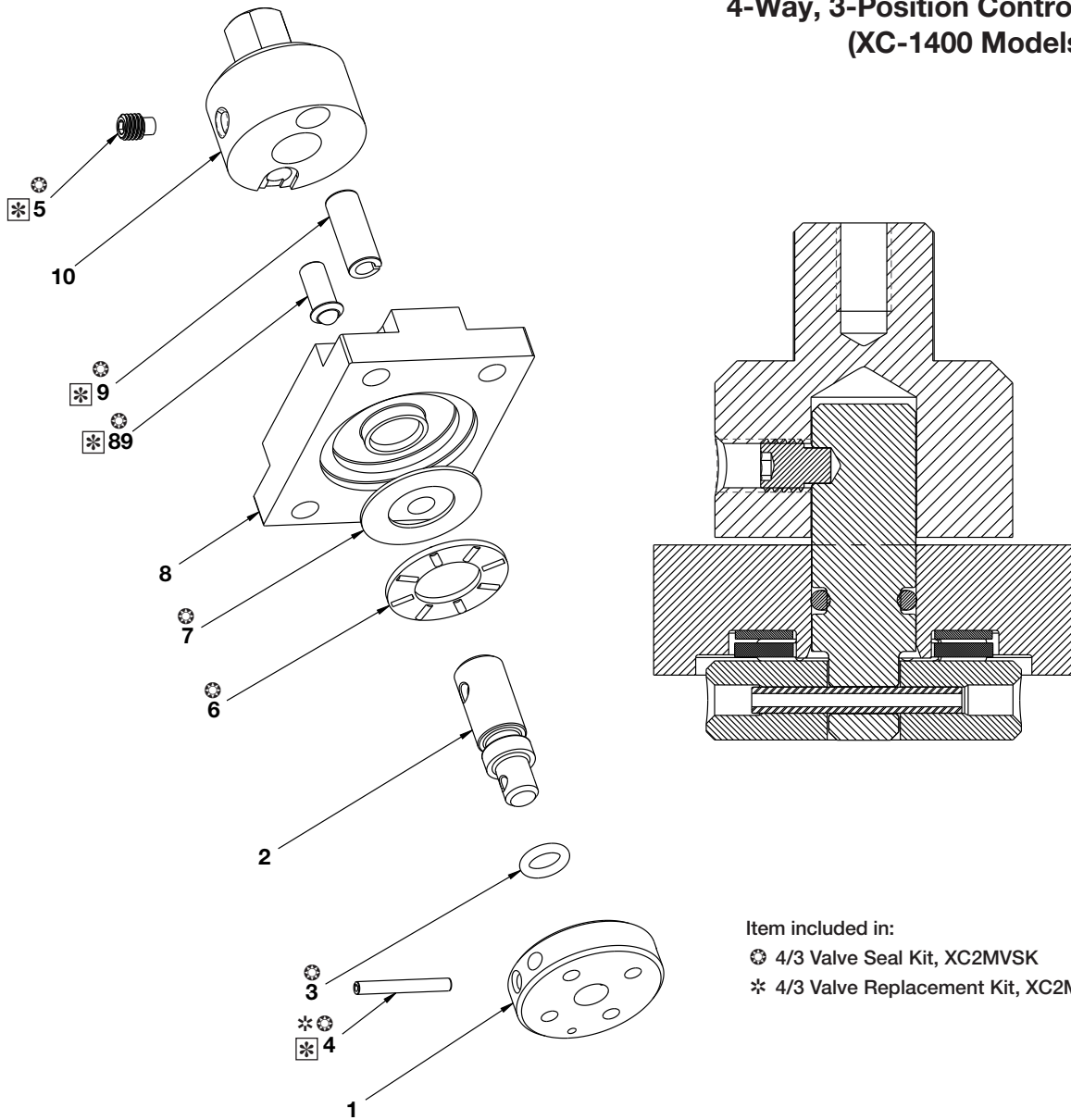

Repair Parts List, Fig. 10

L4006

Item	Part Number	Qty.	Description
01	DA7289900	1	Assembly, Plug and Disc
02	DD4470104	1	Shaft, Valve
03	● B1005503	1	O-Ring
04	*● B1040057	1	Spring Pin
05	● DD3400027	1	Set Screw, 10-32 x .25 Long Pt.
06	● CB183155	1	Needle Bearing
07	● CB184155	1	Thrust Race
08	DD4443098	1	Cover, Valve
09	B1126057	1	Roll Pin
10	DD2999489	1	Collar
89	● DD3421013	1	Detent, Safety Lock XB

IMPORTANT: Shaded items are available only in kits (not sold separately).

**Fig. 11, Eccentric Shaft
& Housing Subassembly**

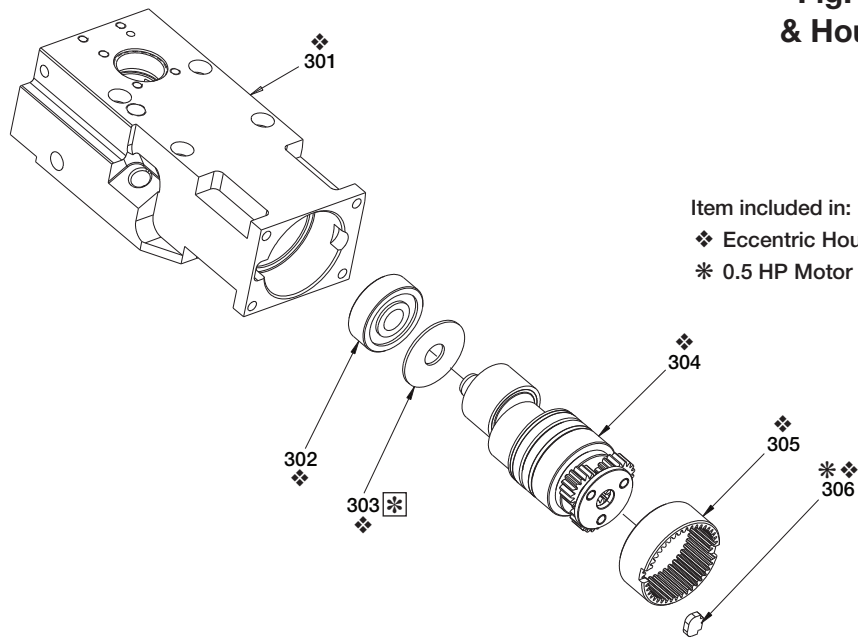

Item included in:

- ❖ Eccentric Housing Service Kit, XC1ECK
- * 0.5 HP Motor Service Kit, XC1EMK

Repair Parts List, Fig. 11

L4006

Item	Part Number	Qty.	Description	Item	Part Number	Qty.	Description
301	❖ DD2989001	1	Housing, Eccentric	304	❖ (See Fig. 9)	1	Assy, Eccentric Shaft
302	❖ DC7096155	1	Bearing	305	❖ DC7089228	1	Inner Gear
303	❖ DC7464108	1	Bushing 12 x 37 x 1.5	306	*❖ DC7452251	1	Key, Gear Ring

IMPORTANT: Shaded items are available only in kits (not sold separately).

Fig. 12, Eccentric Shaft Subassembly

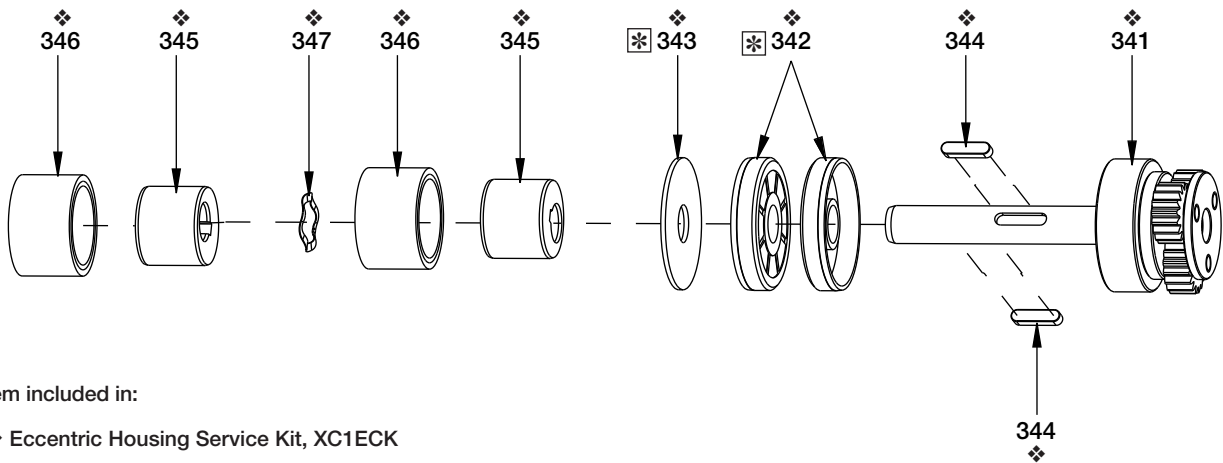

Repair Parts List, Fig. 12

L4006

Item	Part Number	Qty.	Description	Item	Part Number	Qty.	Description
341	❖ DC7870950	1	S/A, Eccentric Shaft	345	❖ DC7117537	2	Eccentric
342	❖ DC7090476	2	Lip Seal	346	❖ DC7755950	2	Subassembly, Cam
343	❖ DC7186108	1	Washer, Thrust	347	❖ DC7750410	1	Spring, Wave
344	❖ DC7191251	2	Key				

IMPORTANT: Shaded items are available only in kits (not sold separately).

Fig. 13, Pump Assembly

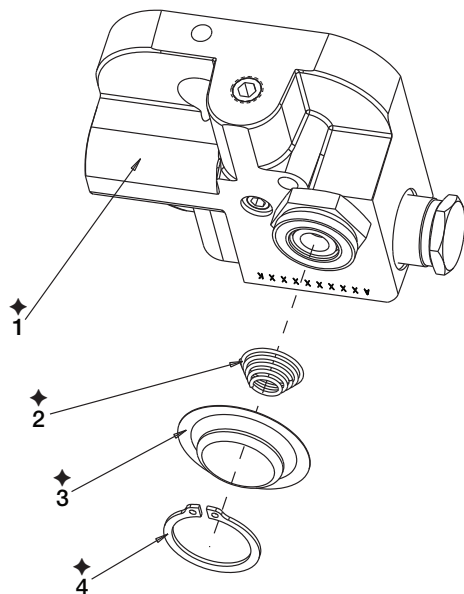

Item included in:
 ◆ XVARI Pump Element Kit, XA1PEK

Repair Parts List, Fig. 13

L4006

Item	Part Number	Qty.	Description
1	◆ DC7206950	1	Assy, Pump Element (See Fig. 11)
2	◆ BSS5509D	1	Spring
3	◆ DC7152018	1	Screen
4	◆ CCA1025044-1A	1	Ring, Retaining

IMPORTANT: Shaded items are available only in kits (not sold separately).

Fig. 14, Pump Element

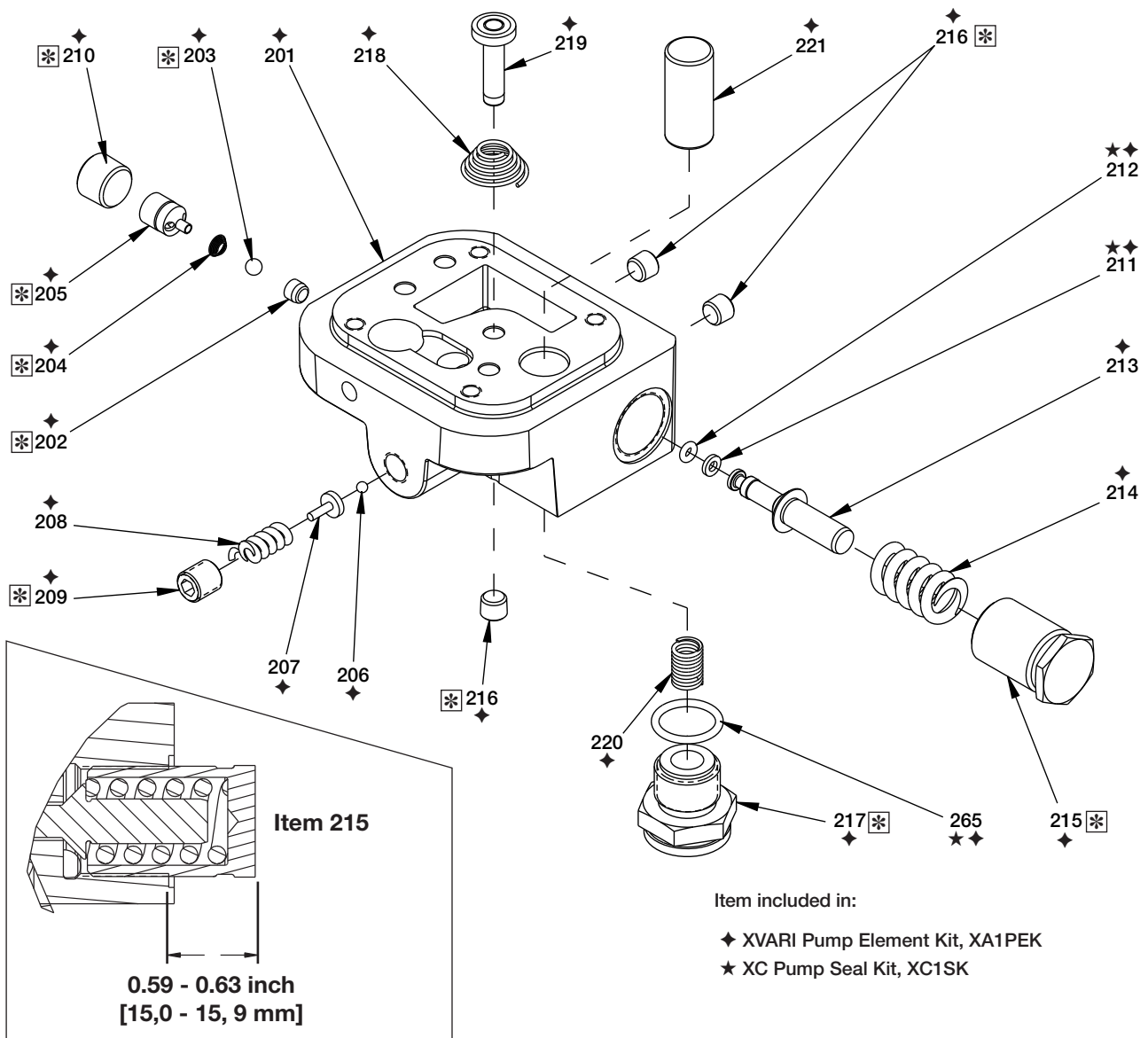

Repair Parts List, Fig. 14

L4006

Item	Part Number	Qty.	Description	Item	Part Number	Qty.	Description
201	◆ DC7201190	1	Body, Pump	212	★◆ B1006803	1	O-Ring, 0.25" O.D.
202	◆ BSS5358D	1	Ball Seat, Inlet	213	◆ DC9292051	1	Piston, Bypass
203	◆ B1005016	1	Ball, 3/16" Dia.	214	◆ DC394110	1	Spring, Bypass
204	◆ BSS5809D	1	Spring	215	◆ DC9208020	1	End Cap, Bypass
205	◆ DC7904900	1	Assy, Outlet Check	216	◆ A1006245	3	Plug, Flush 1/16"
206	◆ B1003016	1	Ball, 1/8" Dia	217	◆ DC7453950	1	Assembly, Inlet Check
207	◆ A8038570	1	Ball Cap	218	◆ BSS5509D	1	Spring, Conical
208	◆ A8126110	1	Spring	219	◆ DC9244920	1	Piston, 6 mm Dia
209	◆ DC1185048	1	Soc. Hd. Set Scw., Hollow	220	◆ DC7026110	1	Spring, Large Piston
210	◆ DC6794245	1	Plug, NPTF 1/4"	221	◆ DC7027051	1	Piston, 14 mm Dia
211	★◆ B1006564	1	Washer, B/U	265	★◆ B1908503	1	O-Ring

IMPORTANT: Shaded items are available only in kits (not sold separately).

Fig. 15, Battery & Charger

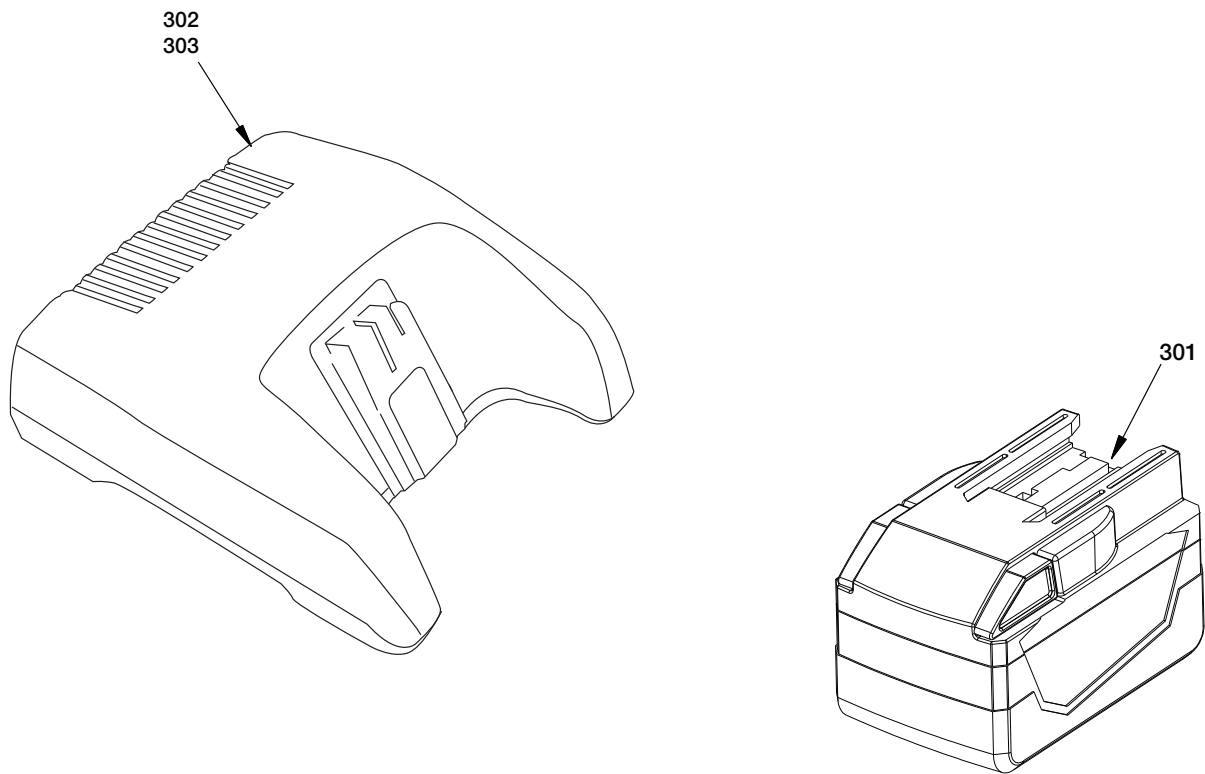

Repair Parts List, Fig. 15			L4006
Item	Part Number	Qty.	Description
301	XC28V	1	Battery, 28 Volt Li-Ion
302	XC115VC	1	Battery Charger, 115 VAC input
303	XC230VC	1	Battery Charger, 230 VAC input

Note: "M28™" and the Milwaukee Electric Tool logo are trademarks and intellectual property of Milwaukee Electric Tool Corporation. Exact appearance of battery and charger may vary.

**Fig. 16A, Electrical Schematic
(Models with date codes "A" and "B")**

⚠ WARNING Remove battery and disconnect hydraulic hoses before beginning any maintenance or repairs.

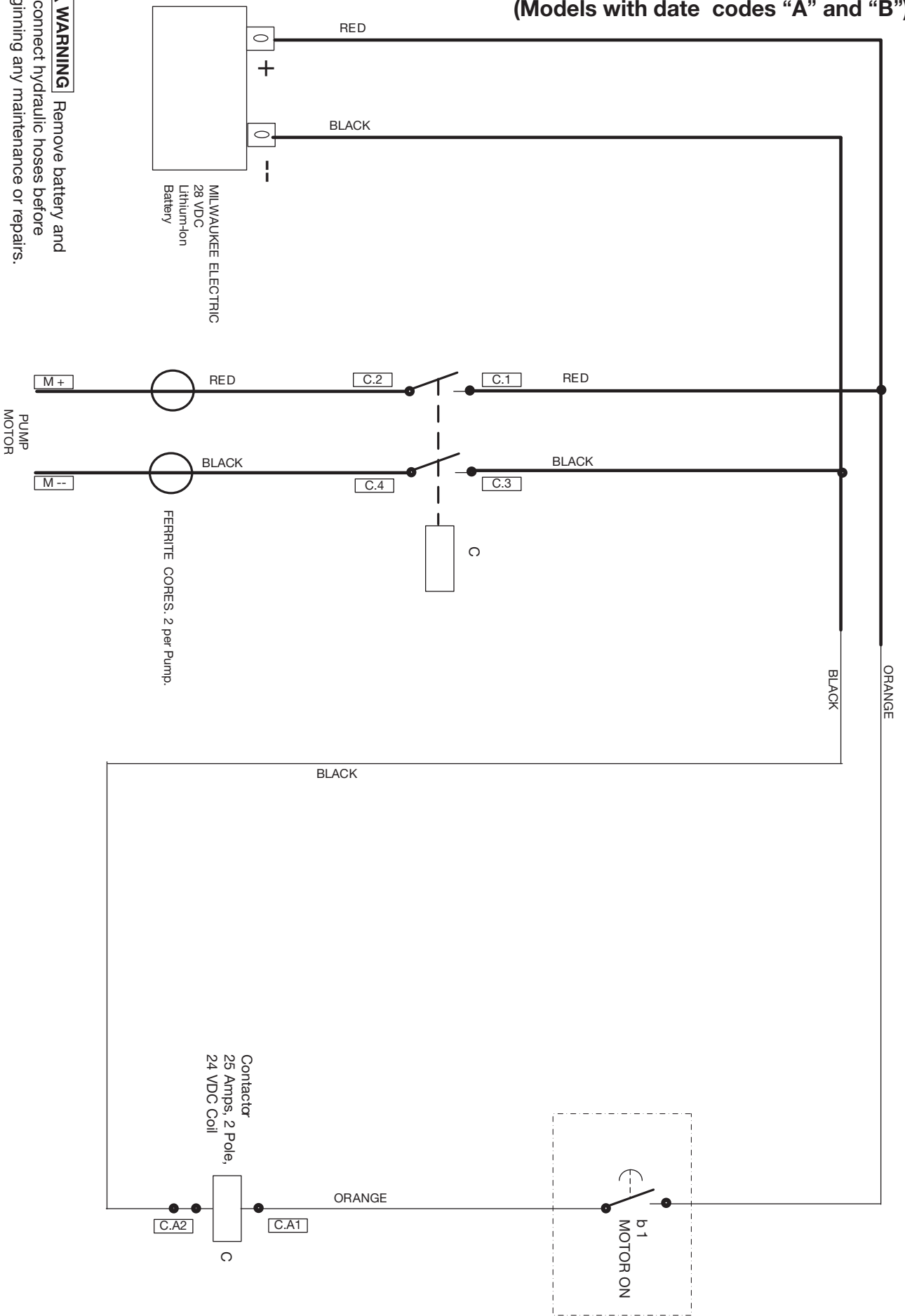

**Fig. 16B, Electrical Schematic
(Models with date code "C")**

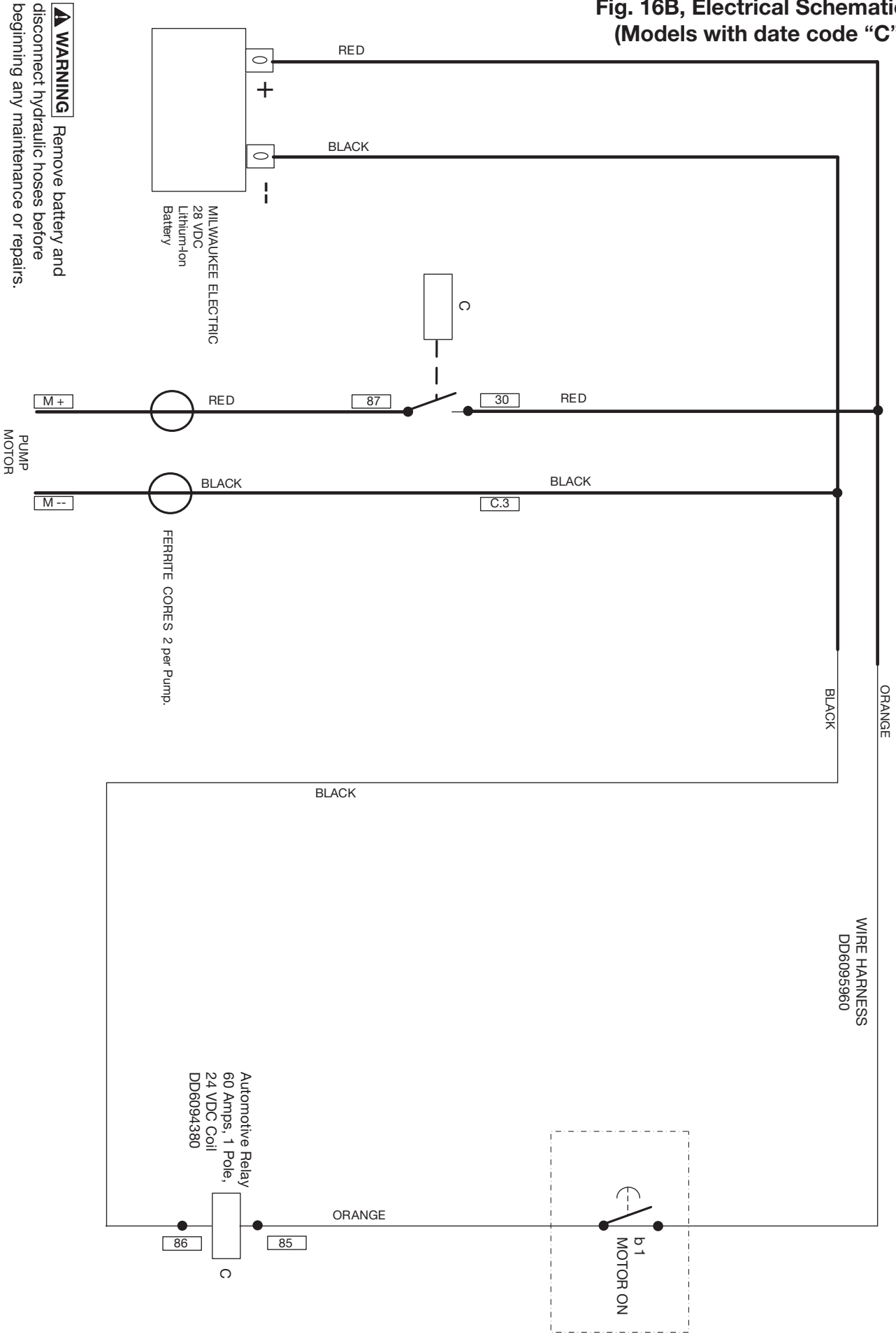



* Service Information		L4006
Fig.	Item	Torque / notes
1	106	4,5 - 5,7 Nm [40 - 50 In - Lbs.]
1	107	Apply self adhesive label. Locate as shown.
1	108	Apply self adhesive label. Locate as shown.
1	109	Apply self adhesive label. Locate as shown.
1	110	Apply self adhesive label. Locate as shown.
1	111	Apply self adhesive label. Locate as shown.
1	115	13,6 - 16,3 Nm [10 - 12 Ft - Lbs]
1	115	When loosening plug (Fig. 1, item 115), use a second wrench to prevent adapter fitting (Fig. 6, item 32) from turning.
2	84	0,9 - 1,1 Nm [8 - 10 In - Lbs]
2	97	No gap between LH and RH shroud halves when assembled.
2	99	2 - 3 Nm [18 - 26 In - Lbs]
2	100	Be sure that item 100 is properly oriented for your pump model. See diagram at bottom of Fig. 2.
2	101	Before installing handle, rotate valve clockwise until it stops.
2	104	Apply Loctite 243.
2	104	2 - 3 Nm [18 - 26 In - Lbs]
3A	76, 77, 78 & 79 and Detail A	Assemble washer and spring below tab in housing.
3A	80	No gap between LH and RH shroud halves when assembled.
3A	84	0,9 - 1,1 Nm [8 - 10 In - Lbs]
3A	85	Orient as shown.
3A	87	Apply Loctite 2760.
3A	87	Install switch mounting nut finger tight on shroud rib, then remove and screw nut on 1/2 turn. Reinstall.
3A	130	Secure cables with wire ties.
3B	‡	Old style relay, bracket and wiring harness (parts marked with ‡) are no longer available. Order harness and relay kit, DD6094380K if replacement is necessary. Replace both wiring harness and relay as a set. Old relay mounting plate is no longer needed and can be discarded. Refer to Figure 3A for new parts arrangement.
4	23	Torque to 4,0 - 5,6 Nm [36 - 50 In - Lbs]
4	70	Apply grease as required when assembling tubes to fitting.
4	71	Push to connect.
4	73	Squeeze until tight.
4	74	Apply grease as required when assembling tube to fitting.
4	75	Squeeze until tight.
5	50, 51	Apply grease to ring gear teeth before installing motor.
5	51	Orient with tab UP.
5	51A	Ferrite cores (item 51A) are included with motor (item 50).
5	104	Apply Loctite 243.
5	104	5,3 - 7,6 Nm [45 - 60 In - Lbs]
5	56	Apply Loctite 2760.
5	56	17,0 - 20,5 Nm [12 - 15 Ft - Lbs]
5	58 - 63	Install last - after pump, bladder and motor.
5	60	Plug includes M4 tapped hole. Remove using M4 screw.
5	64	Install on eccentric housing.

(Continued on next page.)



* Service Information (Continued)		L4006
Fig.	Item	Torque / notes
6	31	Apply Teflon tape to threads.
6	31	13,5 - 16,3 Nm [10 - 12 Ft - Lbs]
6	32	Apply Teflon tape to threads.
6	32	43 - 53 Nm [32 - 39 Ft - Lbs]
6	33	Apply Teflon tape to threads.
6	33	22,0 - 25,0 Nm [16 - 19 Ft - Lbs]
6	35	Apply Loctite 243.
6	35	4,1 - 6,8 Nm [36 - 60 In - Lbs]
6	37	Apply grease to aid assembly.
6	38, 41	Coin seat before installation.
6	43	Apply Loctite 243.
6	43	122,0 - 128,8 Nm [90 - 95 Ft - Lbs] (valve body)
6	44	Apply Teflon tape to threads.
6	44	4,1 - 6,8 Nm [30 - 60 In - Lbs]
6	65	Press fit.
7	2	Turn counter-clockwise to assemble. Turn-in until groove is seen in body through hole.
7	3, 4	Apply grease to O-Ring and back-up after assembly to spindle, before assembly to body.
7	5	Apply Loctite 243.
7	5	2,4 - 3,0 Nm [21 - 26 In - Lbs]
8	31	13,5 - 16,3 Nm [10 - 12 Ft - Lbs]
8	32	Apply Teflon tape to threads.
8	32	43 - 53 Nm [32 - 39 Ft - Lbs]
8	33	22,0 - 25,0 Nm [16 - 19 Ft - Lbs]
8	38	Lubricate seals before assembling them into items 41 and 30.
8	39	Press fit.
8	40	Apply Loctite 243.
8	40	4,6 - 5,4 Nm [55 - 65 In - Lbs]
8	44	Torque to 4,0 - 7,6 Nm [36 - 60 In - Lbs]
8	65	Press fit.
10	1	Orient as shown before assembly.
10	4	Press fit into item 1 when aligned with item 2.
10	5	Apply Loctite 243.
10	5	2,4 - 3,0 Nm [21 - 26 In - Lbs]
10	9	Press fit into item 10.
10	89	Press fit into item 10.

(Continued on next page.)

* Service Information (Continued)		L4006
Fig.	Item	Torque / notes
12	303	Position gray coated side of bushing (item #303) toward eccentric (item #304).
12	342, 343	Position gray coated side of thrust washer (item 343) toward eccentric (item 345).
14	202, 203 204, 205	Outlet check valve components are permanently installed in valve body. These components cannot be removed.
14	209	Set safety relief valve pressure to 711 - 737 Bar [10300 - 10700 Psi].
14	210	Apply Teflon tape to threads.
14	210	60 - 71 Nm [44.2 - 52.3 Ft - Lbs]
14	215	Bypass setting end cap dimension: 15,0 - 15,9 mm [0.59 - 0.63 inch] (measured from counterbore to edge of cap)
14	216	Apply Teflon tape to threads.
14	216	13 - 16 Nm [9.8 - 11.8 Ft - Lbs]
14	217	25 - 30 Nm [18.4 - 22.1 Ft - Lbs]

NOTES:

Enerpac Worldwide Locations

◆ e-mail: info@enerpac.com

◆ internet: www.enerpac.com

Australia and New Zealand

Actuant Australia Ltd.
P.O. Box 6867
Wetherhill Park, NSW 1851
Block V Unit 3
Regents Park Estate
391 Park Road
Regents Park NSW 2143
Australia
T +61 287 177 200
F +61 297 438 648

Brazil

Power Packer do Brasil Ltda.
Rua Luiz Lawrie Reid, 548
09930-760 - Diadema (SP) - Brazil
T +55 11 5687 2211
Toll Free: 0800 891 5770

China (Taicang)

Actuant (China) Industries Co. Ltd.
No.6 Nanjing East Road,
Taicang Economic Dep Zone
Jiangsu, China
T +86 0512 5328 7500
F +86 0512 5335 9690
Toll Free: +86 400 885 0369

France, Switzerland, North Africa and French speaking African countries

ENERPAC
Une division d'Actuant France S.A.S
Zone Orlytech Bâtiment 516
1 allée du commandant Mouchotte
CS 40351
91550 Paray-Vieille-Poste
France
T +33 1 60 13 68 68
F +33 1 69 20 37 50

Germany and Austria

Actuant GmbH
P.O. Box 300113
D-40401 Düsseldorf
Willstätterstrasse 13
D-40549 Düsseldorf, Germany
T +49 211 471 490
F +49 211 471 49 28

India

Actuant India Private Limited
No. 10, Bellary Road, Sadashivanagar,
Bangalore, Karnataka 560 080
India
T +91 80 3928 9000

Italy

ENERPAC S.p.A.
Via Canova 4
20094 Corsico (Milano)
T +39 02 4861 111
F +39 02 4860 1288

Japan

Enerpac Co., Ltd.
Besshocho 85-7
Kita-ku, Saitama-shi 331-0821, Japan
T +81 48 662 4911
F +81 48 662 4955

Middle East, Egypt and Libya

ENERPAC Middle East FZE
Plot M00737m 1242nd Street
Jebel Ali Free Zone North
P.O. Box 18004, Dubai
United Arab Emirates
T +971 (0)4 8872686
F +971 (0)4 8872687

Russia

Rep. office Enerpac
Russian Federation
Admirala Makarova Street 8
125212 Moscow, Russia
T +7 495 98090 91
F +7 495 98090 92

Norway

Sales Office Norway
Unit 524, Nydalsveien 28, 0484 Oslo
P.O. Box 4814, Nydalen 0422 Oslo
Norway
T +47 91 578 300

Southeast Asia, Hong Kong and Taiwan

Actuant Asia Pte Ltd.
83 Joo Koon Circle
Singapore 629109
T +65 68 63 0611
F +65 64 84 5669
Toll Free: +1800 363 7722

South Korea

Actuant Korea Ltd.
3Ba 717, Shihwa Industrial Complex
Jungwong-Dong, Shihung-Shi,
Kyunggi-Do
Republic of Korea 429-450
T +82 31 434 4506
F +82 31 434 4507

Spain and Portugal

ENERPAC SPAIN, S.L.
Avda. Valdelaparra N° 27 3ª - L8
28108 Alcobendas (Madrid), Spain
T +34 91 884 86 06
F +34 91 884 86 11

Sweden, Denmark

Finland and Iceland
Enerpac Scandinavia AB
Kopparlundsvägen 14,
721 30 Västerås
Sweden
T +46 (0) 771 41 50 00

The Netherlands, Belgium, Luxembourg, Central and Eastern Europe, Baltic States, Greece, Turkey and CIS countries

ENERPAC B.V.
Galvanistraat 115, 6716 AE Ede
P.O. Box 8097, 6710 AB Ede
The Netherlands
T +31 318 535 911
F +31 318 535 848

Enerpac Heavy Lifting Technology B.V.

Spinelstraat 15, 7554 TS Hengelo
P.O. Box 421, 7550 AK Hengelo
The Netherlands
T +31 74 242 20 45
F +31 74 243 03 38

South Africa and other English speaking African countries

Enerpac Africa Pty Ltd.
No. 5 Bauhinia Avenue
Cambridge Office Park
Block E
Highveld Techno Park
Centurion 0157
Republic of South Africa
T: +27 12 940 0656

United Kingdom and Ireland

ENERPAC UK Ltd.
5 Coopies Field
Morpeth, Northumberland
NE61 6JR, England
T +44 1670 5010 00

USA, Latin America and Caribbean

ENERPAC World Headquarters
P.O. Box 3241
Milwaukee WI 53201-3241 USA
N86 W12500 Westbrook Crossing
Menomonee Falls, Wisconsin 53051
T +1 262 293 1600
F +1 262 293 7036
User inquiries:
T +1 800 433 2766
Distributor inquiries/orders:
T +1 800 558 0530
F +1 800 628 0490

All Enerpac products are
guaranteed against defects
in workmanship and materials
for as long as you own them.

For the location of your nearest
authorized Enerpac Service Center,
visit us at www.enerpac.com

040717

ENERPAC

Visit www.enerpac.com for the location of the
Enerpac Authorized Service Center nearest you.