

**To Protect Your Warranty, Use Only ENERPAC Hydraulic Oil.**

Enerpac recommends that all kit components be installed to insure optimum performance of the repaired product.

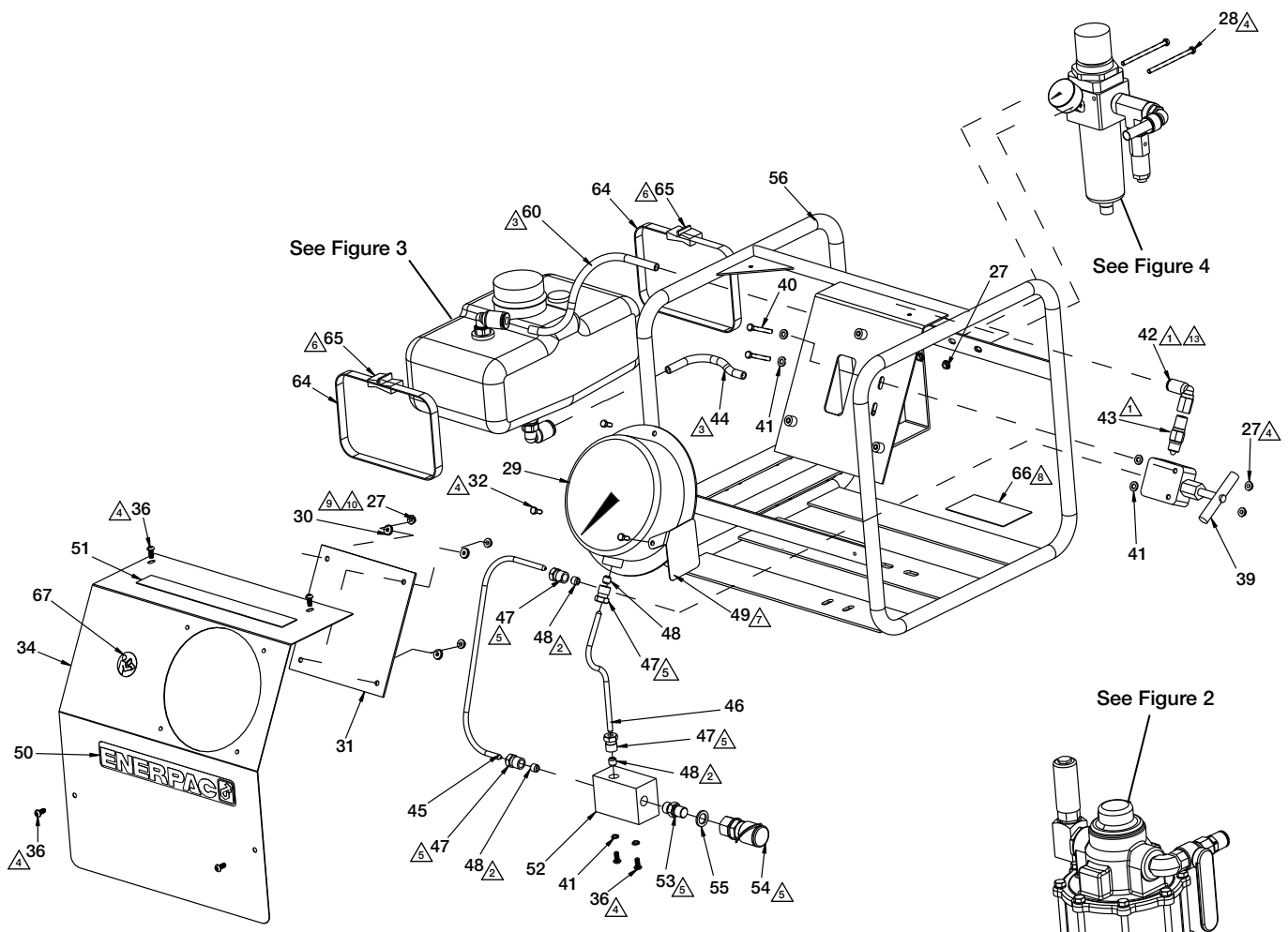



Notes:

- ① Torque to 28-32 ft-lbs [38-43 Nm].
- ② Thread item 48 onto tubing (item 45 or 46) until 1-1/2 to 2 threads on tubing (item 45 or 46) are showing.
- ④ Torque to 20-25 in-lbs [2,2-2,8 Nm].
- ⑤ Torque to 30-35 ft-lbs [40,6-47,0 Nm].
- ⑥ Tighten item 65 using ratchet tool (McMaster Carr #5188K33).
- ⑦ Secure item 49 to gauge flange with item 32.
- ⑧ Remove paper on back of item 66 and secure to item 56.
- ⑨ Torque to 6-10 in-lbs [0,6-1,1 Nm].
- ⑩ Apply Loctite 242 to threads before installation.
- ⑪ Apply Loctite 545 to threads before installation.
- ⑬ Torque to 10-15 ft-lbs [14-20 Nm].

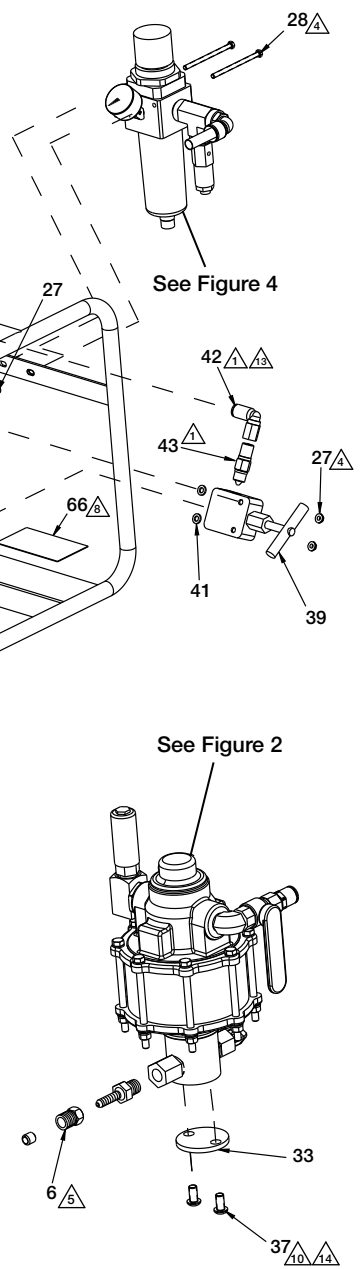
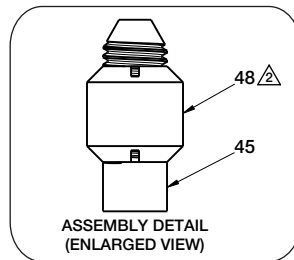

Figure 1, Pump Main Assembly

Repair Parts List (Refer to figure 1)							
Item	Part Number	Qty.	Description	Item	Part Number	Qty.	Description
6	F157021	1	HP Nut, 3/8	45	DD1002268	1	Tubing, High Pressure
27	DD1004122	8	Nut, M5 Serrated	46	DD1003268	1	Tubing, High Pressure
28	CBE543046-1A	2	Screw Hex Hd M5 x 70mm	47	F160021	4	Nut, 1/4 HP
29	DD1018223	1	Gauge, Hyd. Pressure	48	F162232	4	Sleeve, 1/4
30	DC1063108	4	Washer, Sealing	49	DD1006226	1	Label, Operation
31	DD1005689	1	Guard, Hyd. Press. Gauge	50	G995026	1	Decal, Enerpac
32	CBE415028-1A	3	Screw, M4 x 10mm	51	DC7812026	1	Decal, Warning
33	DD1014097	1	Spacer, Celcon (pump)	52	DC8493690	1	Port Block
34	◆ DD1349242	1	Shroud (late style)	53	DC8505038	1	Adaptor
36	CBE515028-1E	6	Screw, M5 Button Head	54	DC7495034	1	Coupler
37	DD1098046	2	Screw, Button Head 3/8	55	DD1017037	1	Bonded Seal
39	DC8508662	1	Pressure Release Valve	56	◆ DD1345101	1	Roll Frame (late style)
40	CBE529046-1A	2	Screw, M5 Hex Head 40mm	60	CM673268	1	Tubing, 3/8 OD (0.9 ft. lg.)
41	CAE1060108-1A	6	Washer, Flat	64	DD1012217	2	Strap (2 ft. lg. each)
42	DD1096095	1	Elbow, 1/4 NPTF x 3/8 OD	65	DD1011299	2	Clamp
43	DC8514038	1	Adaptor, 1/4HP x 1/4NPT	66	DD1015126	1	Nameplate
44	CM673268	1	Tubing 3/8 OD (0.5 ft. long)	67	DC9920026	1	Decal, Read Manual

◆ Pumps with date code "A": Original equipment shroud (item 34) and roll frame (item 56) must be replaced as a set if either component is damaged. Order late style shroud and roll frame. Early style shroud and roll frame not available.

**Notes:**

- △ Apply Loctite 545 to threads.
- △ Torque to 12-14 ft-lbs [14-16 Nm]. Position as shown.
- △ Torque to 68-75 ft-lbs [92-102 Nm].
- △ Torque to hand tight plus 1-1/2 to 2 turns. Position as shown.
- △ Thread item 7 onto item 5 until 1-1/2 to 2 threads show on item 5.
- Note: Items 5 and 7 have left-hand threads.
- △ Apply Teflon tape to threads.

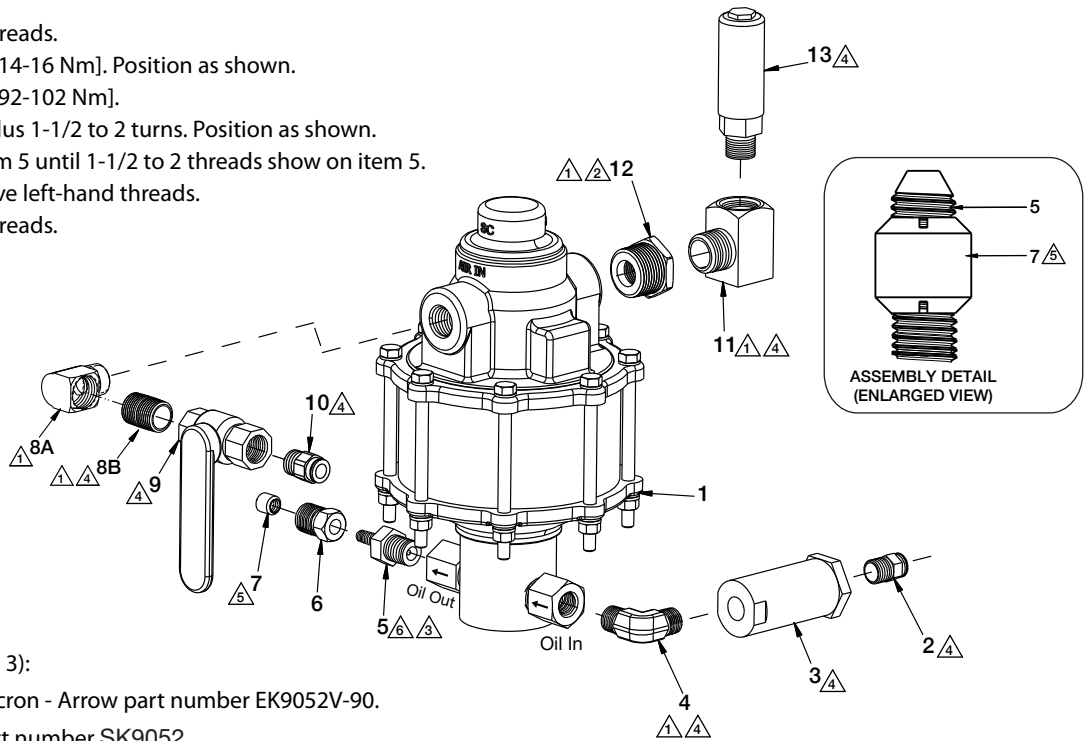

Filter information (item 3):

- Filter Element, 90 micron - Arrow part number EK9052V-90.
- Spring Kit - Arrow part number SK9052.

For ordering information, go to [www.arrowpneumatics.com](http://www.arrowpneumatics.com).

**Figure 2, Pump Element Subassembly**

**Repair Parts List (Refer to figures 2, 3 and 4)**

Item	Part Number	Qty.	Description	Item	Part Number	Qty.	Description
1	★*DC8506221	1	Pump Element Assy	14	DD1001025	1	Reservoir
2	F100094-19	1	Adapter, 3/8 NPT to 3/8 37° Flare	15	DC8507662	1	Shutoff Valve
3	DD1013118	1	Filter, Inline (with element)	16	DC8517095	2	Elbow, Swivel, 3/8 x 3/8 OD
4	CJ456096	1	Elbow, 3/8	17	DC8526118	1	Assembly, Filter-Regulator
5	DC8495097	1	Adaptor	18	A1010245	1	Pipe Plug, 1/2
6	F157021	1	HP Nut, 3/8	19	DD1022095	1	Elbow, 45 degree 1/8
7	F73232	1	Sleeve, 3/8	20	DC8527223	1	Gauge, Air Pressure
8A	DD2604095	1	Elbow, Pipe	22	DC8097095	1	Nipple, 1/2 NPT
8B	DD2603431	1	Nipple, Brass	23	DA1234095	1	Tee, 1/2 NPT
9	DD1010662	1	Valve, Ball	24	DC8511663	1	Safety Relief Valve
10	DD1008095	1	Connector, 1/2 NPT x 1/2 OD	25	DC8509095	1	Elbow, Swivel 1/2 NPT
11	F100095-45	1	Elbow, 3/8	26	DC8520646	1	Tubing, (0.2 ft. long)
12	F100095-50	1	Reducer	57	DD1024226	1	Label, Vent Cap
13	DD1009116	1	Air Muffler				

★ For "oil side" pump element repair kit, order item DC8506221OILSR.

\* For "air side" pump element repair kit, order item DC8506221AIRSR.

**Note:** Item 1 includes a complete pump element assembly, including hydraulic pump and air motor.

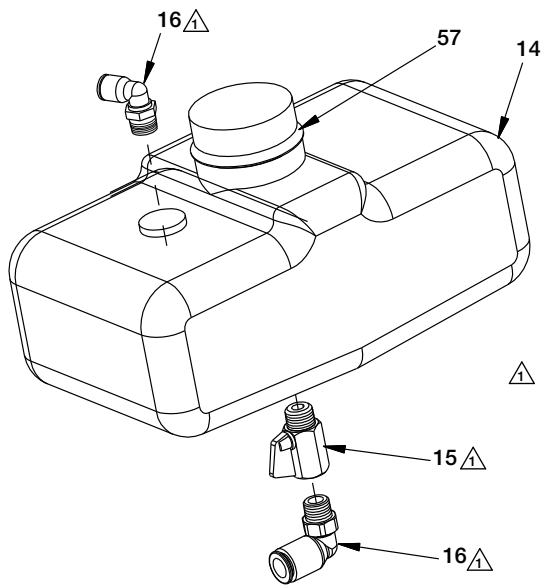

**Note:**

⚠ Torque to hand tight and then 1 to 1-1/2 turns.  
To prevent plastic thread damage, DO NOT OVERTIGHTEN.

**Figure 3, Reservoir Subassembly**

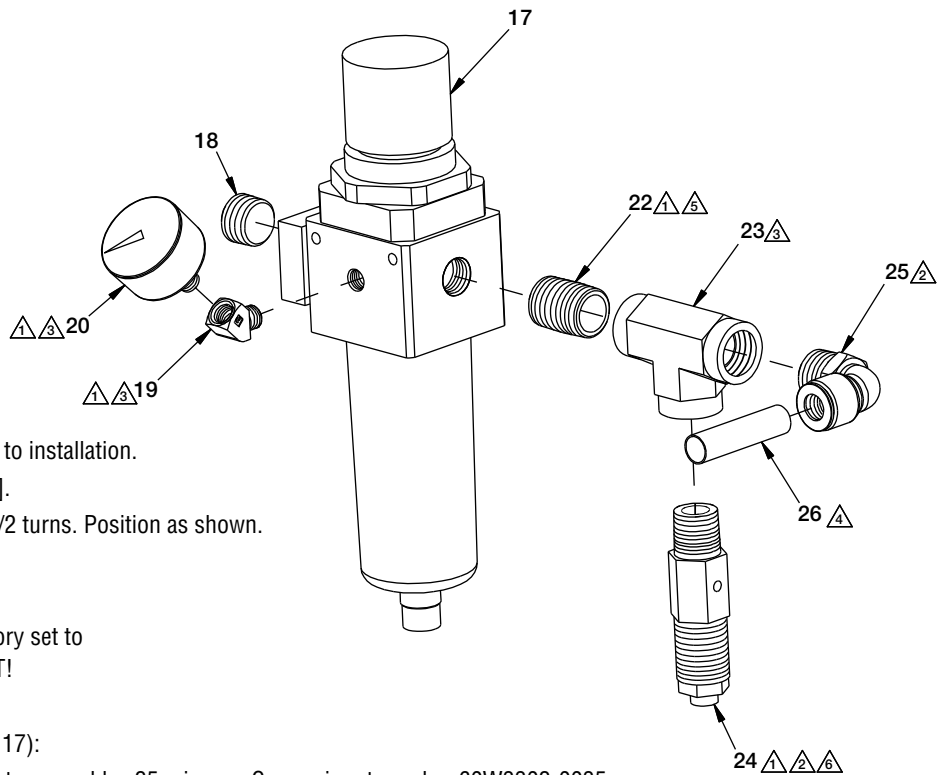

**Notes:**

- ⚠ Apply Loctite 545 to threads prior to installation.
- ⚠ Torque to 20-22 ft-lbs [27-30 Nm].
- ⚠ Torque to hand tight plus 1 to 1-1/2 turns. Position as shown.
- ⚠ Push until bottomed out.
- ⚠ Hand tighten.
- ⚠ **Important:** Safety relief valve factory set to 90 PSI [6,2 bar]. DO NOT ADJUST!

Filter/Regulator information (item 17):

- Bowl filter element and baffle plate assembly, 25 micron - Camozzi part number 60W3302-0035.
- Bowl filter element only, 25 micron - Camozzi part number 70-3302-0034.
- Auto drain bowl assembly - Camozzi part number C238-F11/3.

For ordering information, go to [www.camozzi.com](http://www.camozzi.com).

**Figure 4, Air Line Subassembly**

## Enerpac Worldwide Locations

◆ e-mail: [info@enerpac.com](mailto:info@enerpac.com)

◆ internet: [www.enerpac.com](http://www.enerpac.com)

### Australia and New Zealand

Actuant Australia Ltd.  
P.O. Box 6867  
Wetherhill Park, NSW 1851  
Block V Unit 3  
Regents Park Estate  
391 Park Road  
Regents Park NSW 2143  
Australia  
T +61 287 177 200  
F +61 297 438 648

### Brazil

Power Packer do Brasil Ltda.  
Rua Luiz Lawrie Reid, 548  
09930-760 - Diadema (SP) - Brazil  
T +55 11 5687 2211  
Toll Free: 0800 891 5770

### China (Taicang)

Actuant (China) Industries Co. Ltd.  
No. 6 Nanjing East Road,  
Taicang Economic Dep Zone  
Jiangsu, China  
T +86 0512 5328 7500  
F +86 0512 5335 9690  
Toll Free: +86 400 885 0369

### France, Switzerland, North Africa and French speaking African countries

ENERPAC  
Une division d'Actuant France S.A.S  
Zone Orlytech Bâtiment 516  
1 allée du commandant Mouchotte  
CS 40351  
91550 Paray-Vieille-Poste  
France  
T +33 1 60 13 68 68  
F +33 1 69 20 37 50

### Germany and Austria

Actuant GmbH  
P.O. Box 300113  
D-40401 Düsseldorf  
Willstätterstrasse 13  
D-40549 Düsseldorf, Germany  
T +49 211 471 490  
F +49 211 471 49 28

### India

Actuant India Private Limited  
No. 10, Bellary Road, Sadashivanagar,  
Bangalore, Karnataka 560 080  
India  
T +91 80 3928 9000

### Italy

ENERPAC S.p.A.  
Via Canova 4  
20094 Corsico (Milano)  
T +39 02 4861 111  
F +39 02 4860 1288

### Japan

Enerpac Co., Ltd.  
Besshocho 85-7  
Kita-ku, Saitama-shi 331-0821, Japan  
T +81 48 662 4911  
F +81 48 662 4955

### Middle East, Egypt and Libya

ENERPAC Middle East FZE  
Plot M00737m 1242nd Street  
Jebel Ali Free Zone North  
P.O. Box 18004, Dubai  
United Arab Emirates  
T +971 (0)4 8872686  
F +971 (0)4 8872687

### Russia

Rep. office Enerpac  
Russian Federation  
Admiral Makarova Street 8  
125212 Moscow, Russia  
T +7 495 98090 91  
F +7 495 98090 92

### Norway

Sales Office Norway  
Unit 524, Nydalsveien 28, 0484 Oslo  
P.O. Box 4814, Nydalen 0422 Oslo  
Norway  
T +47 91 578 300

### Southeast Asia, Hong Kong and Taiwan

Actuant Asia Pte Ltd.  
83 Joo Koon Circle  
Singapore 629109  
T +65 68 63 0611  
F +65 64 84 5669  
Toll Free: +1800 363 7722

### South Korea

Actuant Korea Ltd.  
3Ba 717, Shihwa Industrial Complex  
Jungwang-Dong, Shihung-Shi,  
Kyunggi-Do  
Republic of Korea 429-450  
T +82 31 434 4506  
F +82 31 434 4507

### Spain and Portugal

ENERPAC SPAIN, S.L.  
Avda. Valdelaparra N° 27 3ª - L8  
28108 Alcobendas (Madrid), Spain  
T +34 91 884 86 06  
F +34 91 884 86 11

### Sweden, Denmark Finland and Iceland

Enerpac Scandinavia AB  
Kopparlundsvägen 14,  
721 30 Västerås  
Sweden  
T +46 (0) 771 41 50 00

### The Netherlands, Belgium, Luxembourg, Central and Eastern Europe, Baltic States, Greece, Turkey and CIS countries

ENERPAC B.V.  
Galvanistraat 115, 6716 AE Ede  
P.O. Box 8097, 6710 AB Ede  
The Netherlands  
T +31 318 535 911  
F +31 318 535 848

### Enerpac Heavy Lifting Technology B.V.

Spinelstraat 15, 7554 TS Hengelo  
P.O. Box 421, 7550 AK Hengelo  
The Netherlands  
T +31 74 242 20 45  
F +31 74 243 03 38

### South Africa and other English speaking African countries

Enerpac Africa Pty Ltd.  
No. 5 Bauhinia Avenue  
Cambridge Office Park  
Block E  
Highveld Techno Park  
Centurion 0157  
Republic of South Africa  
T: +27 12 940 0656

### United Kingdom and Ireland

ENERPAC UK Ltd.  
5 Coopies Field  
Morpeth, Northumberland  
NE61 6JR, England  
T +44 1670 5010 00

### USA, Latin America and Caribbean

ENERPAC World Headquarters  
P.O. Box 3241  
Milwaukee WI 53201-3241 USA  
N86 W12500 Westbrook Crossing  
Menomonee Falls, Wisconsin 53051  
T +1 262 293 1600  
F +1 262 293 7036  
User inquiries:  
T +1 800 433 2766  
Distributor inquiries/orders:  
T +1 800 558 0530  
F +1 800 628 0490

All Enerpac products are  
guaranteed against defects  
in workmanship and materials  
for as long as you own them.

For the location of your nearest  
authorized Enerpac Service Center,  
visit us at [www.enerpac.com](http://www.enerpac.com)