

Document Number	Document Revision	Document Revision Date	Product Date Code Beginning With
L4087	D	04/2017	A

**NOTICE:**

Enerpac recommends that all parts included in a service assembly or repair kit be installed to ensure optimum performance of the repaired product.

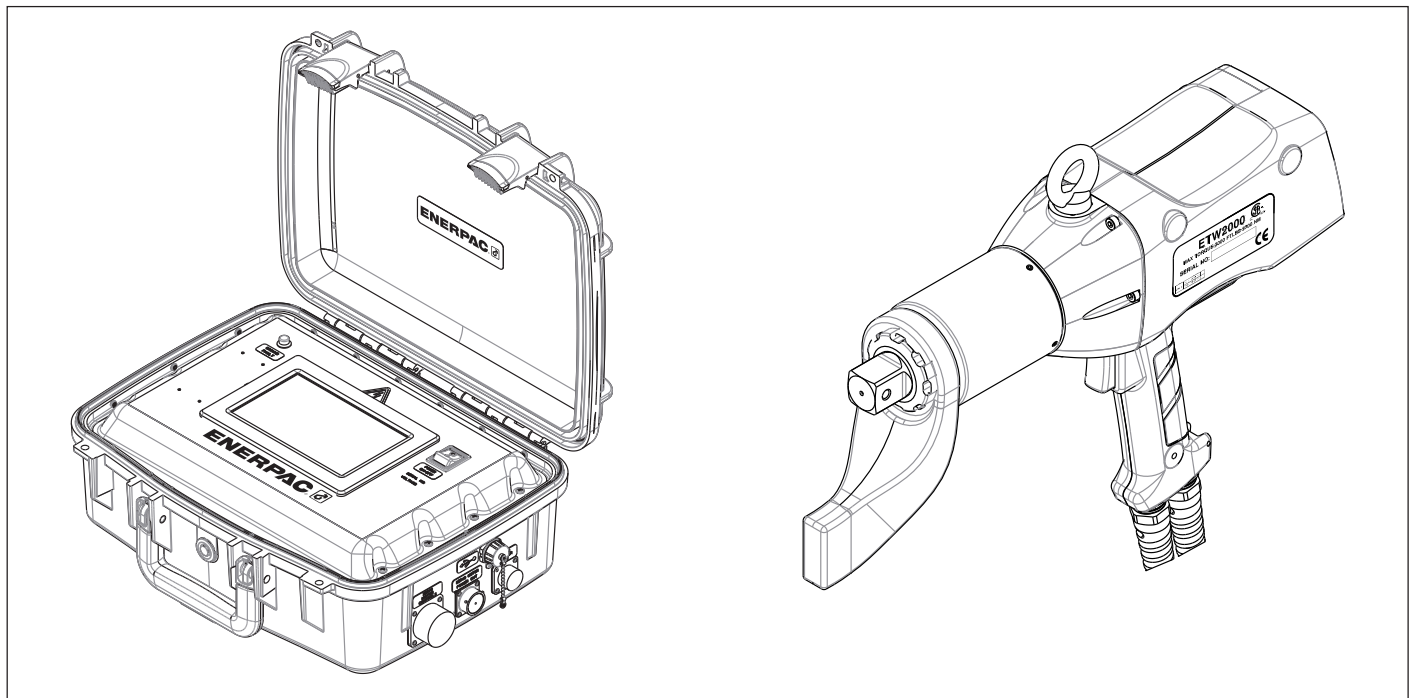
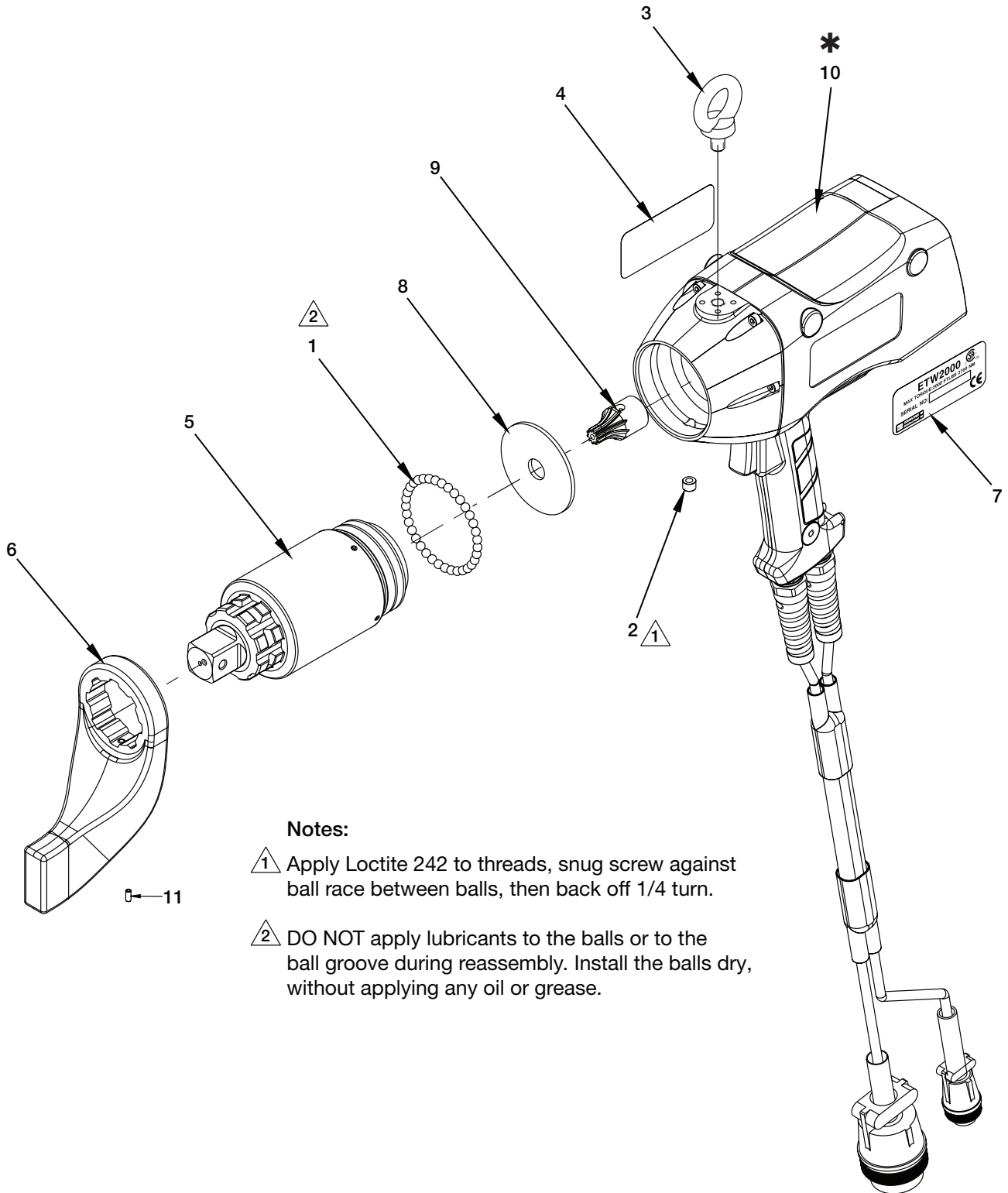

**Table of Contents:**

	Page		Page
Fig. 1, Main Assembly . . . . .	2	Fig. 7A, Control Box Ass'y - Touchscreen Panel . . . . .	12
Fig. 2, Electric Motor and Keypad Display . . . . .	4	Fig. 7B, Control Box Assembly - Case, Cover and Side-Mounted Connections . . . . .	14
Fig. 3, Gear Box Assembly . . . . .	6	Fig. 7C, Control Box Major Components, 115V . . . . .	16
Fig. 4A, Accessories . . . . .	8	Fig. 7D, Control Box Major Components, 230V . . . . .	18
Fig. 4B, Extended Drive Components . . . . .	9	Fig. 7E, Additional Control Box Components . . . . .	20
Fig. 5, Wrench Protective Storage Case . . . . .	10	Fig. 7F, Additional Control Box Components . . . . .	21
Fig. 6, Control Box and Power Cords . . . . .	11		

**⚠ WARNING** Before beginning any maintenance, repair, adjustment or inspection procedures, disconnect electrical control box cord from AC power supply. Disconnect wrench electrical cables from control box. Failure to observe these precautions could result in death or serious personal injury.

**Fig. 1, Main Assembly**



**Notes:**

- 1 Apply Loctite 242 to threads, snug screw against ball race between balls, then back off 1/4 turn.
- 2 DO NOT apply lubricants to the balls or to the ball groove during reassembly. Install the balls dry, without applying any oil or grease.

**\* NOTICE:** Recalibration of wrench and control box is required if electric motor (Fig 2, item #17) is replaced. Firmware version of control box must match firmware version of wrench. See Enerpac Authorized Service Center for additional information.

**Repair Parts List, Fig. 1**

**L4087**

Item	Part Number	Qty.	Description
1	☆ B1007016	35	Ball, 1/4" diameter
2	☆ BF3804027A	1	Set Screw
3	CAA1100028-4C	1	Eyebolt
4	+ DD4517026	4	Decal, Brand ETW
5	◆ (See Fig. 3)	1	Assembly, Gear Box
6	*◆ DD5340900SR	1	Reaction Arm (standard)
7	DD5353026	1	Decal, ETW2000, Serial No.
8	☆ DD5356108	1	Washer, Delrin, ETW
9	DD5357229	1	Pinion, Input, ETW
10	+ (See Fig. 2)	1	Assembly, Motor and Housing,
11	*◆ DD5448600SR	1	Set Screw, Reaction Arm

**Notes:**

- ◆ Item included in service assembly TW2000RSR, Gear Box Assembly with Reaction Arm.
- \* Item included in service assembly RATWS, Standard Reaction Arm.
- ☆ Item included in service assembly DD5356108SR, Swivel Hardware Kit.
- + Item included in service assembly DD5388900SR, Electric Motor Service Assembly.

**NOTICE:** Except as indicated, items included in service assemblies are not sold separately.

**Fig. 2, Electric Motor and Keypad Display**

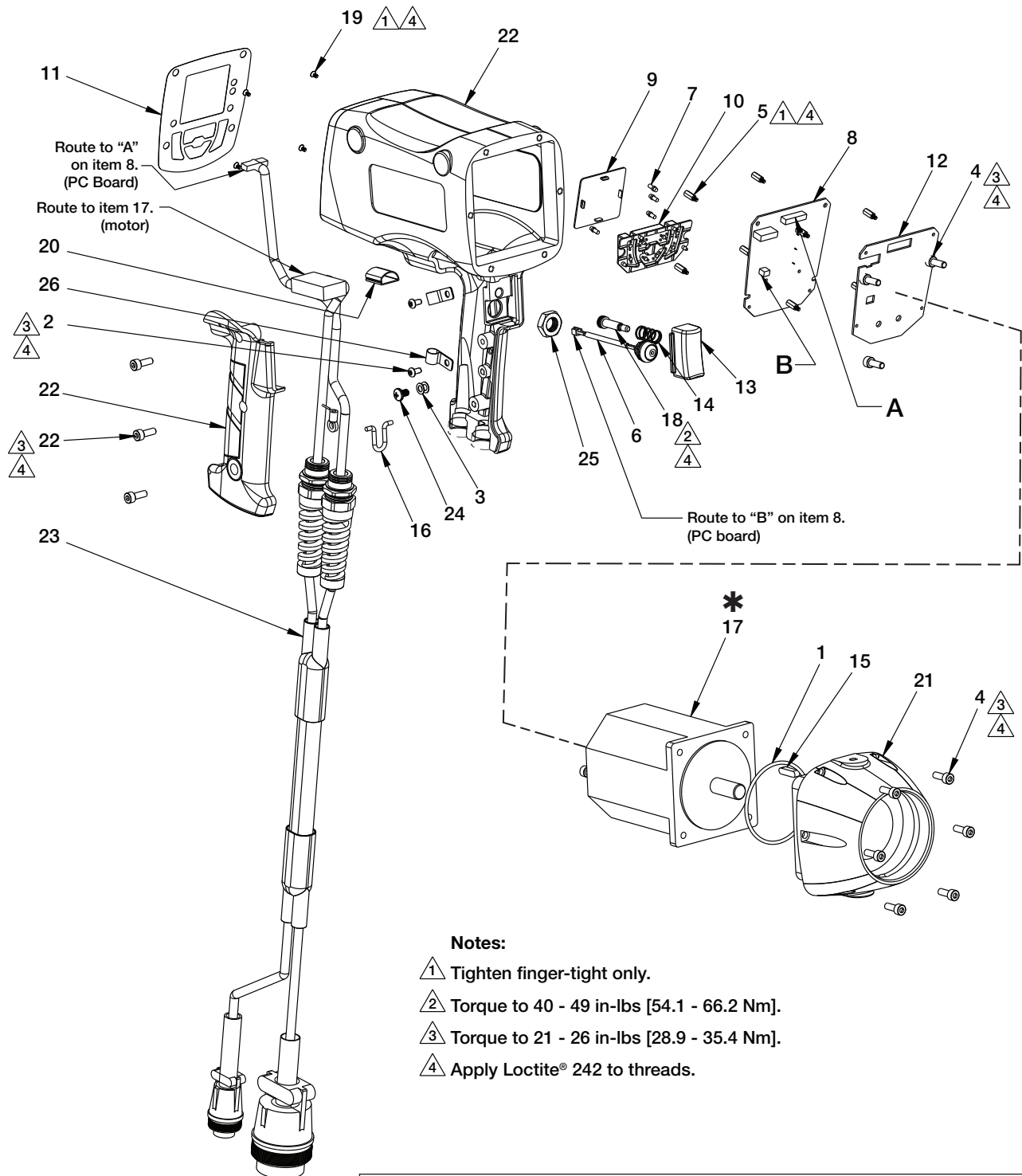

**Notes:**

- ① Tighten finger-tight only.
- ② Torque to 40 - 49 in-lbs [54.1 - 66.2 Nm].
- ③ Torque to 21 - 26 in-lbs [28.9 - 35.4 Nm].
- ④ Apply Loctite® 242 to threads.

**\* NOTICE:** Recalibration of wrench and control box is required if electric motor (item #17) is replaced. Firmware version of control box must match firmware version of wrench. See Enerpac Authorized Service Center for additional information.

**Repair Parts List, Fig. 2**

**L4087**

Item	Part Number	Qty.	Description
1	Ⓢ B1279503	1	O-Ring (service only)
2	Ⓢ CBE413028-1E	2	Screw, BHCS, M4 x 8MM LG GR 10.9 Zinc
3	CCE1050108-6A	2	Lock Washer (Bulkhead)
4	Ⓢ DD3659028	14	Screw, SHC, M5 x 0.8 x 14 Stainless Steel
5	Ⓢ Ⓢ Ⓢ DD3752111	9	Standoff
6	▲ Ⓢ DD3793960	1	Switch Wires
7	Ⓢ DD3969186	4	Light Pipe (display)
8	* Ⓢ DD3970827	1	Printed Circuit Board w/display (Firmware Version 1.2)
9	Ⓢ DD3971354	1	Lens (display)
10	DD3972375	1	Keypad (display)
11	Ⓢ DD3973026	1	Label (display)
12	Ⓢ DD3974689	1	Shield (display)
13	Ⓢ DD3977144	1	Trigger
14	Ⓢ DD3979110	1	Spring, Trigger
15	Ⓢ DD3980251	1	Square Key, 5mm x 20mm, Rounded Ends
16	Ⓢ DD3982117	1	Hanger
17	DD3985259	1	Motor, Electric
18	Ⓢ DD4109028	1	Screw, Shoulder, .25 Dia x .75 L, 10-24
19	Ⓢ Ⓢ Ⓢ DD4519028	5	Screw, Flat Head Cap, M2.50 x .45 x 5
20	Ⓢ DD5119017	1	Cable Holder, 1/2"
21	DD5165101	1	Adapter Plate
22	DD5351900	1	Housing
23	DD5421960	1	Cable, Servo Power and Control
24	Ⓢ DD5679028	3	Screw, M5 x 8 Philips Pan Hd
25	Ⓢ DD5680028	1	Nut, M12 x 1.75
26	Ⓢ F100299-27	3	Clamp, Cable

**Notes:**

- Ⓢ Item included in DD5963900 PCB Repair Kit ETW.
- Ⓢ Item included in DD5964900 Trigger Repair Kit ETW.
- Ⓢ Item included in DD5965900 Hardware Repair Kit ETW - Handle Assembly.
- Ⓢ Item included in DD5967900 Intermediate PCB Repair Kit ETW.
- ▲ Item included in a repair kit but may also be ordered separately.
- \* Firmware version of wrench printed circuit board must match firmware version of control box. Contact Enerpac Authorized Service Center for additional information.

**NOTICE:** Except as indicated, items included in repair kits are not sold separately.

**Fig. 3, Gear Box Assembly**

**NOTICE:** Recalibration of wrench and control box is required if any gear box components are replaced. See Enerpac Authorized Service Center for additional information.

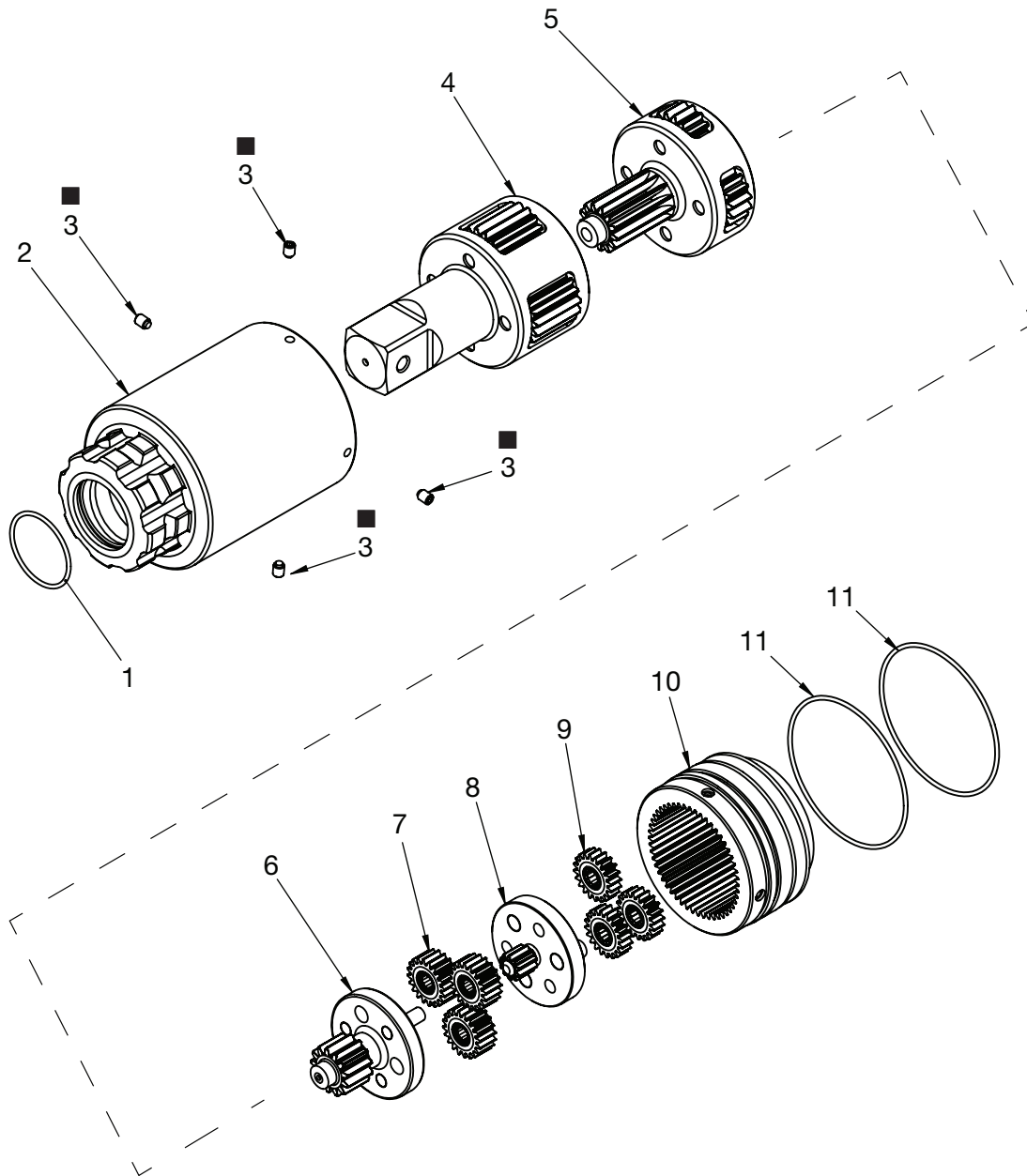

**NOTICE:** During reassembly, be sure that all gear teeth and bearing interfaces are coated with Moly grease. See Fig. 3 parts list, item 12.

■ **ITEM 3:** Apply Loctite 242 to setscrew threads. Install setscrew and tighten it until snug. Then, back-off setscrew 1/4 turn.

**Repair Parts List, Fig. 3**

**L4087**

Item	Part Number	Qty.	Description
1	❖ ★ ◆ Not sold separately	1	O-Ring, Small
2	▲ ★ ◆ DD5450600SR	1	Gear Housing, TW2000
3	❖ ★ ◆ (not sold separately)	4	Set Screw
4	▲ ★ ◆ DD5451600SR	1	Assembly, Drive Stage, TW2000
5	▲ ★ ◆ DD5457600SR	1	Gear Carrier, Third Stage, TW2000
6	▲ ★ ◆ DD5455600SR	1	Gear Carrier, Second Stage, TW2000
7	▲ ❖ ★ ◆ DD5456600SR	1	Planetary Gears, Second Stage, TW2000
8	▲ ★ ◆ DD5453600SR	1	Gear Carrier, First Stage, TW2000
9	▲ ❖ ★ ◆ DD5454600SR	1	Planetary Gears, First Stage, TW2000
10	▲ ★ ◆ DD5452600SR	1	Ring Gear, TW2000
11	❖ ★ ◆ (not sold separately)	2	O-Ring, Large
12	⚙ DD5587600SR	A/R	Grease, Moly, 16 oz, 454 g (not shown)

**Notes:**

- ❖ Item included in MKTW2000K Maintenance Kit.
- ★ Item included in service assembly TW2000SR, Replacement Gear Box Assembly.
- ◆ Item included in service assembly TW2000RSR, Replacement Gear Box Assembly with Reaction Arm.  
(See Figure 1 for reaction arm and set screw)
- ❖ Item includes set of three planetary gears with bearings.
- ⚙ During reassembly, be sure that all gear teeth and bearing interfaces are coated with Molybdenum Disulfide grease.
- ▲ Item included in a service assembly, but may also be ordered separately.

A/R = Order as required.

**NOTICE:** Except as indicated, items included in repair kits and service assemblies are not sold separately.

**Fig. 4A, Accessories**

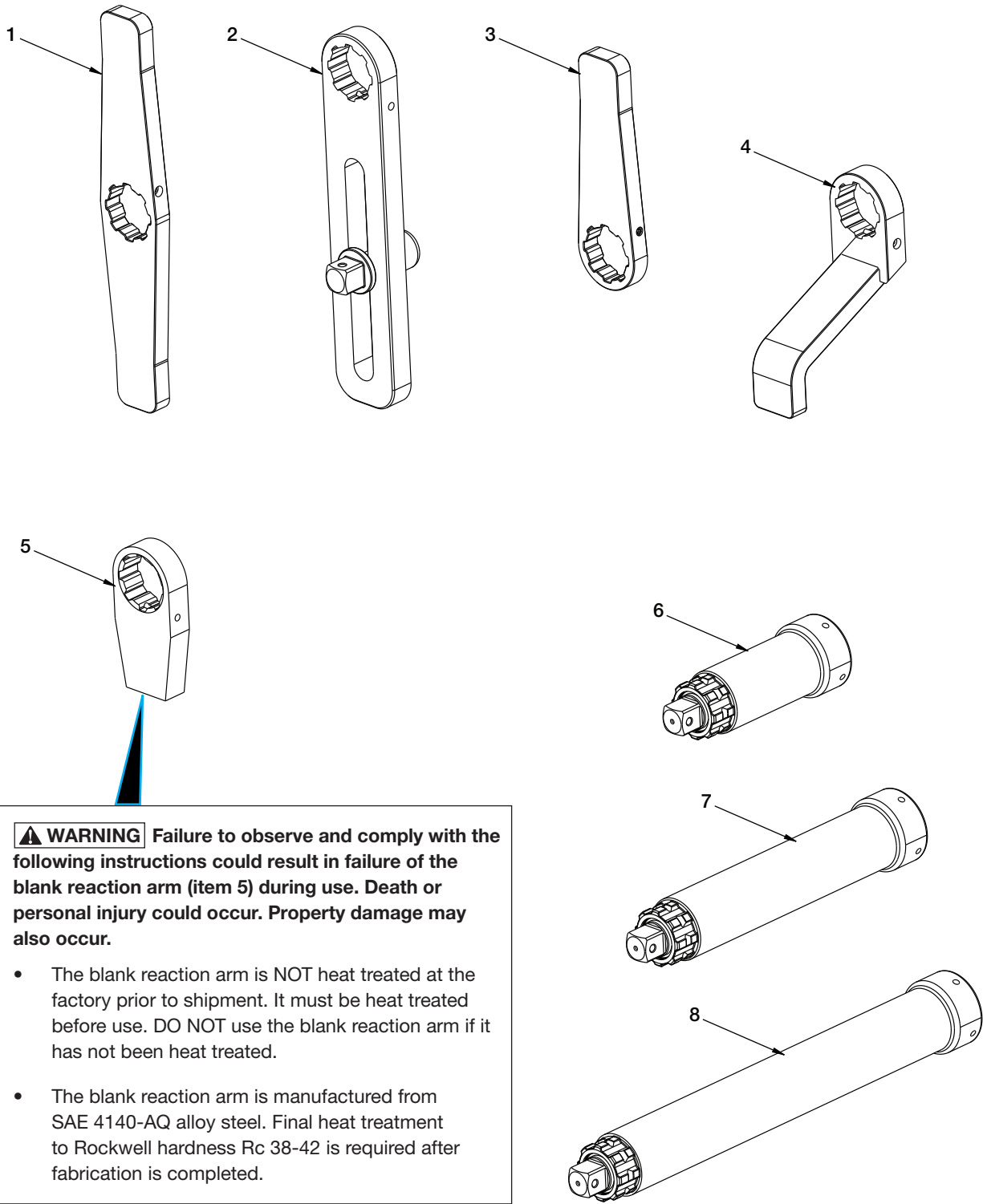

**⚠ WARNING** Failure to observe and comply with the following instructions could result in failure of the blank reaction arm (item 5) during use. Death or personal injury could occur. Property damage may also occur.

- The blank reaction arm is NOT heat treated at the factory prior to shipment. It must be heat treated before use. DO NOT use the blank reaction arm if it has not been heat treated.
- The blank reaction arm is manufactured from SAE 4140-AQ alloy steel. Final heat treatment to Rockwell hardness Rc 38-42 is required after fabrication is completed.



Repair Parts List, Fig. 4A				L4087
Item	Part Number	Qty.	Description	
1	DSATWS	1	Reaction Arm, Straight, Double	
		1	Screw, 1/4 - 28 x 2" long	
		1	Nylon Hex Nut, 1/4 - 28	
2	SLRATWS	1	Reaction Arm, Sliding	
		1	Screw, 1/4 - 28 x 2 - 1/4" long	
		1	Nylon Hex Nut, 1/4 - 28	
3	SRATWS	1	Reaction Arm, Straight	
		1	Screw, 1/4 - 28 x 2" long	
		1	Nylon Hex Nut, 1/4 - 28	
4	ERATWS	1	Reaction Arm, Extended	
		1	Screw, 1/4 - 28 x 2" long	
		1	Nylon Hex Nut, 1/4 - 28	
5	BLTWS	1	Reaction Arm, Blank	
		1	Screw, 1/4 - 28 x 2" long	
		1	Nylon Hex Nut, 1/4 - 28	
6	ED6TWS	1	Extended Drive, 6" long	
		1	Screw, 1/4 - 28 x 3/8" long	
7	ED12TWS	1	Extended Drive, 12" long	
		1	Screw, 1/4 - 28 x 3/8" long	
8	ED18TWS	1	Extended Drive, 18" long	
		1	Screw, 1/4 - 28 x 3/8" long	

**NOTICE:** Mounting hardware not shown. See Figure 1 for standard reaction arm.

Fig. 4B, Extended Drive Components

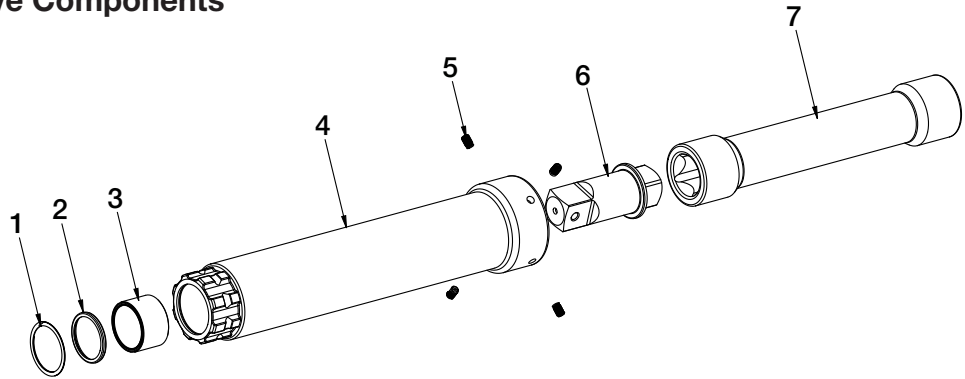

Repair Parts List, Fig. 4B				L4087	
Item	Drive Model / Part Number			Qty.	Description
	ED6TWS	ED12TWS	ED18TWS		
1	DD6632249SR	DD6632249SR	DD6632249SR	1	Snap Ring
2	DD6633503SR	DD6633503SR	DD6633503SR	1	O-Ring
3	DD6636039SR	DD6636039SR	DD6636039SR	1	Bushing
4	DD6621001SR	DD6622001SR	DD6623001SR	1	Housing
5	DD6638027SR	DD6638027SR	DD6638027SR	1	Set Screw (package of four)
6	DD6560229SR	DD6560229SR	DD6560229SR	1	Square Drive
7	DD6626104SR	DD6627104SR	DD6628104SR	1	Drive Extension

**Fig. 5, Wrench Protective Storage Case**

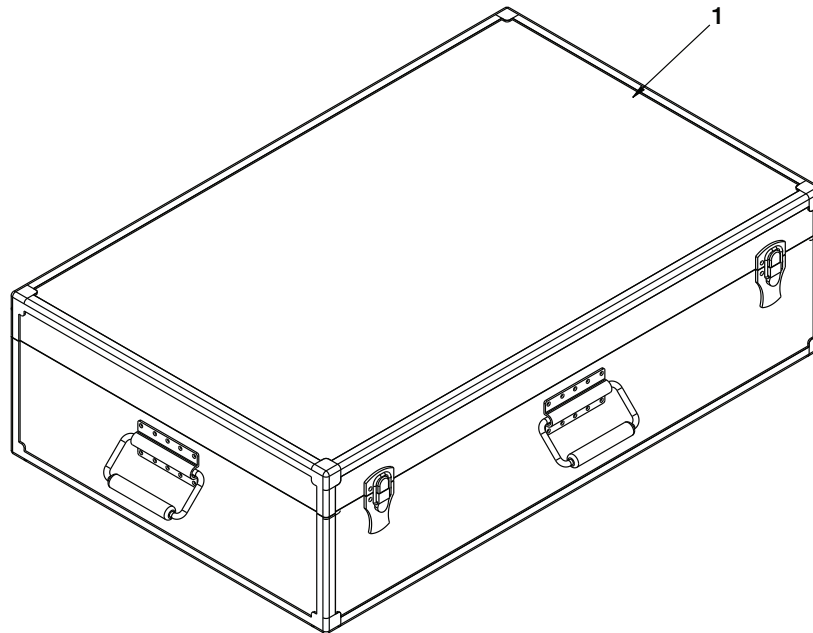

Repair Parts List, Fig. 5			L4087
Item	Part Number	Qty.	Description
1	DD4727530	1	Protective Storage Case

**Fig. 6, Control Box and Power Cords**

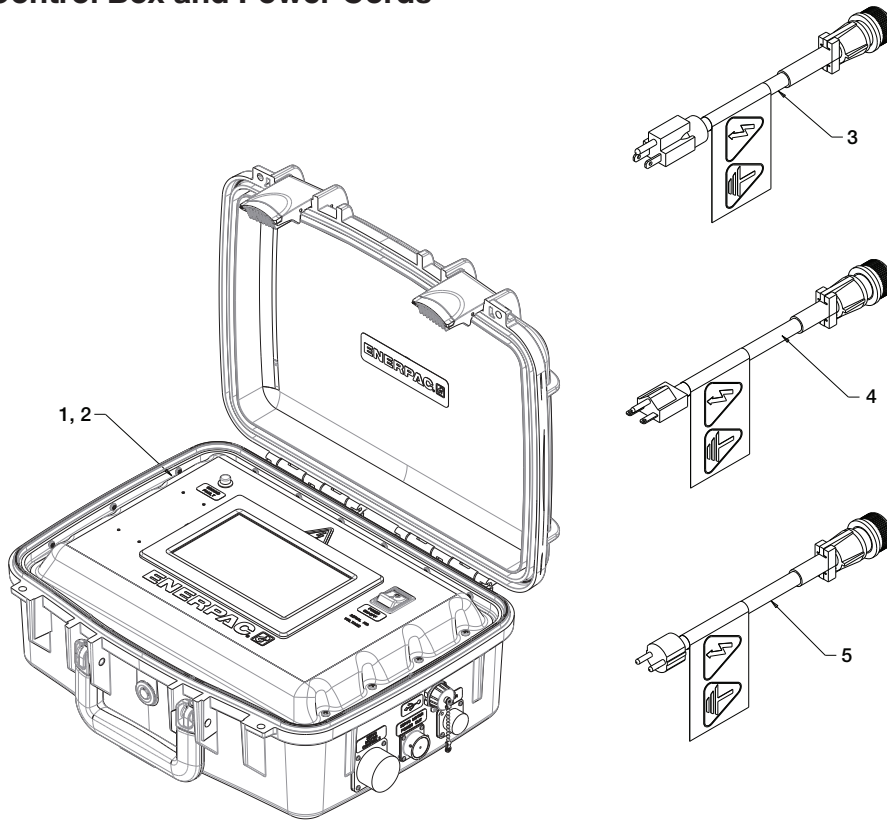

Repair Parts List, Fig. 6 (115V Control Box)				L4087
Item	Part Number	Qty.	Description	
1	DD5349900	1	Control Box, Electrical, 115 volt	
3	DD3718960	1	Power Cord, 115V, 60Hz (for use only with item 1)	



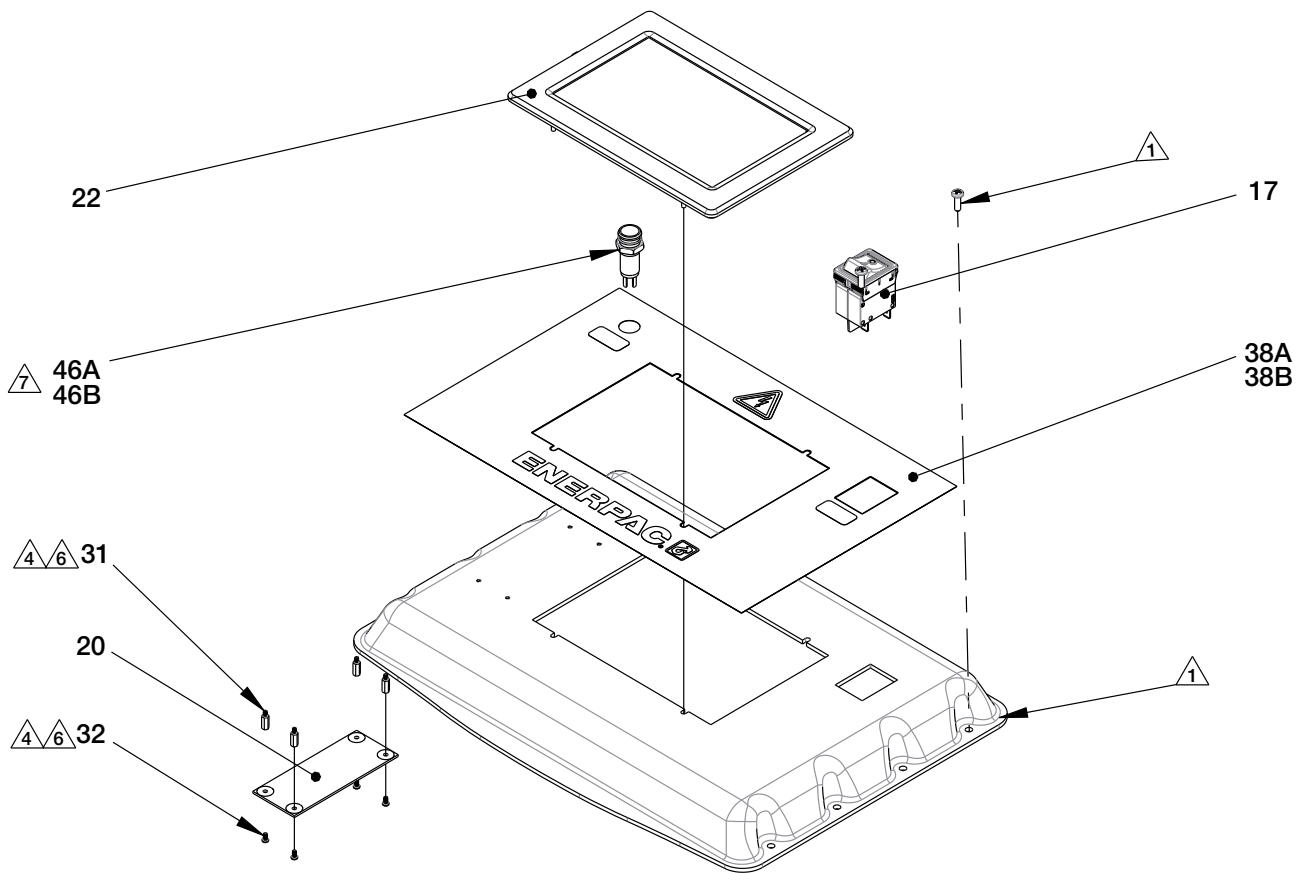

Repair Parts List, Fig. 6 (230V Control Box)				L4087
Item	Part Number	Qty.	Description	
2	DD5350900	1	Control Box, Electrical, 230 volt	
4	DD3719960	1	Power Cord, 230V, 50Hz (for use only with item 2)	
5	DD3720960	1	Power Cord, 230V, 60Hz (for use only with item 2)	

**NOTICE:** Control box AND wrench must be recalibrated when a new control box is ordered. Firmware version of control box must match firmware version of wrench. See Enerpac Authorized Service Center for additional information.

**Fig. 7A, Control Box Assembly - Touchscreen Panel**



**Notes:**

-  Item included with control box case. See Figure 7B for additional information.
-  Tighten item 31 finger tight.
-  Apply Loctite® 242 to threads.
-  Apply heat shrink tubing over electrical connections.

**NOTICE:**

*Recalibration of wrench and control box is required:*

- *When the electric motor is replaced.*
- *When any gear box components are replaced.*
- *When the control box is replaced.*

*Firmware version of control box must match firmware version of wrench.*

*See Enerpac Authorized Service Center for additional information.*

**Repair Parts List, Fig. 7A**

**L4087**

Item	Part Number	Qty.		Description
		115V Models	230V Models	
17	DD3717372	1	1	Switch, Main Power
20	▲ ⑤ DD3725827	1	1	Printed Circuit Board (Intermediate)
22	*▲ ⑥ DD3731380	1	1	Touchscreen Panel, Computer (includes microSD memory card - see Fig. 7F, item #66)
31	⑤ DD3752111	4	4	Standoff
32	⑤ DD3753028	4	4	Screw, BHSC, M2.5 x .45 x 5
38A	DD5985026	1	-	Decal, Control Box Panel, 115V
38B	DD5398026	-	1	Decal, Control Box Panel, 230V
46A	DD6017380	1	-	LED, Dual Color
46B	DD5984380	-	1	LED, Dual Color

**Notes:**

⑤ Item included in DD5967900 Intermediate PCB Repair Kit ETW.

⑥ Item included in DD5968900 Touchscreen Repair Kit ETW.

▲ Item included in a service assembly, but may also be ordered separately.

\* Firmware version of control box must match firmware version of wrench. Always check wrench firmware version whenever replacing the touchscreen panel or the microSD memory card. Contact Enerpac Authorized Service Center for additional information.

**NOTICE:** Except as indicated, items included in repair kits and service assemblies are not sold separately.

**Fig. 7B, Control Box Assembly - Case, Cover and Side-Mounted Connections**

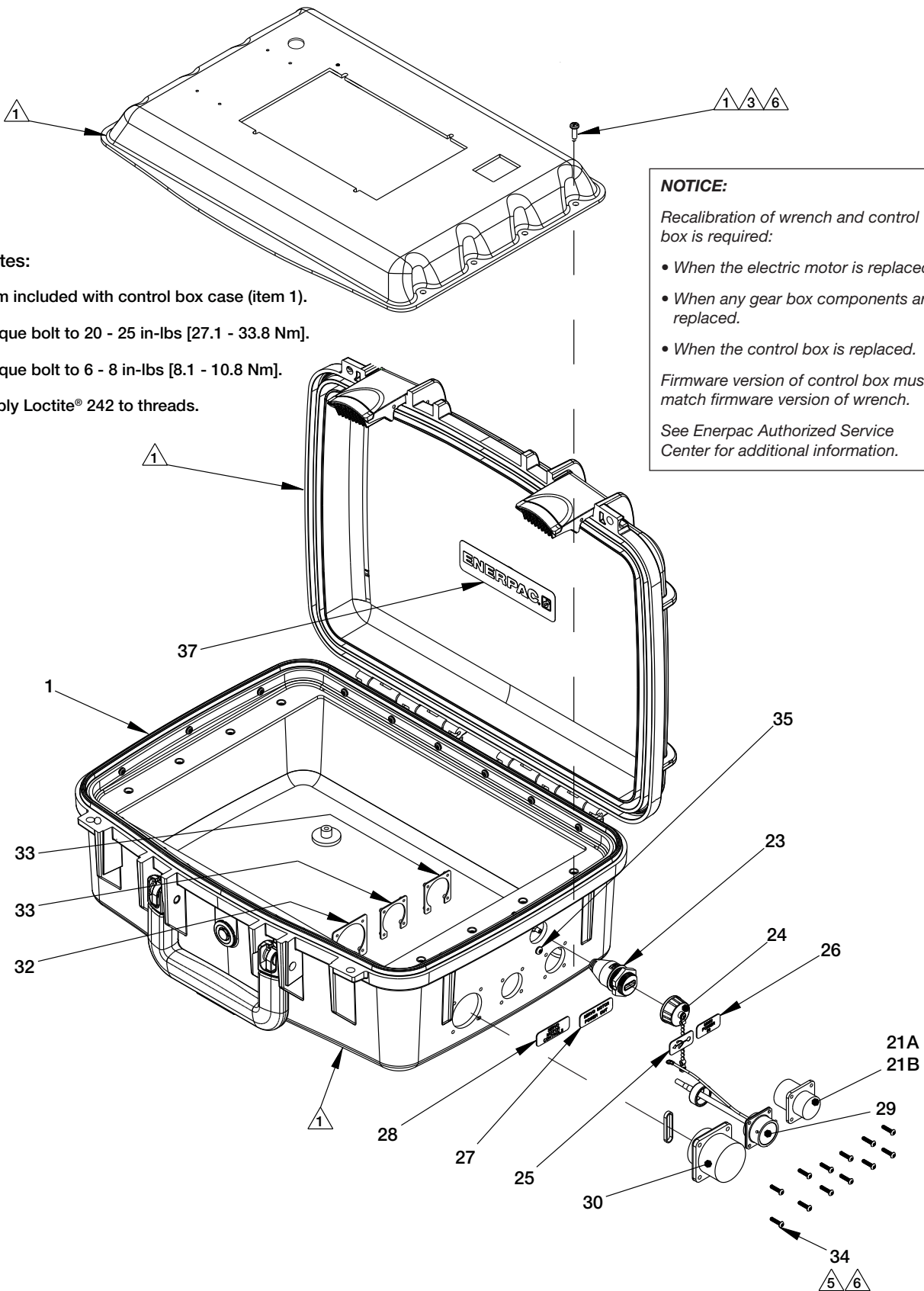

**Notes:**

- 1 Item included with control box case (item 1).
- 3 Torque bolt to 20 - 25 in-lbs [27.1 - 33.8 Nm].
- 5 Torque bolt to 6 - 8 in-lbs [8.1 - 10.8 Nm].
- 6 Apply Loctite® 242 to threads.

**NOTICE:**

Recalibration of wrench and control box is required:

- When the electric motor is replaced.
- When any gear box components are replaced.
- When the control box is replaced.

Firmware version of control box must match firmware version of wrench.

See Enerpac Authorized Service Center for additional information.

**Repair Parts List, Fig. 7B**

**L4087**

Item	Part Number	Qty.		Description
		115V Models	230V Models	
1	DD5274530	1	1	Case, Control Box (includes lid and top panel)
21A	⑦ DD3726960	1	-	Connector and Cable Assy., 115V Power In
21B	⑪ DD3801960	-	1	Connector and Cable Assy., 230V Power In
23	⑧ DD3733380	1	1	USB Socket and Cable Assembly
24	⑧ DD3734380	1	1	Cover, USB Port (with ball chain)
25	⑧ DD3738026	1	1	Decal, Data Output
26	⑪ ⑦ DD3739026	1	1	Decal, Main Power In
27	⑥ DD3740026	1	1	Decal, Servo Motor Power Out
28	⑤ DD3741026	1	1	Decal, Servo Motor Controls
29	⑥ DD3746960	1	1	Connector and Cable Assy., Servo Motor Power Out
30	⑤ DD3747960	1	1	Connector and Cable Assy., Servo Motor Controls
32	⑤ DD6254021	1	1	Nut Plate, #4-40, Servo Motor Controls
33	⑪ ⑦ ⑥ DD6255021	2	2	Nut Plate, #4-40, Servo Motor Power Out & Control Box Power In
34	⑪ ⑦ ⑥ ⑤ DD6252028	12	12	Screw, BHCS, #4-40 x 1/2
35	⑧ DD3758028	1	1	Screw, Thread Forming #6-19
37	DD4971026	2	2	Decal, Control Box, Enerpac

**Notes:**

- ⑤ Item included in DD5977900 Data Cable Connector Repair Kit ETW.
- ⑥ Item included in DD5978900 Power Cable Connector Repair Kit ETW.
- ⑦ Item included in DD5979900 Mains Power Connector Repair Kit 115V ETW.
- ⑧ Item included in DD5980900 USB Cable Repair Kit ETW.
- ⑪ Item included in DD6055900 Mains Power Connector Repair Kit 230V ETW.

**NOTICE:** Except as indicated, items included in repair kits and service assemblies are not sold separately.

**Fig. 7C, Control Box Major Components, 115V Models**

**NOTICE:**

Recalibration of wrench and control box is required:

- When the electric motor is replaced.
- When any gear box components are replaced.
- When the control box is replaced.

Firmware version of control box must match firmware version of wrench.

See Enerpac Authorized Service Center for additional information.

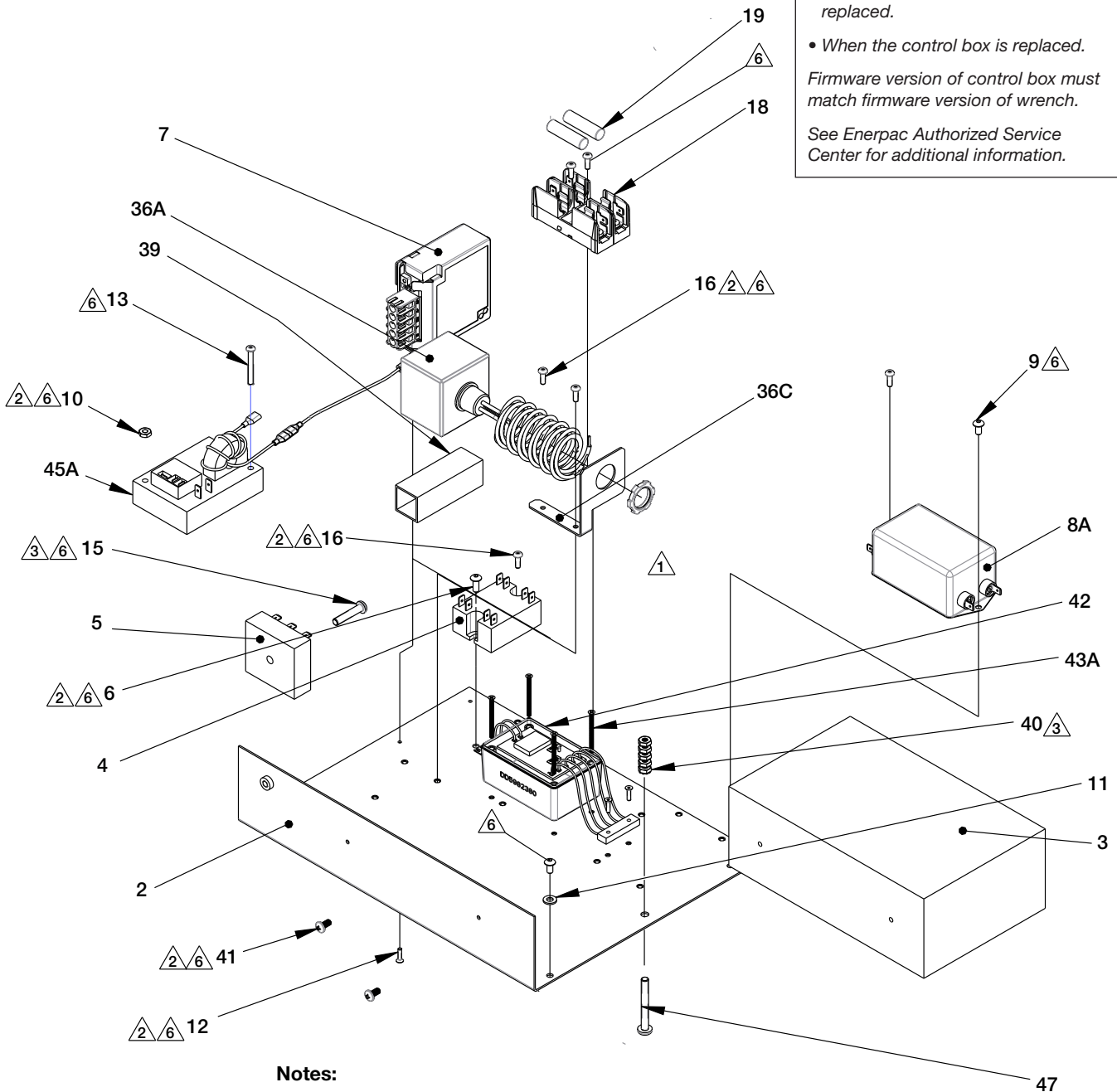

**Notes:**

- △1 See Figures 7E and 7F for additional components.
- △2 Torque bolt to 10 - 12 in-lbs [13.5 - 16.2 Nm].
- △3 Torque bolt to 20 - 25 in-lbs [27.1 - 33.8 Nm].
- △5 Torque bolt to 6 - 8 in-lbs [8.1 - 10.8 Nm].
- △6 Apply Loctite® 242 to threads of all threaded fasteners.

**115V  
MODELS**



**Repair Parts List, Fig. 7C**

**L4087**

<b>Item</b>	<b>Part Number</b>	<b>Qty.</b>	<b>Description</b>
2	DD5275101	1	Subplate
3	▲ ⑨ DD3724380	1	Servo Drive
4	▲ ① DD5285380	1	Relay, Solid State Dual Pole
5	▲ ⑧ DD5286380	1	Timer, 24V
6	① BF1906728	1	Screw, #10-32 x .38
7	▲ ⑦ DD3730380	1	Power Supply, 24 Volt DC
8A	▲ ② DD3781380	1	EMI Filter, 20 Amps (for 115V)
9	② BF1904728	2	Screw, #10-32 x .25
10	⑩ B1018121	1	Nut, Hex #10-32
11	B1085108X	1	Washer, Flat, #10, Zinc Plated
12	⑦ CBA317028-1B	4	Screw, Hex, Socket, CSK Head M3 x 12
13	⑩ CBA427028-1E	1	Capscrew, Button Hd M4.0 x 0.7 x 35.0
15	⑧ CBA625028-1E	1	Capscrew, Button Hd M6 x 30mm
16	⑨ ④ ② ① CCA417028-1E	6	Capscrew, Button Hd M4 x M7 x12
18	④ DD3721378	1	Fuse Block, 2 Pole
19	▲ ④ DD3722378	2	Fuse, 10 Amp
36A	▲ ⑨ DD3768380	1	Surge Suppressor, 115V
36C	⑨ DD3769380	1	Bracket, Mounting
39	DD5407380	1	Wire Duct, 3.00 inch
41	⑨ DD5682028	2	Screw, BHSC, 10-32 x .375
40	DD5681028	5	Lock Nut, M6 with Tooth Washer
42	DD6104900	1	Voltage Monitor Module (includes item 43A)
43A	DD5983028	4	Screw, Flat Head Philips, M3 x 40L
45A	⑩ DD6015900	1	Ground Fault Sensor, 115V
47	DD6026028	1	Screw, Pan Head, Philips, M6 x 50L

**Notes:**

- ① Item included in DD5973900 SSR Repair Kit ETW.
- ② Item included in DD5974900 EMI Filter Repair Kit 115V ETW.
- ④ Item included in DD5976900 Fuse Block Repair Kit ETW.
- ⑦ Item included in DD5969900 Power Supply Repair Kit ETW.
- ⑧ Item included in DD5970900 Timer Repair Kit ETW.
- ⑨ Item included in DD5981900 Servo Drive Repair Kit ETW.
- ⑨ Item included in DD5971900 Surge Suppressor Repair Kit 115V ETW.
- ⑩ Item included in DD6516900 Ground Fault Sensor Repair Kit 115V ETW.
- ▲ Item included in a repair kit or service assembly, but may also be ordered separately.

**NOTICE:** Except as indicated, items included in repair kits are not sold separately.

**Fig. 7D, Control Box Major Components, 230V Models**

**NOTICE:**  
 Recalibration of wrench and control box is required:

- When the electric motor is replaced.
- When any gear box components are replaced.
- When the control box is replaced.

Firmware version of control box must match firmware version of wrench.  
 See Enerpac Authorized Service Center for additional information.

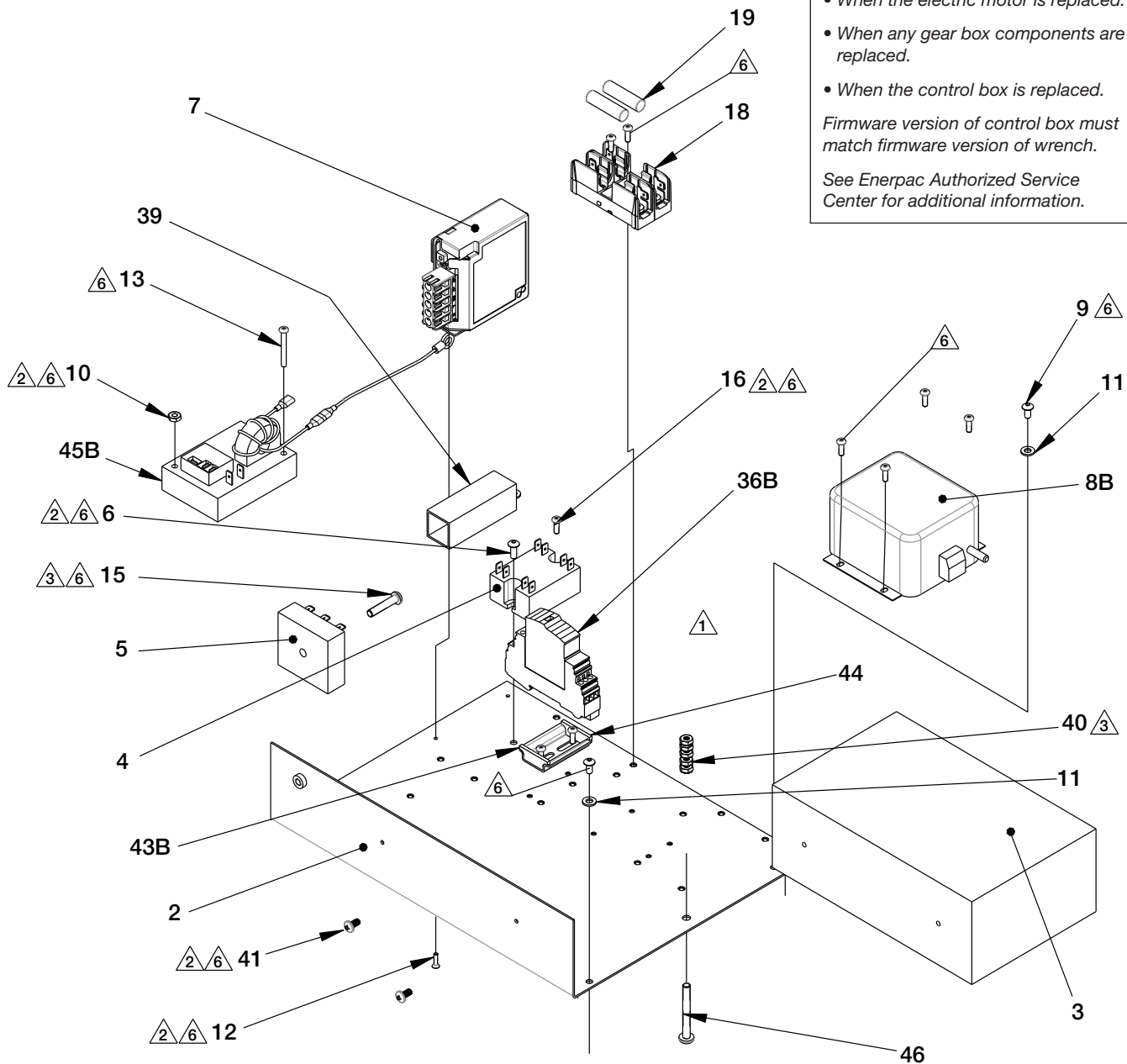

**Notes:**

- ① See Figures 7E and 7F for additional components.
- ② Torque bolt to 10 - 12 in-lbs [13.5 - 16.2 Nm].
- ③ Torque bolt to 20 - 25 in-lbs [27.1 - 33.8 Nm].
- ⑤ Torque bolt to 6 - 8 in-lbs [8.1 - 10.8 Nm].
- ⑥ Apply Loctite® 242 to threads of all threaded fasteners.

**230V  
 MODELS**

**Repair Parts List, Fig. 7D**

**L4087**

<b>Item</b>	<b>Part Number</b>	<b>Qty.</b>	<b>Description</b>
2	DD5275101	1	Subplate
3	▲ ⑨ DD3724380	1	Servo Drive
4	▲ ① DD5285380	1	Relay, Solid State Dual Pole
5	▲ ⑧ DD5286380	1	Timer, 24V
6	① BF1906728	1	Screw, #10-32 x .38
7	▲ ⑦ DD3730380	1	Power Supply, 24 Volt DC
8B	▲ ③ DD3723380	1	EMI Filter, 12 Amps (for 230V)
9	BF1904728	2	Screw, 10-32 x .25
10	⑩ B1018121	1	Nut, Hex #10-32
11	B1085108X	2	Washer, Flat, #10, Zinc Plated
12	⑦ CBA317028-1B	4	Screw, Hex, Socket, CSK Head M3 x 12
13	⑩ CBA427028-1E	1	Capscrew, Button Hd M4.0 x 0.7 x 35.0
15	⑧ CBA625028-1E	1	Capscrew, Button Hd M6 x 30mm
16	⑩ ④ ③ ① CCA417028-1E	9	Capscrew, Button Hd M4 x M7 x12
18	④ DD3721378	1	Fuse Block, 2 Pole
19	▲ ④ DD3722378	2	Fuse, 10 Amp
36B	⑩ DD3718372	1	Surge Suppressor, 230V
39	DD5407380	1	Wire Duct, 3.00 inch
40	DD5681028	5	Lock Nut, M6 with Tooth Washer
41	⑨ DD5682028	2	Screw, BHSC, 10-32 x .375
43B	⑩ DD6007111	1	DIN Rail, 35 x 7.5 x 50L
44	⑩ DD6008111	1	End Cap, DIN Rail
45B	⑩ DD6014960	1	Ground Fault Sensor, 230V
46	DD6026028	1	Screw, Pan Head, Philips, M6 x 50L

**Notes:**

- ① Item included in DD5973900 SSR Repair Kit ETW.
- ③ Item included in DD5975900 EMI Filter Repair Kit 230V ETW.
- ④ Item included in DD5976900 Fuse Block Repair Kit ETW.
- ⑦ Item included in DD5969900 Power Supply Repair Kit ETW.
- ⑧ Item included in DD5970900 Timer Repair Kit ETW.
- ⑨ Item included in DD5981900 Servo Drive Repair Kit ETW.
- ⑩ Item included in DD5972900 Ground Fault Sensor Repair Kit ETW.
- ⑩ Item included in DD6054900 Surge Suppressor Repair Kit 230V ETW.
- ▲ Item included in a repair kit or service assembly, but may also be ordered separately.

**NOTICE:** Except as indicated, items included in repair kits are not sold separately.

**Fig. 7E, Additional Control Box Components**

**Note:** See page 22 for parts list.

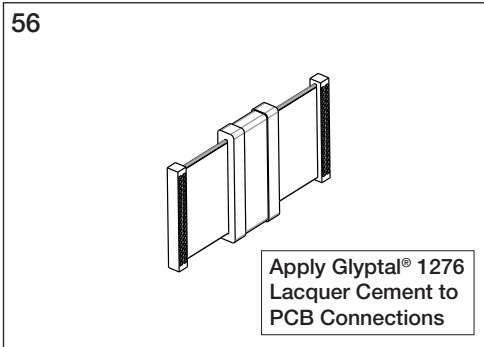
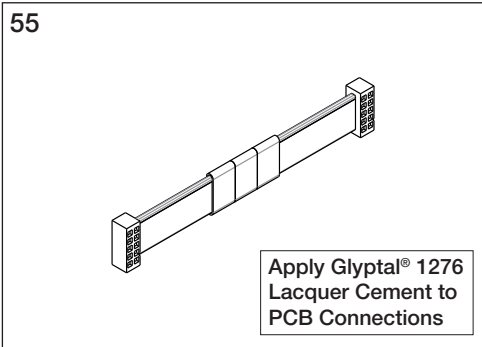
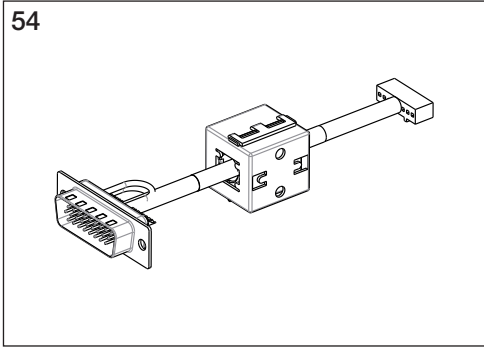
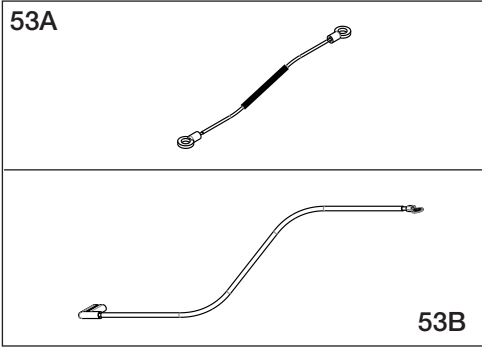
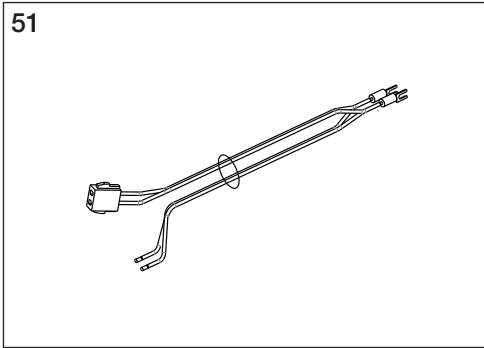
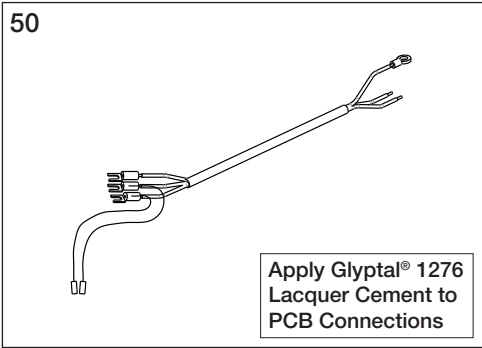
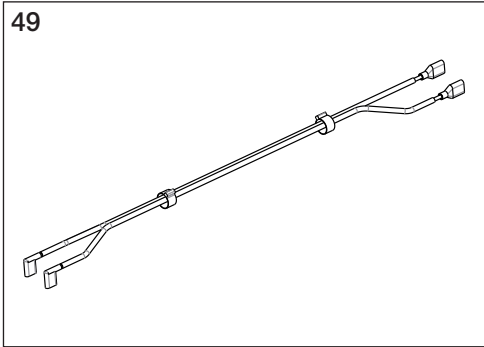
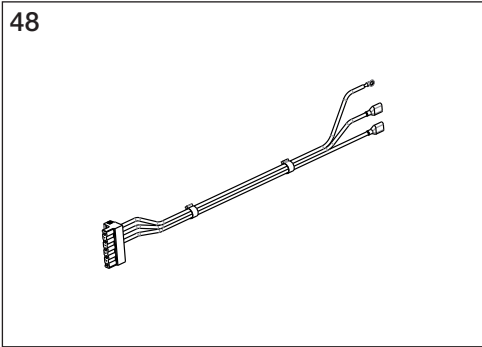

**NOTICE:** Figures 7C and 7F are provided for part identification purposes only. Items are drawn not to scale and may be larger or smaller than actual size.

**Fig. 7F, Additional Control Box Components**

**Note:** See page 22 for parts list.

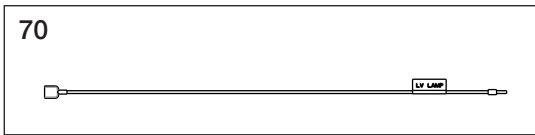
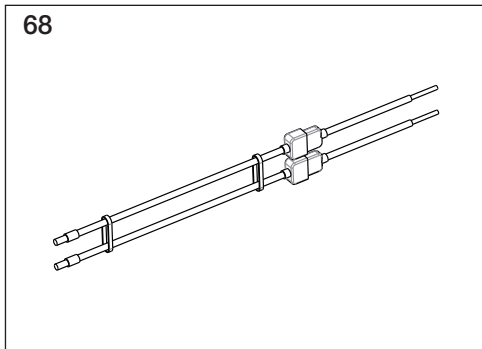
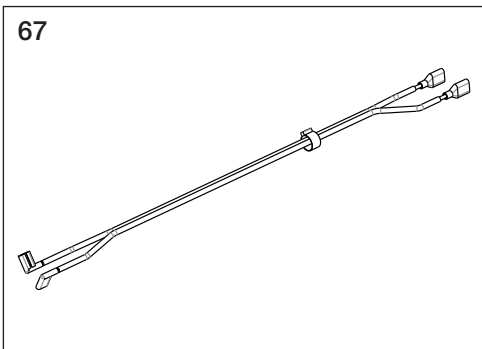
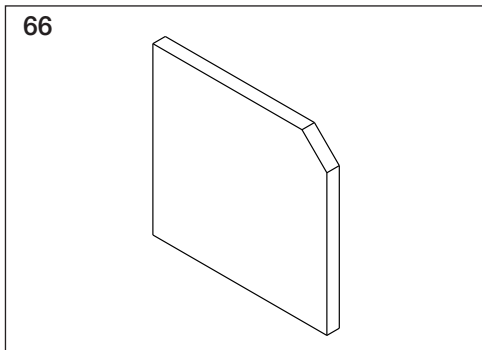
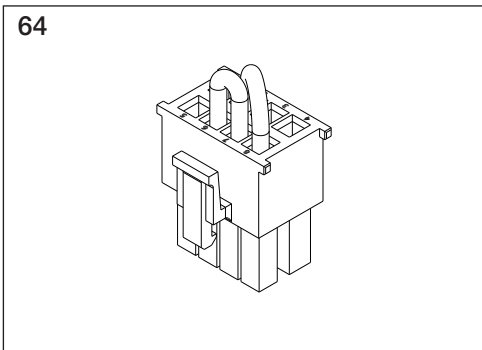
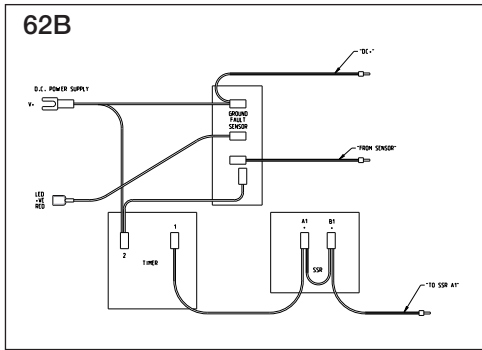
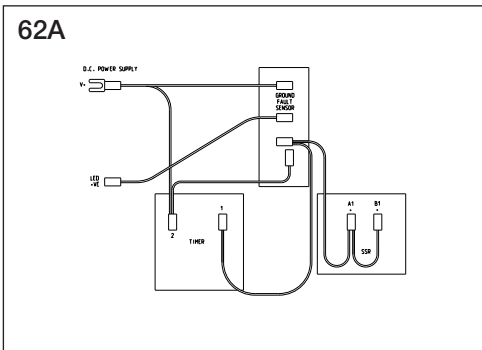
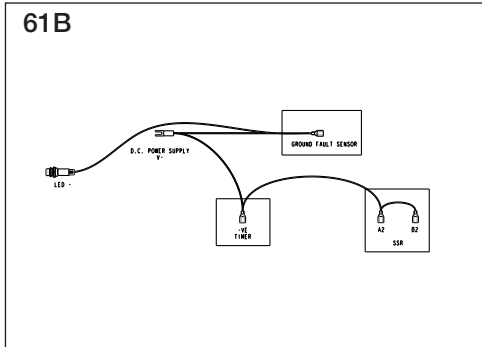
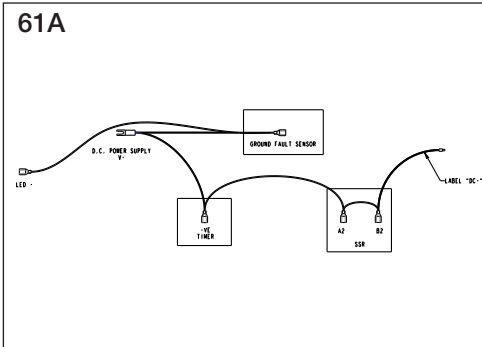

Repair Parts List, Fig. 7E and 7F

L4087

Item	Part Number	Qty.		Description
		115V Models	230V Models	
48	DD3727960	1	1	Power Cable 2
49	DD3728960	1	-	Power Cable 3
50	DD3729960	1	1	Power Cable 4
51	DD3735960	1	1	Power Cable 5
52	* ---	2	2	Flag Connector, Female 1/4 Inch
53A	DD3806960	-	1	Ground Wire, J1
53B	DD3744960	1	-	Ground Wire, J2
54	DD3748960	1	1	Harness, Servo Drive To Adapter PCB
55	DD3749960	1	1	Harness, Ribbon Cable HMI COM 2 to J5
56	DD3776960	1	1	Flat Ribbon Cable, 40 Pin HMI
57	* ---	11	12	Wire Tie, 6" Long
61A	DD6010960	1	-	Wire Harness, DC Control Wires, Set 1
61B	DD5435960	-	1	
62A	DD6011960	1	-	Wire Harness, DC Control Wires, Set 2
62B	DD5436960	-	1	
63	* ---	2	2	Tie Wrap, Black, 8 Inch
64	Ⓢ DD3803380	1	1	Safety Plug
65	* ---	4	4	Wire Tie Mount
66	* Ⓢ Ⓣ DD5675380	1	1	Memory Card, microSD (includes firmware)
67	DD5678960	1	1	Wire Harness
69	* ---	1	2	Pan Hd Philips Mach Screw, 4-40 x 1/4" ZP
70	DD6013960	1	-	Wire Assembly, Low Voltage Lamp, 115V

Notes:

Ⓣ Item included in DD5969900 Touchscreen Repair Kit ETW.

Ⓢ Item included in DD5981900 Servo Drive Repair Kit ETW.

Ⓣ ETW firmware program included on micro SD memory card.

\* Item is not shown and is not available from Enerpac as a repair part (obtain locally).

\* Firmware version of control box must match firmware version of wrench. Always check wrench firmware version whenever replacing the touchscreen panel or the microSD memory card. Contact Enerpac Authorized Service Center for additional information.

**NOTICE:** Except as indicated, items included in repair kits and service assemblies are not sold separately.

# NOTES:

A large rectangular box containing 20 horizontal lines for writing notes.

## Enerpac Worldwide Locations

◆ e-mail: [info@enerpac.com](mailto:info@enerpac.com)

◆ internet: [www.enerpac.com](http://www.enerpac.com)

### Australia and New Zealand

Actuant Australia Ltd.  
P.O. Box 6867  
Wetherhill Park, NSW 1851  
Block V Unit 3  
Regents Park Estate  
391 Park Road  
Regents Park NSW 2143  
Australia  
T +61 287 177 200  
F +61 297 438 648

### Brazil

Power Packer do Brasil Ltda.  
Rua Luiz Lawrie Reid, 548  
09930-760 - Diadema (SP) - Brazil  
T +55 11 5687 2211  
Toll Free: 0800 891 5770

### China (Taicang)

Actuant (China) Industries Co. Ltd.  
No. 6 Nanjing East Road,  
Taicang Economic Dep Zone  
Jiangsu, China  
T +86 0512 5328 7500  
T +86 0512 5335 9690  
Toll Free: +86 400 885 0369

### France, Switzerland, North Africa and French speaking African countries

ENERPAC  
Une division d'Actuant France S.A.S  
Zone Orlytech Bâtiment 516  
1 allée du commandant Mouchotte  
CS 40351  
91550 Paray-Vieille-Poste  
France  
T +33 1 60 13 68 68  
F +33 1 69 20 37 50

### Germany and Austria

Actuant GmbH  
P.O. Box 300113  
D-40401 Düsseldorf  
Willstätterstrasse 13  
D-40549 Düsseldorf, Germany  
T +49 211 471 490  
F +49 211 471 49 28

### India

Actuant India Private Limited  
No. 10, Bellary Road, Sadashivanagar,  
Bangalore, Karnataka 560 080  
India  
T +91 80 3928 9000

### Italy

ENERPAC S.p.A.  
Via Canova 4  
20094 Corsico (Milano)  
T +39 02 4861 111  
F +39 02 4860 1288

### Japan

Enerpac Co., Ltd.  
Besshocho 85-7  
Kita-ku, Saitama-shi 331-0821, Japan  
T +81 48 662 4911  
F +81 48 662 4955

### Middle East, Egypt and Libya

ENERPAC Middle East FZE  
Plot M00737m 1242nd Street  
Jebel Ali Free Zone North  
P.O. Box 18004, Dubai  
United Arab Emirates  
T +971 (0)4 8872686  
F +971 (0)4 8872687

### Russia

Rep. office Enerpac  
Russian Federation  
Admiral Makarova Street 8  
125212 Moscow, Russia  
T +7 495 98090 91  
F +7 495 98090 92

### Norway

Sales Office Norway  
Unit 524, Nydalsveien 28, 0484 Oslo  
P.O. Box 4814, Nydalen 0422 Oslo  
Norway  
T +47 91 578 300

### Southeast Asia, Hong Kong and Taiwan

Actuant Asia Pte Ltd.  
83 Joo Koon Circle  
Singapore 629109  
T +65 68 63 0611  
F +65 64 84 5669  
Toll Free: +1800 363 7722

### South Korea

Actuant Korea Ltd.  
3Ba 717, Shihwa Industrial Complex  
Jungwang-Dong, Shihung-Shi,  
Kyunggi-Do  
Republic of Korea 429-450  
T +82 31 434 4506  
F +82 31 434 4507

### Spain and Portugal

ENERPAC SPAIN, S.L.  
Avda. Valdeparra N° 27 3ª - L8  
28108 Alcobendas (Madrid), Spain  
T +34 91 884 86 06  
F +34 91 884 86 11

### Sweden, Denmark

**Finland and Iceland**  
Enerpac Scandinavia AB  
Kopparlundsvägen 14,  
721 30 Västerås  
Sweden  
T +46 (0) 771 41 50 00

### The Netherlands, Belgium, Luxembourg, Central and Eastern Europe, Baltic States, Greece, Turkey and CIS countries

ENERPAC B.V.  
Galvanistraat 115, 6716 AE Ede  
P.O. Box 8097, 6710 AB Ede  
The Netherlands  
T +31 318 535 911  
F +31 318 535 848

### Enerpac Heavy Lifting Technology B.V.

Spinelstraat 15, 7554 TS Hengelo  
P.O. Box 421, 7550 AK Hengelo  
The Netherlands  
T +31 74 242 20 45  
F +31 74 243 03 38

### South Africa and other English speaking African countries

Enerpac Africa Pty Ltd.  
No. 5 Bauhinia Avenue  
Cambridge Office Park  
Block E  
Highveld Techno Park  
Centurion 0157  
Republic of South Africa  
T: +27 12 940 0656

### United Kingdom and Ireland

ENERPAC UK Ltd.  
5 Coopies Field  
Morpeth, Northumberland  
NE61 6JR, England  
T +44 1670 5010 00

### USA, Latin America and Caribbean

ENERPAC World Headquarters  
P.O. Box 3241  
Milwaukee WI 53201-3241 USA  
N86 W12500 Westbrook Crossing  
Menomonee Falls, Wisconsin 53051  
T +1 262 293 1600  
F +1 262 293 7036  
User inquiries:  
T +1 800 433 2766  
Distributor inquiries/orders:  
T +1 800 558 0530  
F +1 800 628 0490

All Enerpac products are  
guaranteed against defects  
in workmanship and materials  
for as long as you own them.

For the location of your nearest  
authorized Enerpac Service Center,  
visit us at [www.enerpac.com](http://www.enerpac.com)

040717

# ENERPAC

Visit [www.enerpac.com](http://www.enerpac.com) for the location of the  
Enerpac Authorized Service Center nearest you.