

Document Number	Revision	Revision Date	Product Date Code Beginning With
L4283	Rev. B	04/2021	F

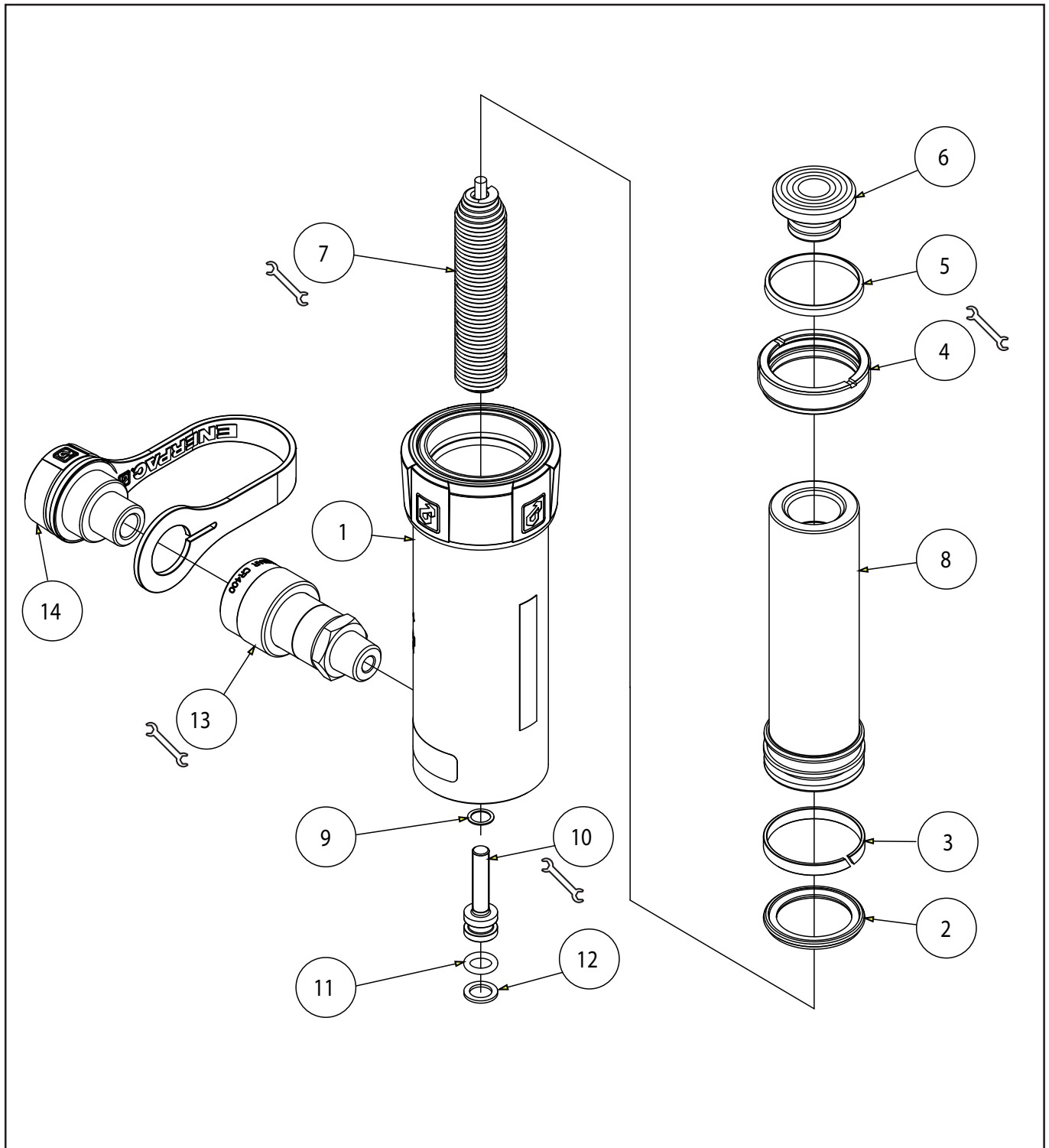

Figure 1, RC Hydraulic Cylinder, 10 Ton

Repair Parts List, Figure 1

Item	Description	Qty	RC101	RC102	RC104
1	Base	1	N/A	N/A	N/A
2	Piston Seal	1	▲ ●	▲ ●	▲ ●
3	Wear Band, Plunger	1	▲ ★	▲ ★	▲ ★
4	Stop Ring	1	RC10044	RC10044	RC10044
5	Wiper	1	▲ ✘	▲ ✘	▲ ✘
6	Saddle Assembly	1	N/A	A102G	A102G
7	Spring Assembly	1	RC10K31	RC10K31	RC10K32
8	Plunger	1	RC101040	RC102040	RC104040
9	Copper Gasket	1	▲ ■	▲ ■	▲ ■
10	Screw, Socket Head	1	▲ ■	▲ ■	▲ ■
11	O-Ring	1	▲ ■	▲ ■	▲ ■
12	Backup, Split	1	▲ ■	▲ ■	▲ ■
13	Coupler	1	CR400	CR400	CR400
14	Dust Cap ▲	1	CD411	CD411	CD411
N/S	O-ring, coupler	1	▲	▲	▲
N/S	Enerpac Decal	1	▲	▲	▲
N/S	Warning Decal	1	▲	▲	▲
N/S	O-ring, saddle	1	N/A	▲	▲
N/S	Thread Protector	1	▲	▲	▲

Notes:

- ▲ Indicated item included in and available as a part of the Repair Kit RC10NK0
- Indicated item included in and available as a part of the Spring Assembly
- Indicated item included in and available as packs of 10 units in Seal Kit RC10NKS (see below)
- ★ Indicated item included in and available as packs of 10 units in Wear Band Kit Plunger RC10NKB1 (see below)
- ✘ Indicated item included in and available as packs of 10 units in Wiper Kit RC10NKW (see below)

●★✘ Kits only available in America



Item nr.	Torque/ remark
4	Secure with Loctite 222 and torque to 70-90 in-lbs [7.9-10.2 Nm]
7	Torque to 48-60 in-lbs [5.4-6.8 Nm]
10	Torque to 90-110 in-lbs [10.2-12.4 Nm]
13	Torque to 40-60 ft-lbs [54-81 Nm]
	Use Loctite 545 or Teflon Tape