

Document Number	Revision	Revision Date	Product Date Code Beginning With
L4292	Rev. B	04/2021	A (RC1002) E (RC1006 & 10010)

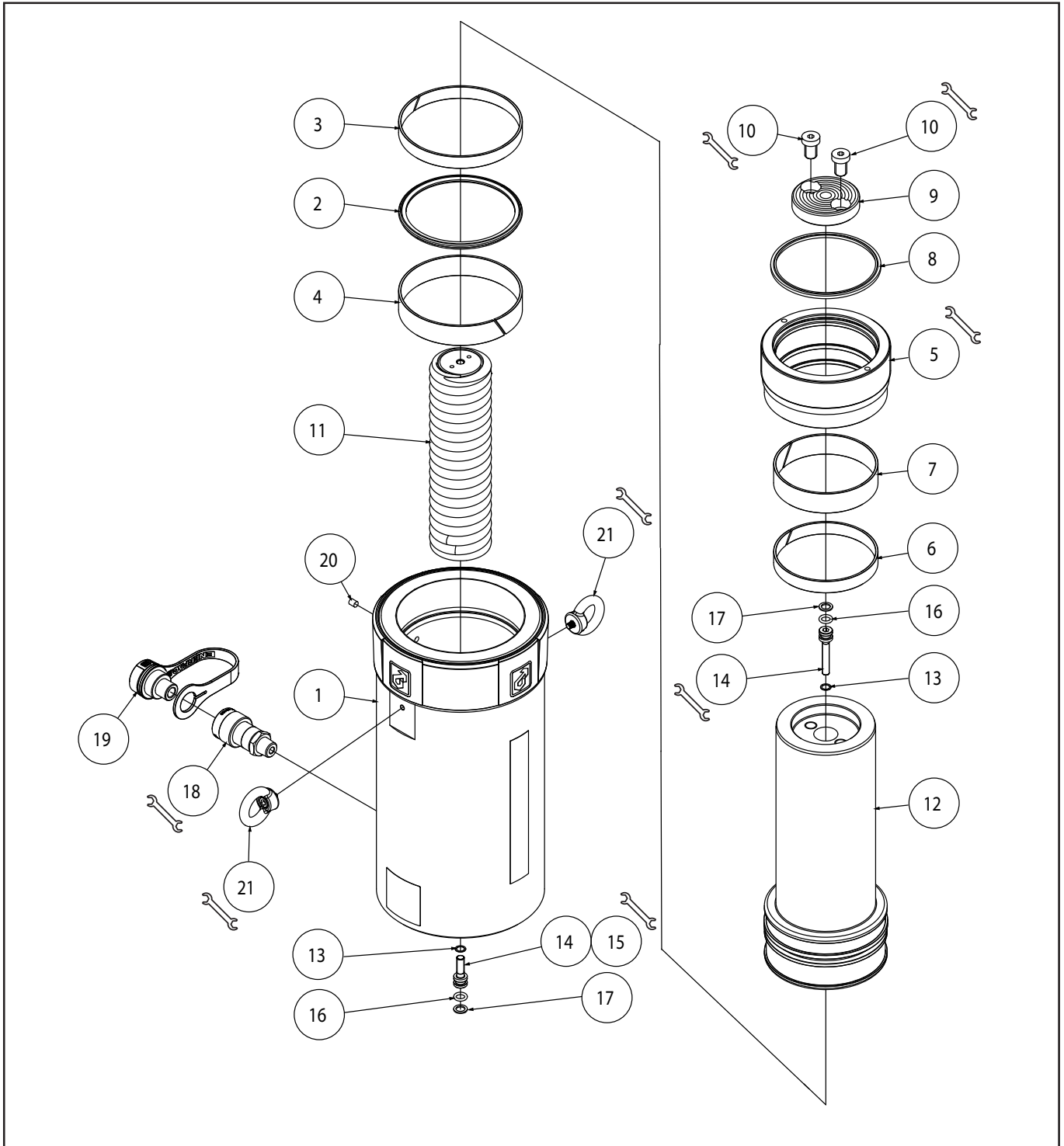

Figure 1, RC Hydraulic Cylinder, 100 Ton

Repair Parts List, Figure 1

Item	Description	Qty	RC1002	Qty	RC1006	Qty	RC10010
1	Base	N/A	N/A	N/A	N/A	N/A	N/A
2	Piston Seal	1	▲ ●	1	▲ ●	1	▲ ●
3	Wear Band, Plunger	0	N/A	1	▲ ★	1	▲ ★
4	Wear Band, Plunger	1	▲ ◆	1	▲ ◆	1	▲ ◆
5	Stop Ring	1	RC100044	1	RC100044	1	RC100044
6	Wear Band, Stop Ring	1	▲ *	1	▲ *	1	▲ *
7	Wear Band, Stop Ring	1	▲ ⊛	1	▲ ⊛	1	▲ ⊛
8	Wiper	1	▲ ✕	1	▲ ✕	1	▲ ✕
9	Saddle	1	HCL50045	1	HCL50045	1	HCL50045
10	Screw, Low Head Socket .50-13 x .75"	2	▲	2	▲	2	▲
11	Spring Assembly	1	RC100NKS1	1	RC100NKS2	1	RC100NKS3
12	Plunger	1	RC1002040	1	RC1006040	1	RC10010040
13	Copper Gasket	2	▲ ■	2	▲ ■	2	▲ ■
14	Screw, Socket Head	2	▲ ■	1	▲ ■	1	▲ ■
15	Screw, Spring	0	N/A	1	▲ ■	1	▲ ■
16	O-Ring	2	▲ ■	2	▲ ■	2	▲ ■
17	Backup, Split	2	▲ ■	2	▲ ■	2	▲ ■
18	Coupler	1	CR400	1	CR400	1	CR400
19	Dust Cap ▲	1	CD411	1	CD411	1	CD411
20	Filter	1	▲	1	▲	1	▲
21	Lifting Eye	2	DB8099667	1	DB8099667	1	DB8099667
N/S	O-ring, coupler	1	▲	1	▲	1	▲
N/S	Enerpac Decal	1	▲	1	▲	1	▲
N/S	Warning Decal	1	▲	1	▲	1	▲
N/S	Thread Protector	1	▲	1	▲	1	▲

Notes:

- ▲ Indicated item included in and available as a part of the Repair Kit RC100NK0
- Indicated item included in and available as a part of the Spring Assembly
- Indicated item included in and available as packs of 10 units in Seal Kit RC100NKS (see below)
- ★ Indicated item included in and available as packs of 10 units in Wear Band Kit Plunger RC100NKB1 (see below)
- ◆ Indicated item included in and available as packs of 10 units in Wear Band Kit Plunger RC100NKB2 (see below)
- * Indicated item included in and available as packs of 10 units in Wear Band Kit Stop Ring RC100NKB3 (see below)
- ⊛ Indicated item included in and available as packs of 10 units in Wear Band Kit Stop Ring RC100NKB4 (see below)
- ✕ Indicated item included in and available as packs of 10 units in Wiper Kit RC100NKW (see below)

●★◆*⊛✕ Kits only available in America



Item nr.	Torque/ remark
5, 21	Secure with Loctite 222 and torque to 70-90 in-lbs [7.9-10.2 Nm]
10	Torque to 15-25 ft-lbs [20-34 Nm]
14, 15	Torque to 90-110 in-lbs [10.2-12.4 Nm]
18	Torque to 40-60 ft-lbs [54-81 Nm]
	Use Loctite 545 or Teflon Tape