

Document Number	Document Revision	Document Revision Date	Product Date Code Beginning With
L4348	A	04/2019	A

To Protect Your Warranty, Use Only ENERPAC Hydraulic Oil.

Enerpac recommends that all kit components be installed to insure optimum performance of the repaired product.

Models:

- EP3204JB (110-120 VAC - NEMA 5-15 plug)
- EP3204JI (200-250 VAC - NEMA 6-15 plug)
- EP3204JE (200-250 VAC - Schuko CEE 7/7 plug)

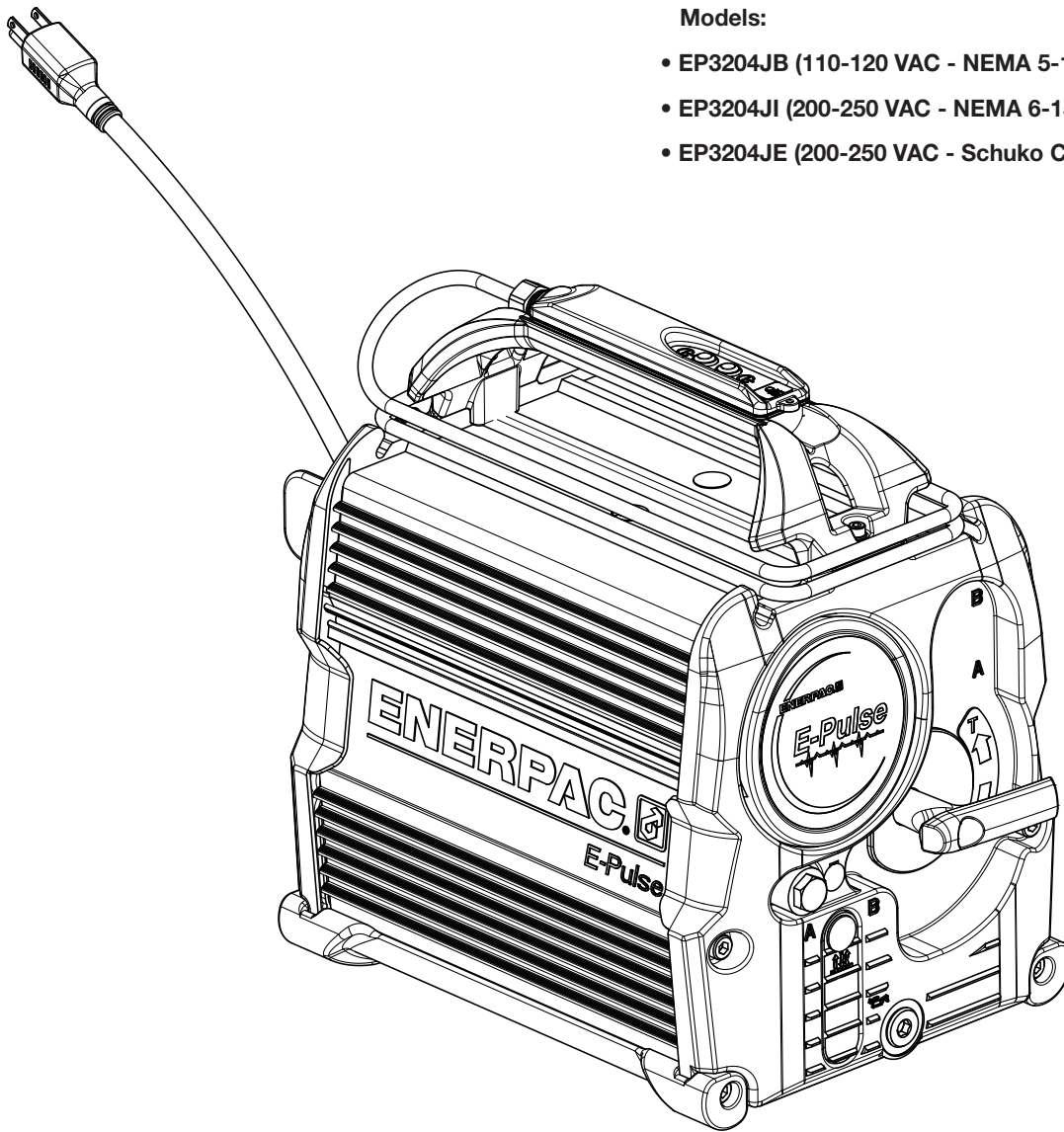

⚠ WARNING Fully relieve hydraulic pressure, disconnect hydraulic hoses and unplug AC power cord from electrical outlet before beginning any inspection, maintenance or repair procedures. Failure to observe these precautions could result in death or serious personal injury. Appropriate shop safety procedures are to be followed during disassembly and reassembly to minimize any possibility of injury.

Table of Contents:

	Page
Figure 1 - Pump Exterior	3
Figure 1A - Speed Control Potentiometer and Cable Kit	4
Figure 2 - Miscellaneous Assemblies	5
Figure 2A - DC Power Cable Assembly	6
Figure 2B - Serial Communication Cable Assembly	6
Figure 2C - Jumper Connection	6
Figure 2D - Pump Handle Kit	7
Figure 2E - 2 Button, Pendant Assembly	8
Figure 3 - Motor Controller Cover Assembly	9
Figure 4 - Power/App Assembly	10
Figure 5 - Motor Stator and Pump Assembly	11
Figure 5A - Flareless Tube Kit - A Port	13
Figure 5B - Motor Replacement Kit	13
Figure 5C - Bulkhead Fitting Kit	14
Figure 6 - Reservoir and End Cap Assembly	14
Figure 7 - Rear End Cap Assembly	15
Figure 7A - Power Cord Replacement Kit	17
Figure 8 - Front End Cap Assembly	18
Figure 8A - Water Ingress Seal Kit	19
Figure 9 - Housing Assembly	20
Figure 9A - Eccentric Kit	21
Figure 9B - Pump Housing Kit	22
Figure 9C - Piston Block Assembly Kit	24
Figure 9D - Piston Block Seal Kit	25
Figure 9E - Intake Suction Filter Kit	25
Figure 10 - Direct Drive Pump Assembly	26
Figure 10A - Rebuild Kit, User-Adjustable Relief Valve	27
Figure 11 - 3/2 Manual Valve Assembly	28
Figure 11A - 3/2 Manual Valve Kits	29
Figure 12 - Hydraulic Schematic Diagram	30
Figure 13 - Electrical Wiring Diagram	31
Figure 14 - Pump Cover Removal/Installation Instructions	32



Notes:

- Parts lists indicate the total quantity of each part used in a figure.
- The quantity of a part supplied in a repair kit or service assembly may be less than the total quantity shown in the parts list.
- Information contained in this document is subject to change without notice due to design variables, product improvements and other factors. Copyright © 2019 Enerpac. All rights reserved.

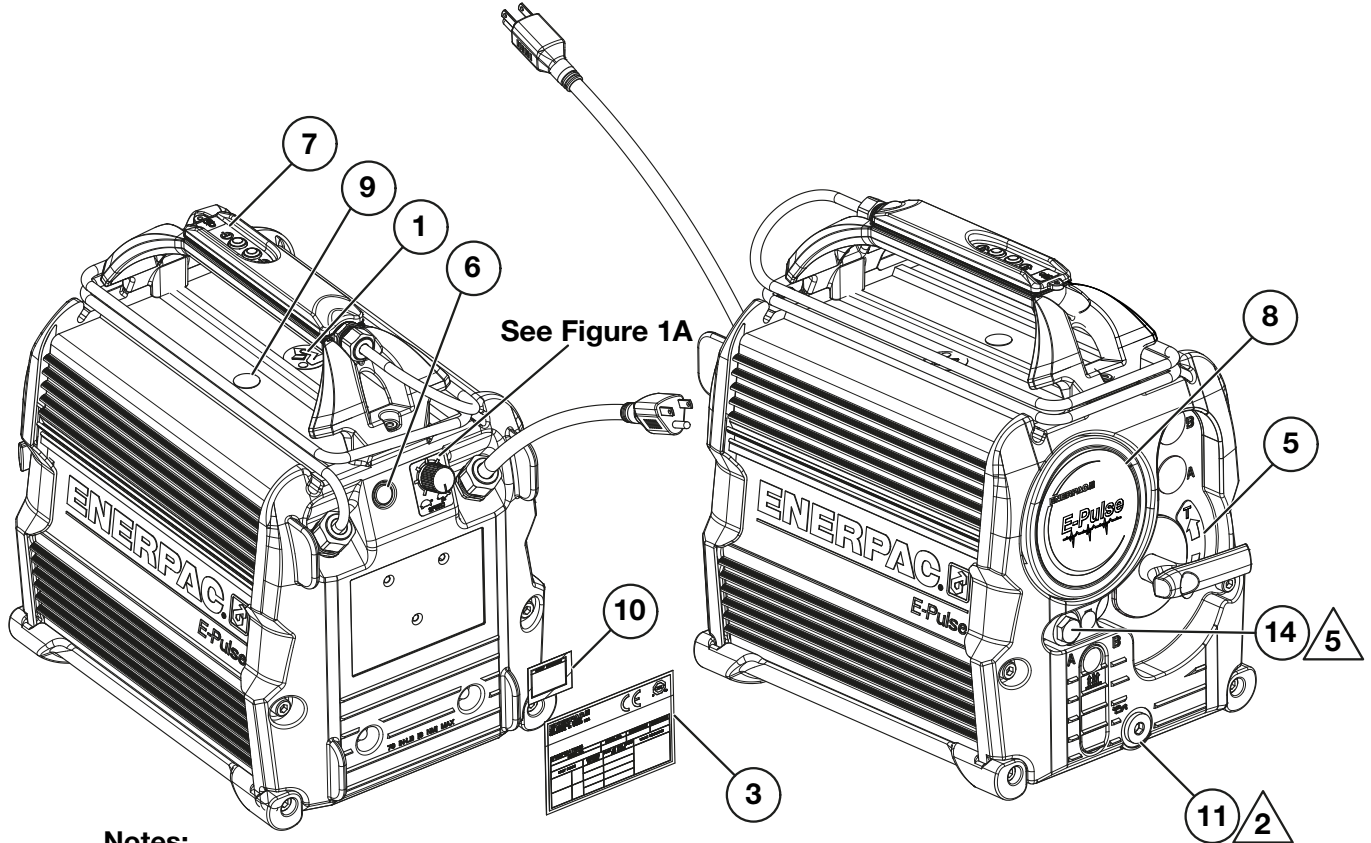
Figure 1 - Pump Exterior



Notes:

-  Torque to 13-16 ft-lbs [18-22 Nm].
-  Torque to 10-12 ft-lbs [14-16 Nm].

Repair Parts List for Figure 1			
Item	Part Number	Qty.	Description
1	* DC7887026	1	CE Safety Label Read Instructions
3	DD6799026	1	Decal, Product Specification
5	DD7216026	1	Decal, Manual Valve Operation
6	DD7248009	1	Plug, Dome, 7.5 Dia
7	DD7349026	1	Decal, Pendant, Momentary/Continuous
8	DD7355026	1	Decal, Gauge Cap
9	DD7417026	1	Decal, Unplug Cord
10	DD7441026	1	Decal, Valve Schematic, 3/2M
11	DD7557006	1	Plug, SAE #8, Zero-Leak
14	R515245-2	1	Plug

* - Included in Pump Cover Kit DD6792098SR.

Figure 1A - Speed Control Potentiometer and Cable Kit: DD7060960K

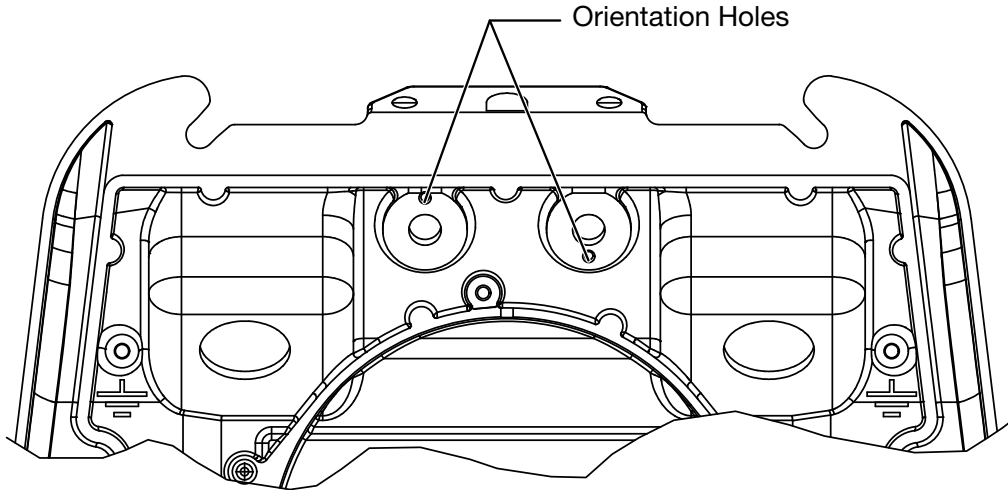

See Figure 13 for main electrical wiring diagram.

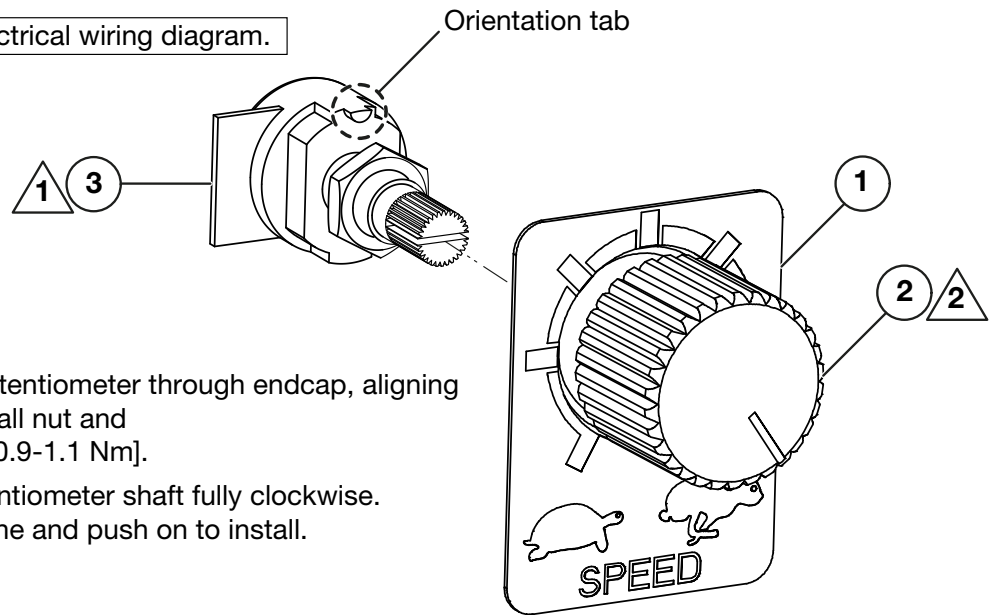

Notes:

- 1 Remove nut. Insert potentiometer through endcap, aligning orientation tab. Reinstall nut and torque to 8-10 in-lbs [0.9-1.1 Nm].
- 2 Apply decal, turn potentiometer shaft fully clockwise. Align knob with max line and push on to install.

Wiring Diagram

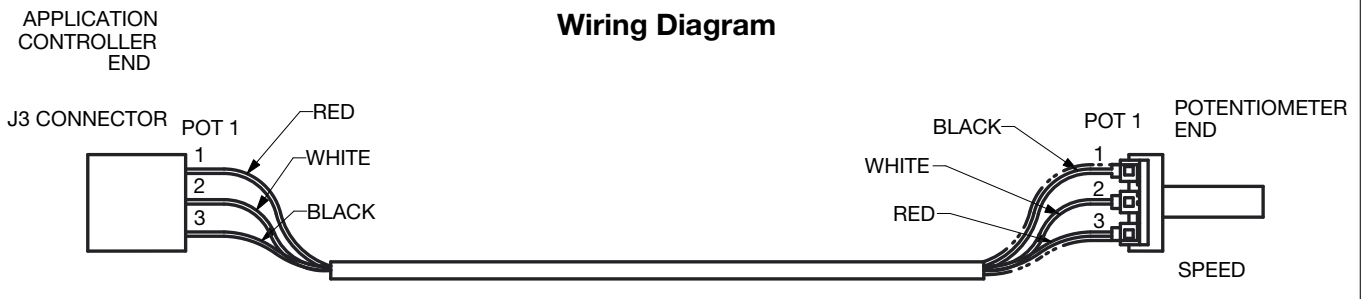

Repair Parts List for Figure 1A

Item	Part Number	Qty.	Description
1	DD6798026	1	Decal, Potentiometer, Speed Control
2	DD7029020	1	Knob Potentiometer
3	DD7060960	1	Cable Assembly

Note: Speed Control Potentiometer and Cable Kit DD7060960K includes all items listed in the table above.

Figure 2 - Miscellaneous Assemblies

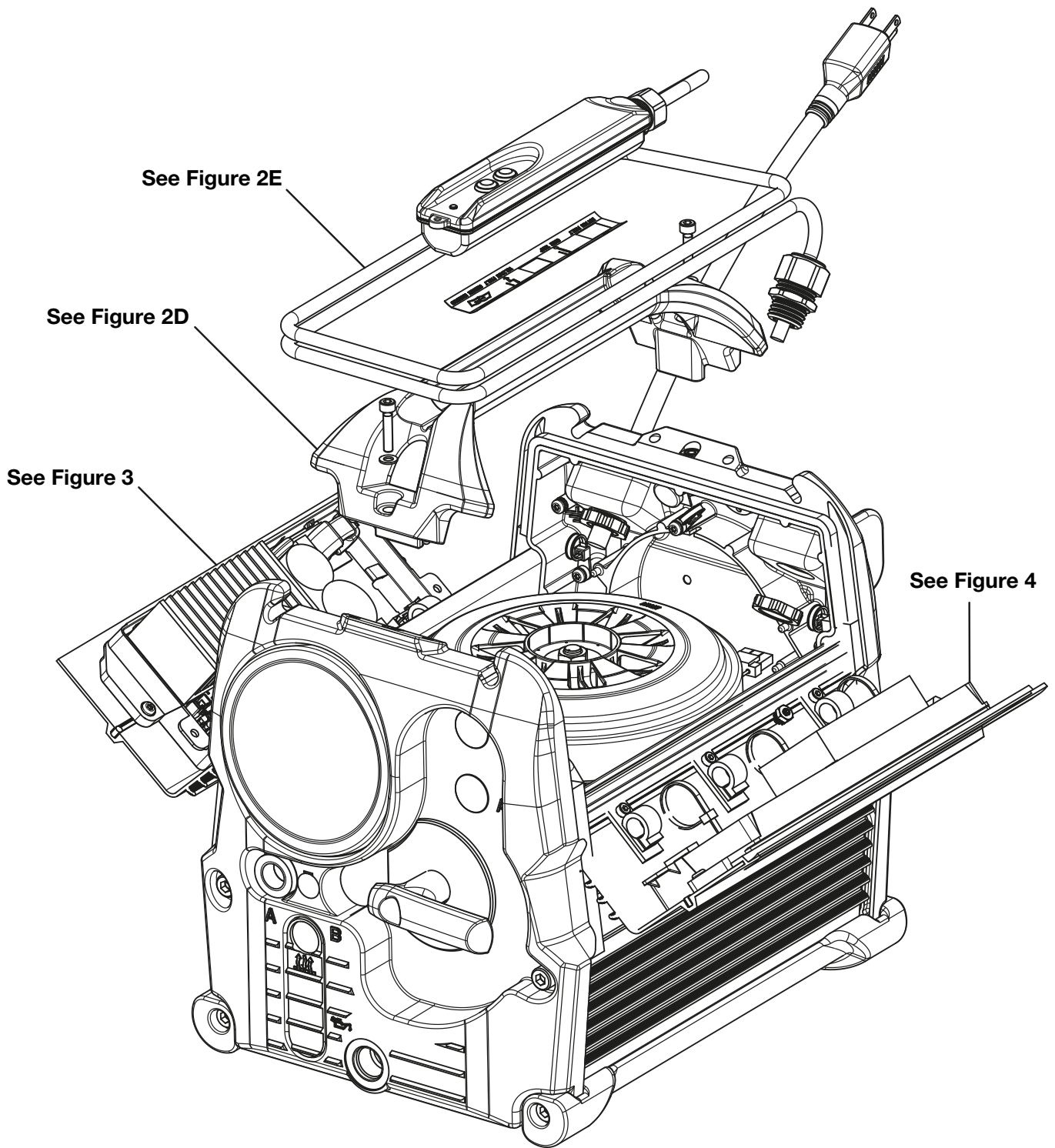

Refer to Figures 2A through 2C
for electrical cable assemblies.

Figure 2A - DC Power Cable Assembly: DD7061960

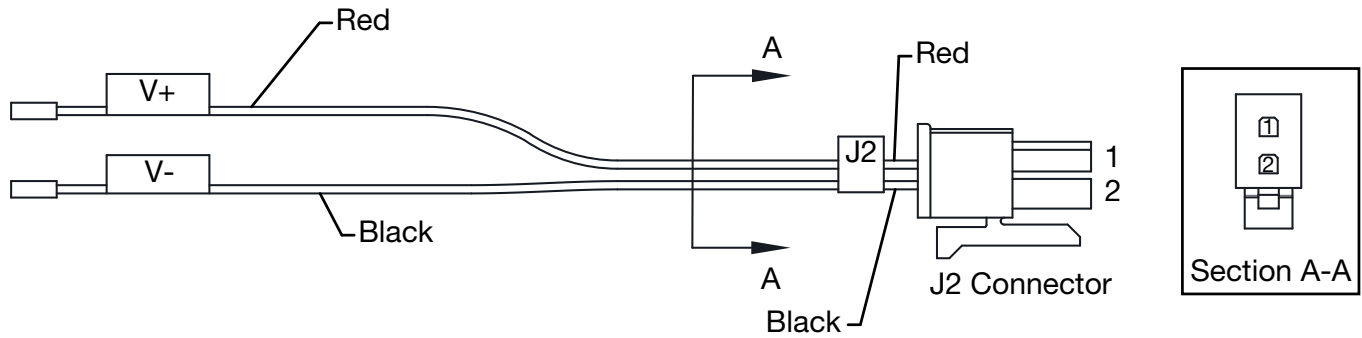

Figure 2C - Serial Communications Cable Assembly: DD7064960

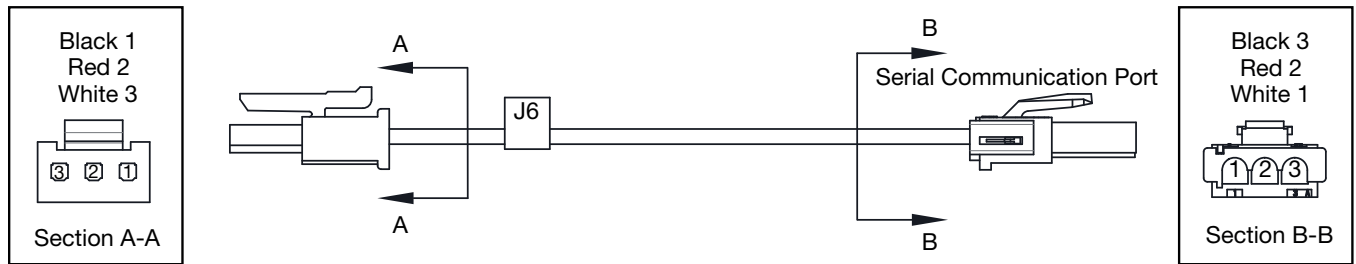
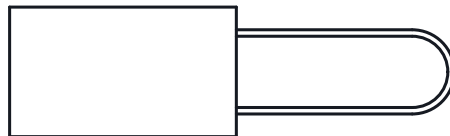

Figure 2C - Jumper Connection: DD7125960



Repair Parts List for Figure 2A, 2B and 2C

Item	Part Number	Qty.	Description
---	See Figure 2A	1	Cable Assembly, DC Power Supply
---	See Figure 2B	1	Cable Assembly, Serial Communications
---	See Figure 2C	1	Cable, Jumper, J8 and J9 Connection
---	DC9876647	3	Black Cable Tie 6" (<i>not shown</i>)

Figure 2D - Pump Handle Kit: DD5789800SR

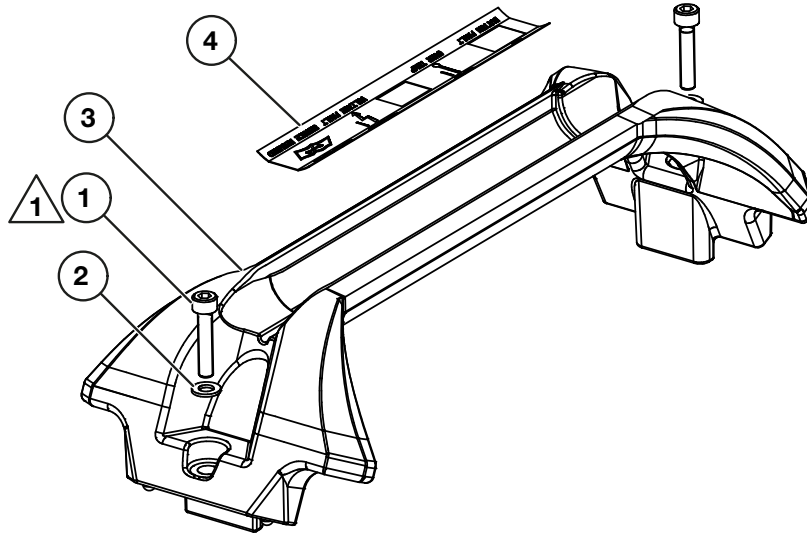

Note:

 Torque to 42-47 in-lbs [4.7-5.3 Nm].

Repair Parts List for Figure 2D

Item	Part Number	Qty.	Description
1	CAE1050108-1A	2	Flat Washer DIN125A M5
2	CCE523028-1A	2	Screw-SHCS, Hex, M5 x 0.8 x 25, 12.9, Zinc
3	DD6789800	1	Casting Handle Pump
4	DD7167026	1	Decal, Troubleshoot

Note: Pump Handle Kit DD5789800SR includes all items listed in the table above.

Figure 2E - 2 Button, Pendant Assembly: DD5278900SR1

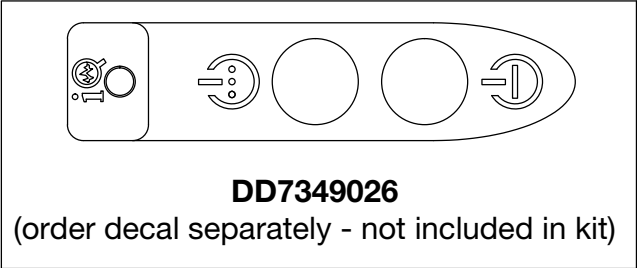
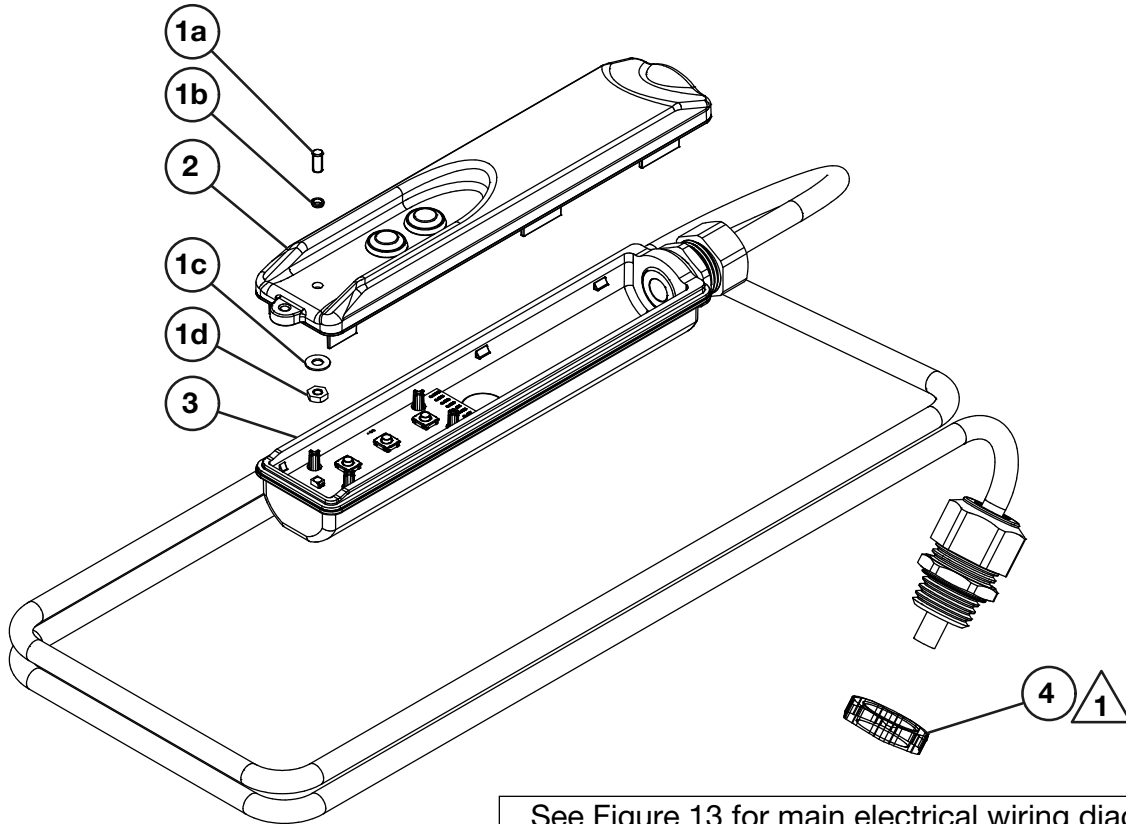

Note:

 Torque to finger tight plus an additional 1/4 turn.

Repair Parts List for Figure 2E			
Item	Part Number	Qty.	Description
1a	DD7094380	1	Light Pipe
1b			Seal
1c			Washer
1d			Nut
2	DD7280424	1	Cover
3	DD7294960	1	Bottom
4	DC9538021	1	Locking Nut 20mm

Note: 2 Button, Pendant Assembly DD5278900SR1 includes all items listed in the table above.

Figure 3 - Motor Controller Cover Assembly

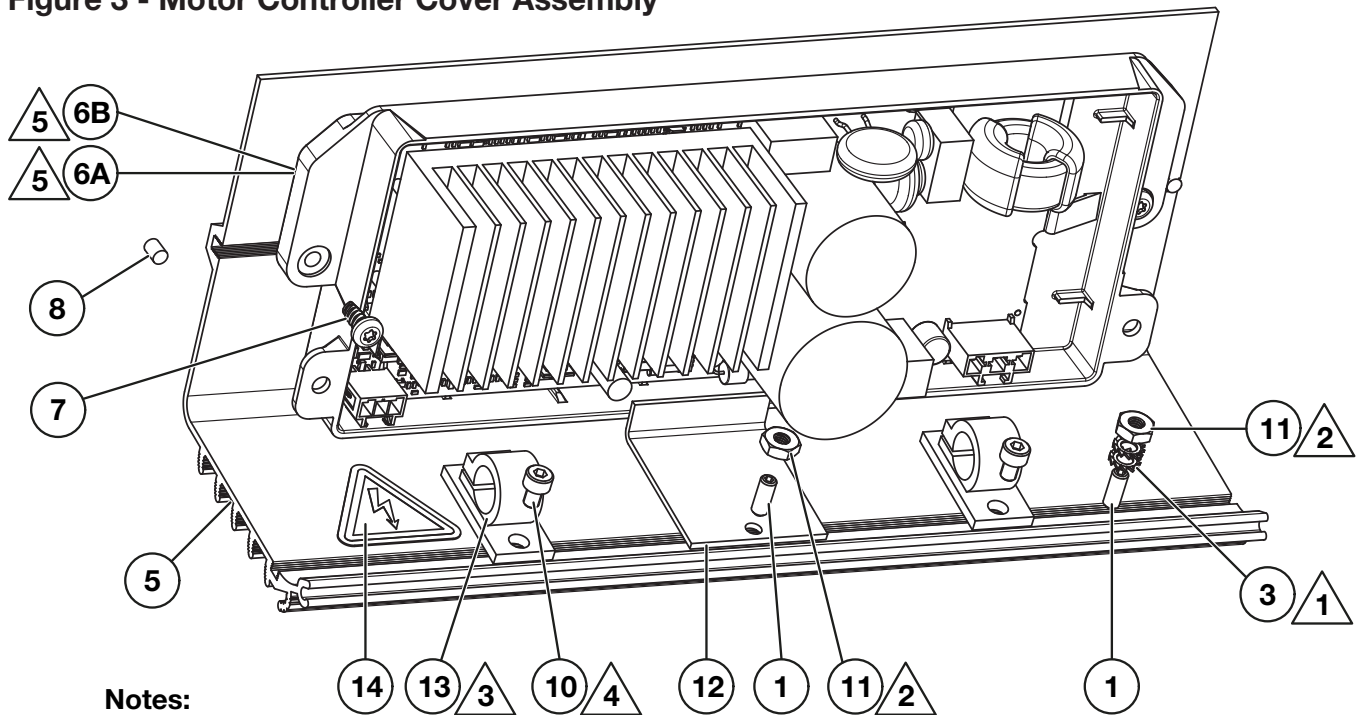

Notes:

- ▲ 1 Install ground cable with ring terminal between star washers.
- ▲ 2 Torque to 8-10 in-lbs [0.9-1.1 Nm].
- ▲ 3 Remove adhesive backing before installation.
- ▲ 4 Torque to 6-7 in-lbs [0.7-0.8 Nm].
- ▲ 5 See parts list (items 6A & 6B) for voltage options.

- Attach all wires including ground wire!
- Remove lip seal from old cover and attach to new cover if applicable (only one side has a lip seal).
- See wiring diagram Figure 13 for wire connections.
- See pump cover removal/installation instructions Figure 14.

Repair Parts List for Figure 3

Item	Part Number	Qty.	Description
1	BF1607027AX	2	Set Screw, #8-36 x 0.438, Cup Point, Zinc
3	CCE1040108-7A	2	Lock Washer, External Tooth For M4
5	* DD6792098-P03	1	Pump Cover
6A	DD6987827K	1	Motor Controller Kit, 120V (Model EP3204JB)
6B	DD7318827K	1	Motor Controller Kit, 230V, 240V (Models EB3204Jl and EP3204JE)
7	▲ DD7513001	2	Screw, Thread Forming, M4.55 x 10 Long
8	* DD7462037	2	Gasket, 4.0mm Dia x 5.50mm L Cord Stock
---	* See Figure 1	1	CE Safety Label Read Instructions
10	* CBE411028-1A	3	Screw-SHCS, Hex, M4 x 0.7 x 6, 8.8, Zinc
11	DD7516122	2	Nut-Hex Full, #8-36, GRD 2, Zinc
12	DD7609111	1	Bracket, Motor Controller Restraint
13	* DD7326217	3	Cable Tie, Screw Mount
14	* DC9922026	1	Decal High Voltage

▲ - Each motor controller kit (items 6A and 6B) includes two thread forming screws (item 7).
 * - Included in Pump Cover Kit DD6792098SR.

Figure 4 - Power/App Assembly

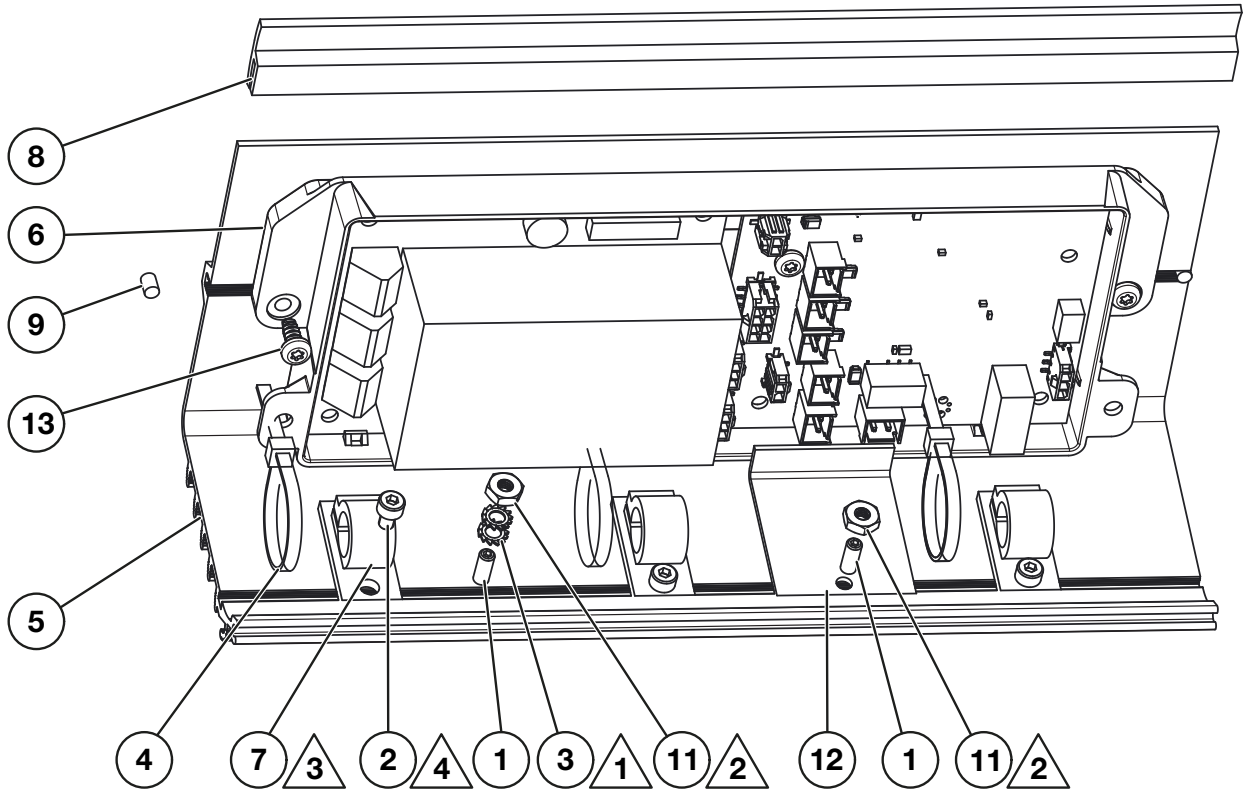

Notes:

- △ 1 Install ground cable with ring terminal between star washers.
- △ 2 Torque to 8-10 in-lbs [0.9-1.1 Nm].
- △ 3 Remove adhesive backing before installation.
- △ 4 Torque to 6-7 in-lbs [0.7-0.8 Nm].

Repair Parts List for Figure 4			
Item	Part Number	Qty.	Description
1	BF1607027AX	1	Set Screw, #8-36 x 0.438, Cup Point, Zinc
2	* CBE411028-1A	3	Screw-SHCS, Hex, M4 x 0.7 x 6, 8.8, Zinc
3	CCE1040108-7A	2	Lock Washer, External Tooth For M4
4	DC9876647	3	Black Cable Tie 6"
5	* DD6792098-P03	1	Cover, Machined, 1 Gal, Yellow
6	DD7298900	1	Power App Board Assembly
7	* DD7326217	3	Cable Tie, Screw Mount
8	DD7448037	1	Lip Seal, E-Pulse
9	* DD7462037	2	Gasket, 4.0mm Dia x 5.50mm L Cord Stock
11	DD7516122	1	Nut-Hex Full, #8-36, GRD 2, Zinc
12	DD7609111	1	Bracket, Motor Controller Restraint
13	DD7513001	2	Screw, Thread Forming, M4.55 x 10 Long
---	* See Figure 1	1	Decal, Unplug Cord (<i>not shown</i>)

* - Included in Pump Cover Kit DD6792098SR.

Figure 5 - Motor Stator Assembly

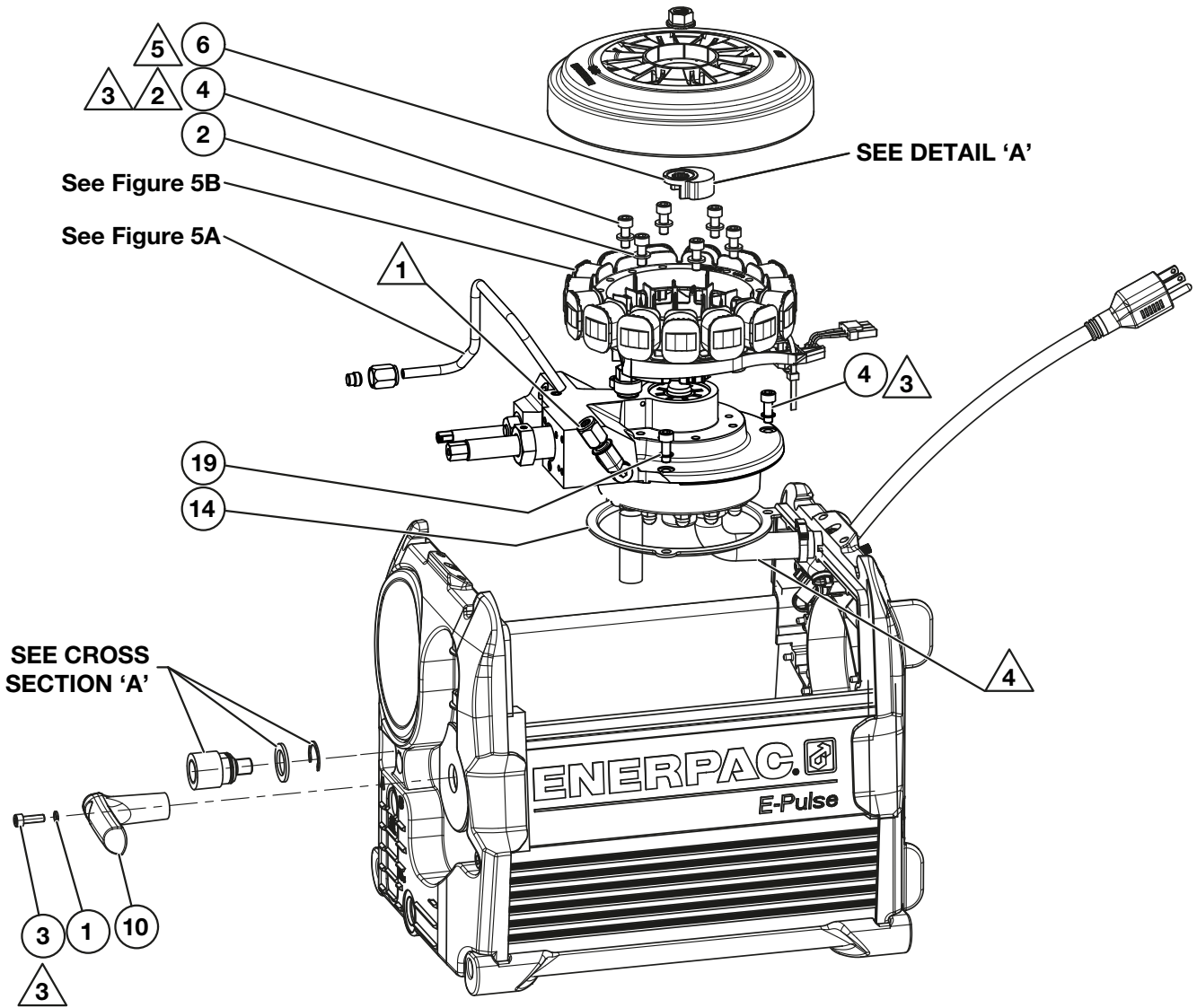

DETAIL 'A' - COUNTERWEIGHT ORIENTATION

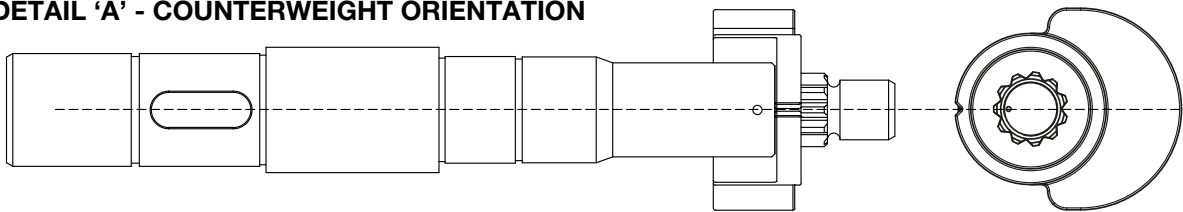

Notes:

- ▲ 1 Insert tubes and torque to 150-160 in-lbs [203-217 Nm].
(At manifold end prior to installing pump into reservoir)
- ▲ 2 Apply Loctite 243.
- ▲ 3 Torque to 42-47 in-lbs [4.7-5.3 Nm].
- ▲ 4 Bend tube vertical while installing pump into reservoir.
- ▲ 5 Align mark on counterweight with mark on shaft. (See detail A)

CROSS SECTION 'A' (Figure 5)

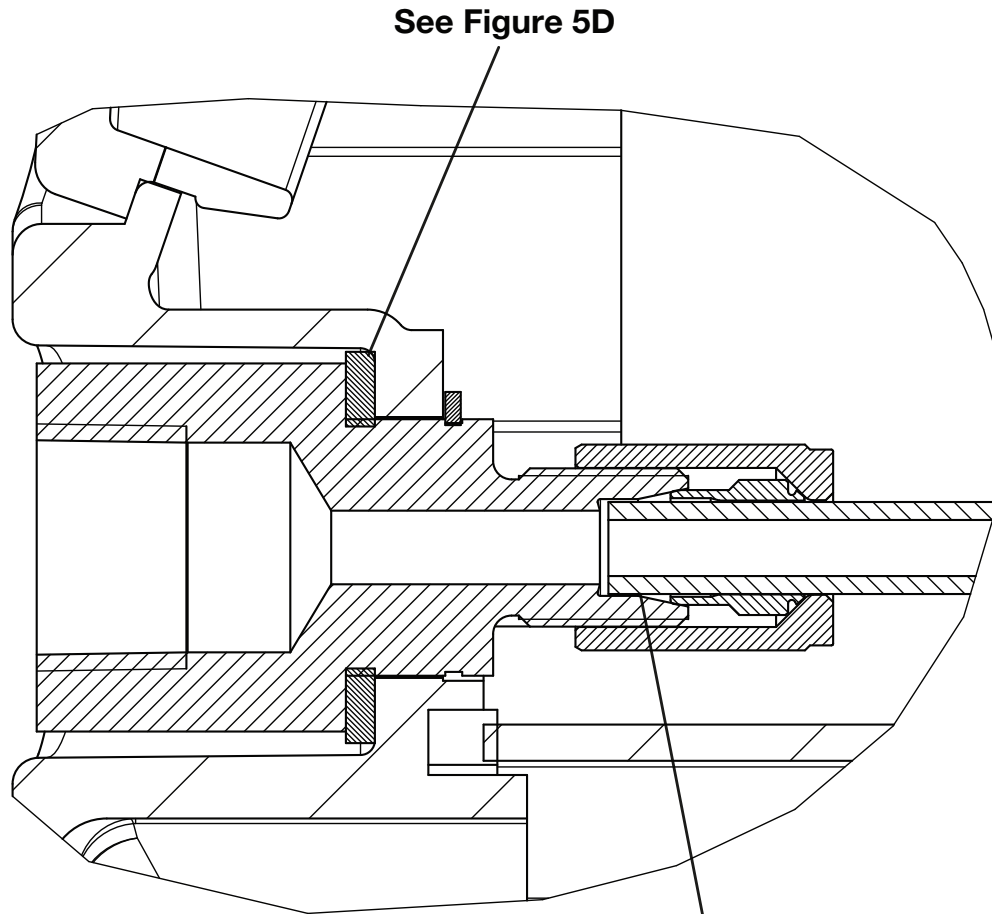

**ORIENT FERRULE FOR COMPRESSION
FITTING WITH SMALL OD TOWARD
TUBE END**

Repair Parts List for Figure 5

Item	Part Number	Qty.	Description
1	B1086066	1	Lockwasher
2	CAE1060108-1A	6	Washer-Flat, M6, 6.4 ID x 12 OD x 1.6, Din 125A, Zinc
3	CBE519028-1A	1	Screw-SHCS, Hex, M5 x 0.8 x 16, 8.8, Zinc
4	CBE619028-1A	9	Screw-SHCS, Hex, M6 x 1 x 16, 8.8, Zinc
6	DD6763101	1	Plate, Counterweight
10	DD7027070	1	Handle, Valve
14	DD7319037	1	Gasket, Manifold
19	S3037	3	Gasket

Figure 5A - Flareless Tube Kit - A Port: DD7038268SR

Item pre-assembled prior to shipment.

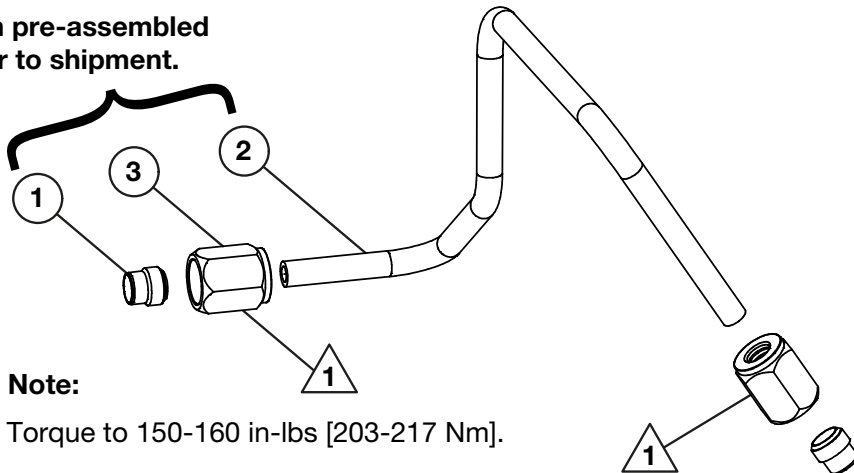

Note:

△ 1 Torque to 150-160 in-lbs [203-217 Nm].

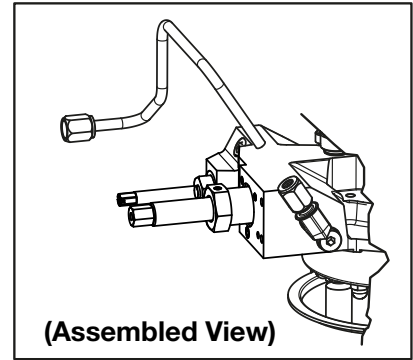

(Assembled View)

Repair Parts List for Figure 5A

Item	Part Number	Qty.	Description
1	CU421096	1	Ferrule, Ferulok, 0.25 Tube
2	DD7038268	1	Tube, Flareless, A Port
3	F100093-21	1	Nut, Ferulok, 7/16-20 THD, 0.25

Note: Flareless Tube Kit - A Port DD7038268SR includes all items listed in the table above.

Figure 5B - Motor Replacement Kit: DD6770259K

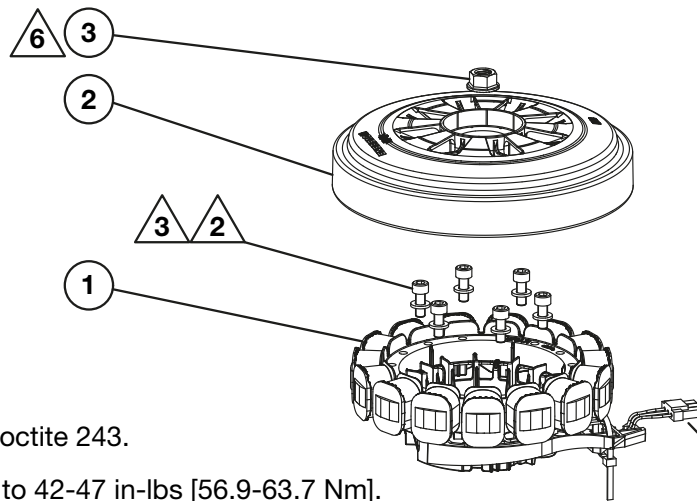

Notes:

△ 2 Apply Loctite 243.

△ 3 Torque to 42-47 in-lbs [56.9-63.7 Nm].

△ 6 Torque to 100-120 in-lbs [11-14 Nm].

See Figure 13 for electrical wire connections.

Repair Parts List for Figure 5B

Item	Part Number	Qty.	Description
1	DD6770259	1	Motor Stator Assembly
2	DD6771257	1	Motor Rotor
3	DD7003021	1	Nut, Flange M10 x 1.25, With Counterbore

Note: Motor Replacement Kit DD6770259K includes all items listed in the table above.

Figure 5C - Bulkhead Fitting Kit: DD7105093K

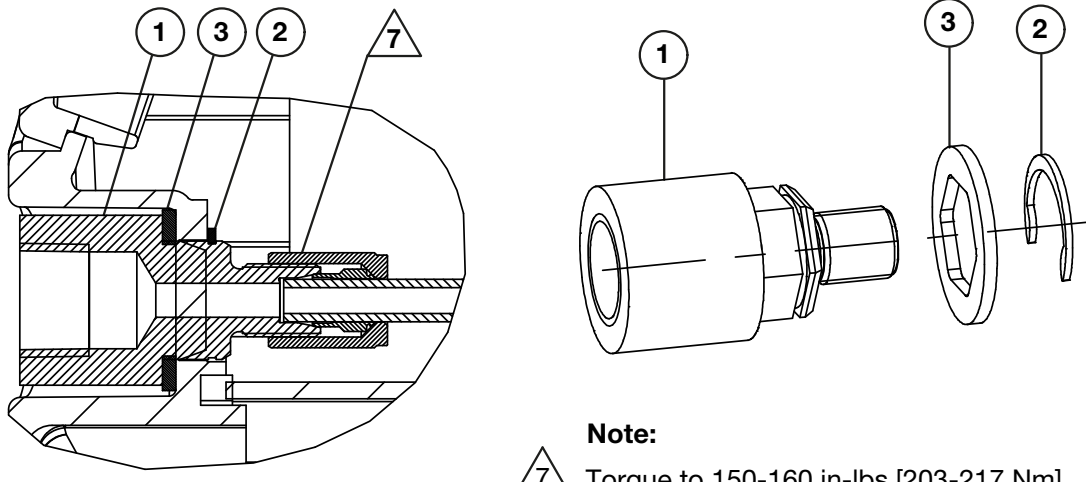

Repair Parts List for Figure 5C			
Item	Part Number	Qty.	Description
1	DD7105093	1	Bulkhead Fitting, 3/8" NPT x 0.25 Flareless
2	DD7106044	1	Retaining Ring, External, 13/16" Shaft
3	DD7447037	1	Gasket, Bulkead, E-Pulse

Note: Bulkhead Fitting Kit DD7105093K includes all items listed in the table above.

Figure 6 - Reservoir and End Cap Assembly

Notes:

1 Torque to 60-70 in-lbs [6.8-7.9 Nm].

2 Torque to 106-133 in-lbs [12-15 Nm].

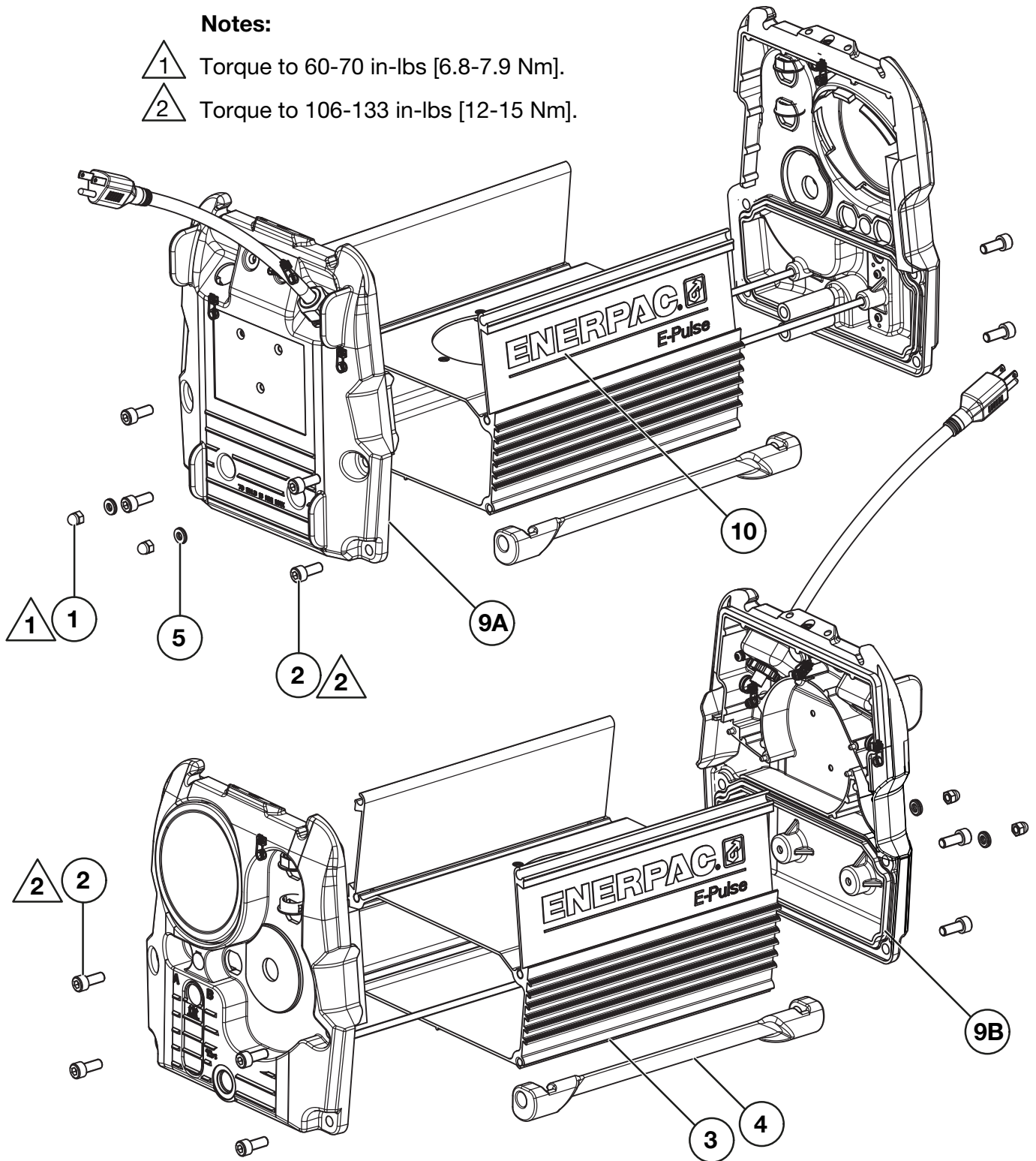

Repair Parts List for Figure 6			
Item	Part Number	Qty.	Description
1	CAE1060055-1A	2	Acorn Nut M6
2	CBE821028-1A	8	Screw-SHCS, Hex, M8 x 1.25 x 20, 8.8, Zinc
3	DD6788025-P03	1	Reservoir, Machined, 1 Gal, Yellow
4	DD6795870	2	Foot, Rubber
5	DD7164108	2	Washer, Rubber Sealing, M6
9A	See Figure 8	1	Endcap Assembly, Front
9B	See Figure 7	1	Endcap Assembly, Rear
10	DD7290026	2	Decal, Enerpac Logo, Die-cut
---	S3037	3	Gasket (<i>See Figure 5, item 19</i>)

Figure 7 - Rear End Cap Assembly

Notes:

- 1 Torque to 25-30 in-lbs [2.8-3.4 Nm].
- 4 Remove adhesive backing before installation.
- 5 Remove nut. Insert potentiometer through endcap and reinstall nut. Torque to 8-10 in-lb [0.9-1.1 Nm].

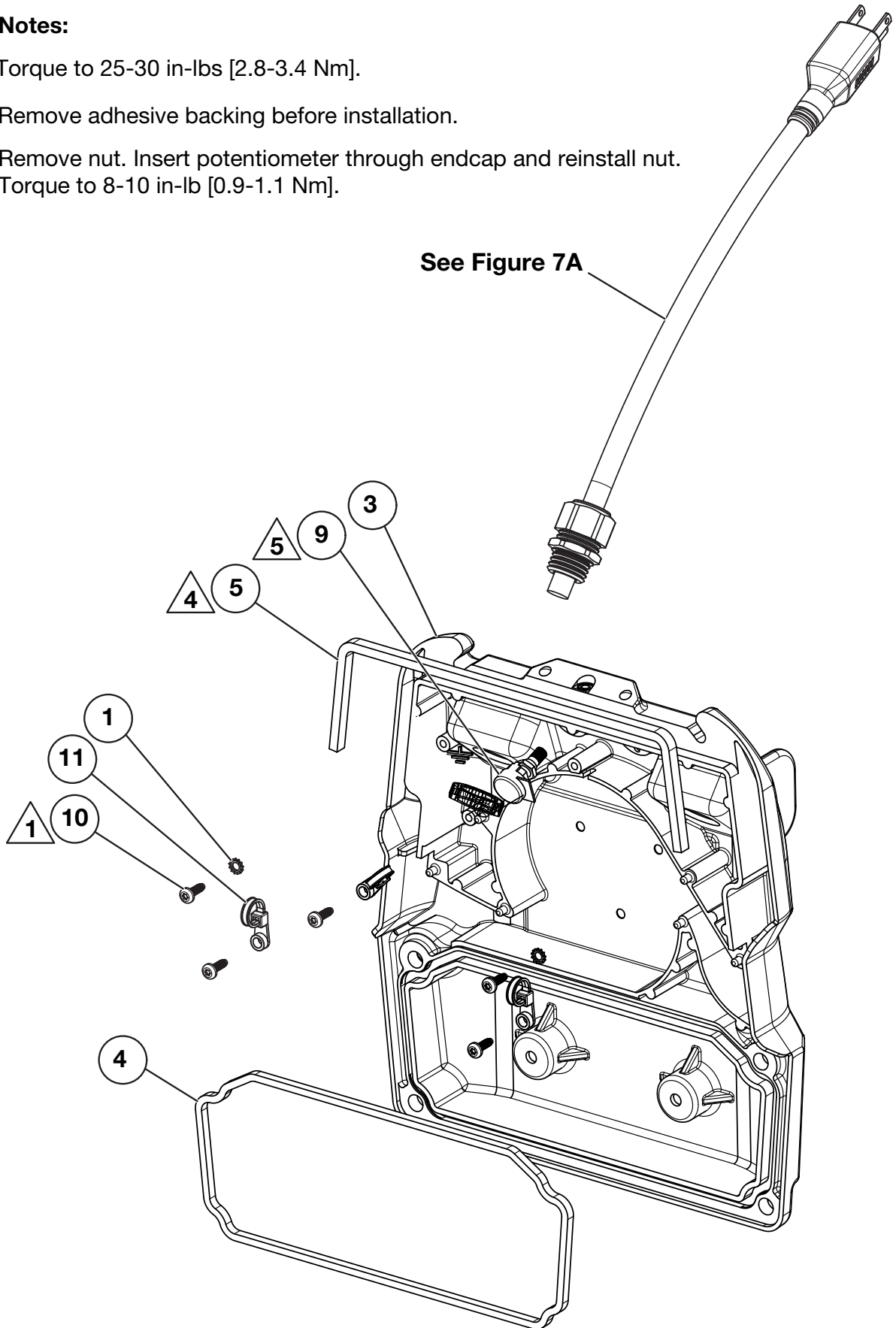

Repair Parts List for Figure 7			
Item	Part Number	Qty.	Description
1	CCE1040108-7A	2	Lock Washer, External Tooth For M4
3	DD6786020	1	End Cap, Rear, Machined, Black
4	DD7017037	1	Gasket, Endcap
5	DD7030037	1	Gasket Tape, 3/16" THK x 1/4" W x 12.25" L
9	DD7060960	1	Cable Assembly, Potentiometer
10	DD7328001	5	Screw, Thread Forming, M4 x 12 Long
11	DD7331217	3	Cable Tie, Screw Mount
12	DD7439960	1	Cable Assembly, Power, Motor Controller
13	DD7463118	2	Filter, 20 x 10 x 100

Figure 7A - Power Cord Replacement Kit

Notes:

- ⚠️ 2 Torque to finger tight plus an additional 1/4 turn.
- ⚠️ 3 Power cord varies depending on voltage and region. See parts list for details.

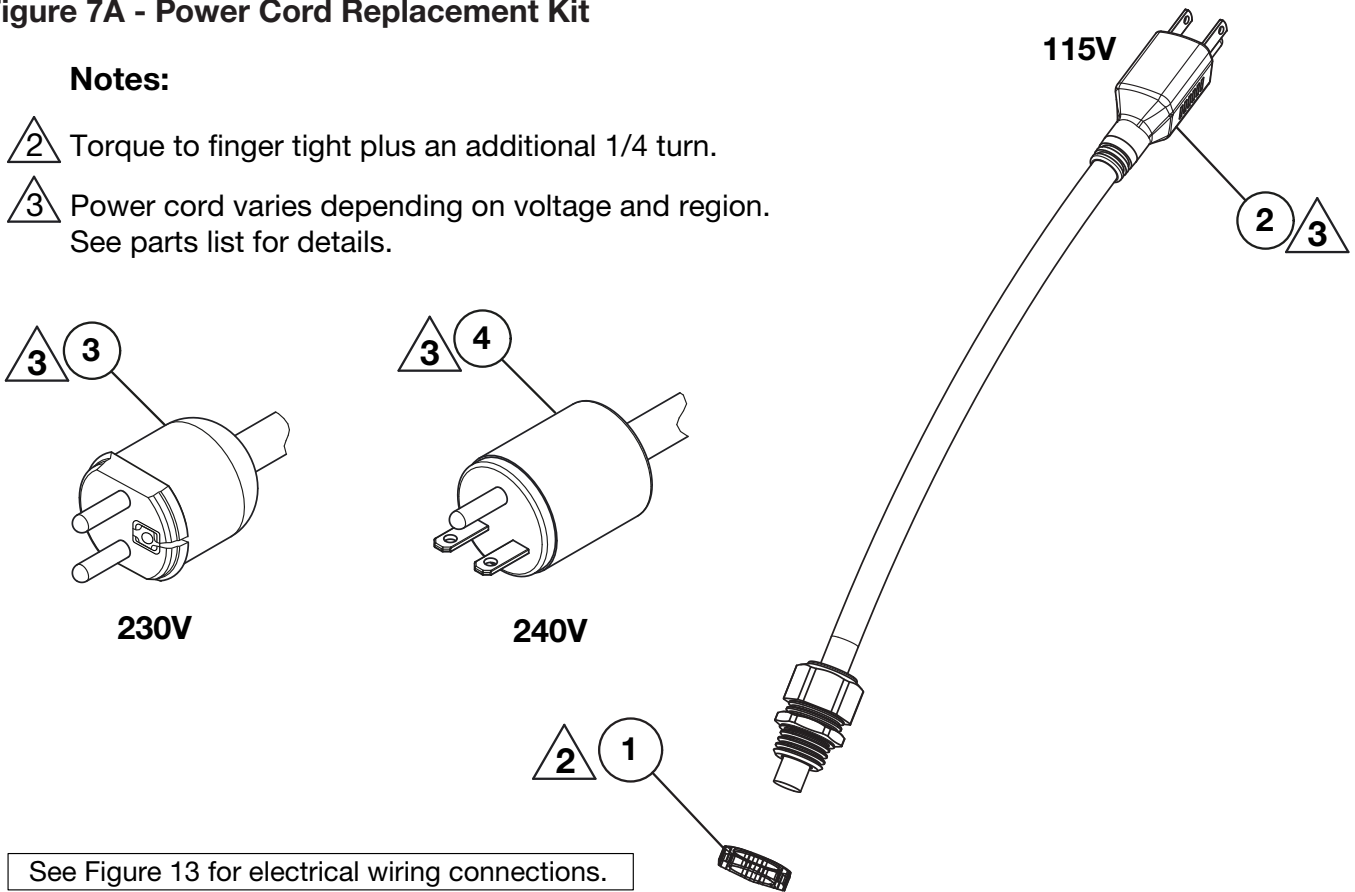

Repair Parts List for Figure 7A			
Item	Part Number	Qty.	Description
1	DC9538021	1	Locking Nut 20mm
2	DD7044960SR	1	Power Cord, 115 VAC, 50/60 Hz, NEMA 5-15 (Model EP3204JB)
3	DD7045960SR	1	Power Cord, 208/230 VAC, 50/60 Hz, NEMA 6-15 (Model EP3204JI)
4	DD7046960SR	1	Power Cord, 208/240 VAC, 50/60 Hz, CEE 7/7 EHUK (Model EP3204JE)

Note: Item 1 NOT included in power cord kits. Order separately.

Figure 8 - Front End Cap Assembly

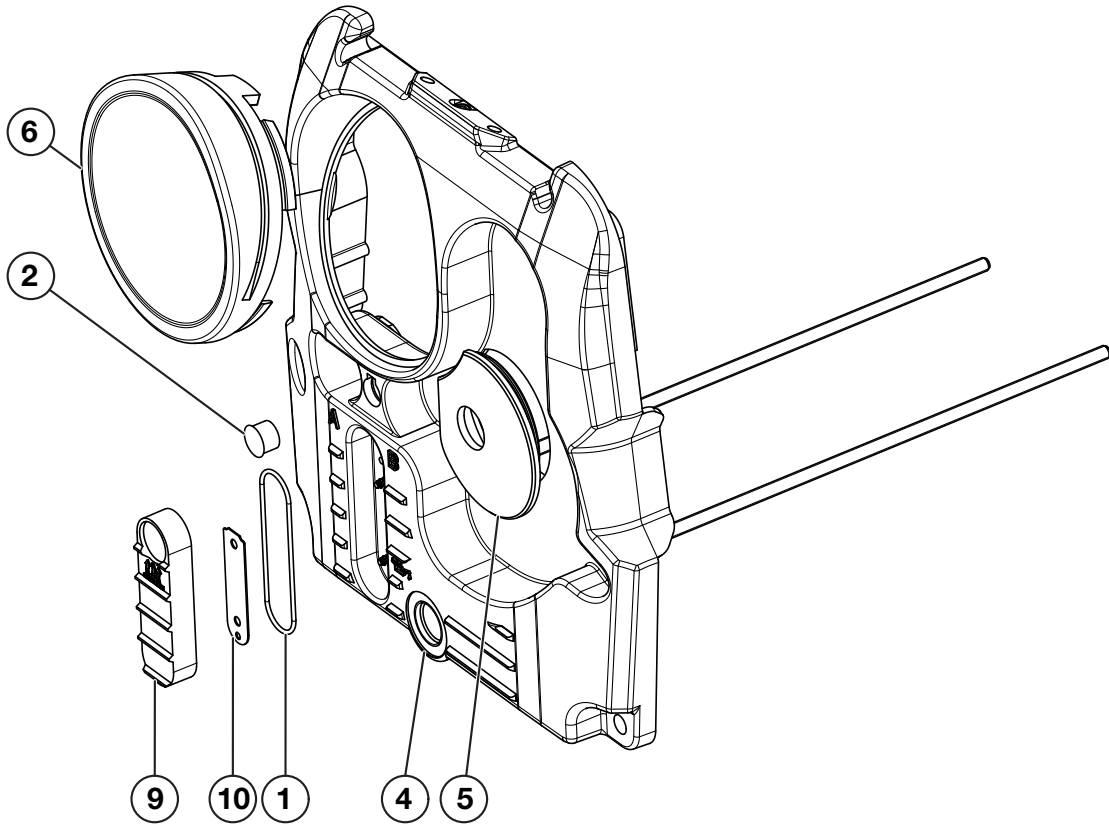

Notes:

- ▲1 Apply Loctite 2760.
- ▲2 Torque to 8-10 in-lbs [0.9-1.1 Nm].
- ▲4 Install to full depth.
- ▲5 Torque to 25-30 in-lbs [2.8-3.4 Nm].

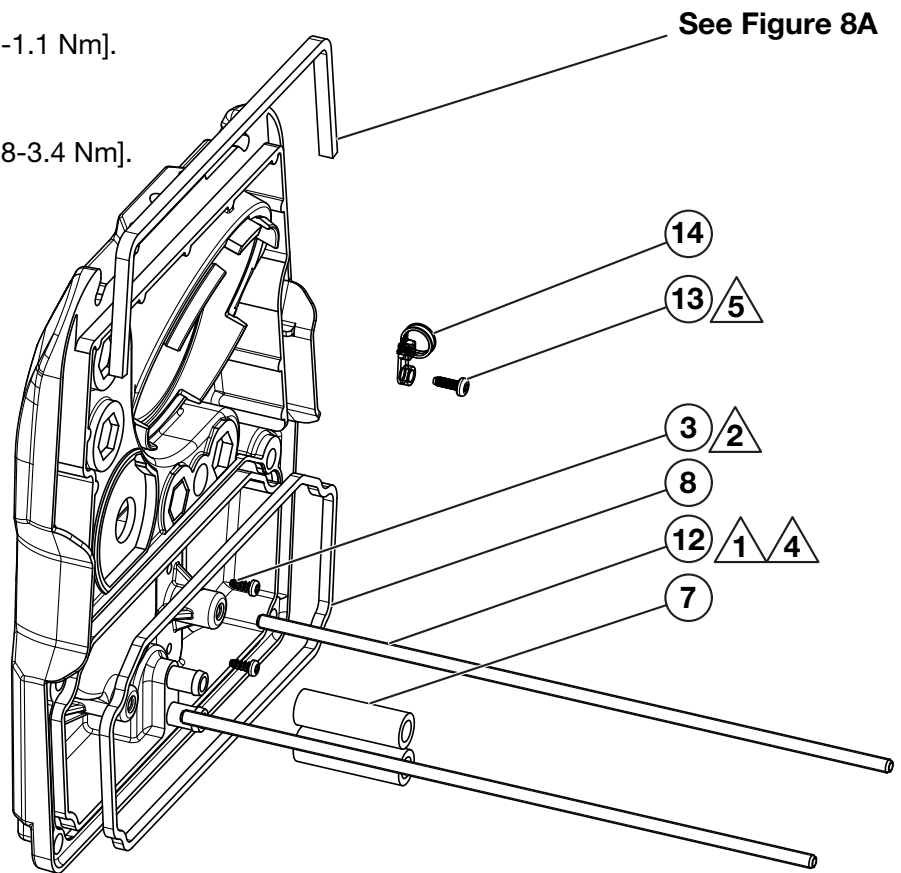

Repair Parts List for Figure 8			
Item	Part Number	Qty.	Description
1	B1240503	1	O-Ring, 2-1/8 ID, 0.070 W
2	DC8228009	1	Dome Plug 1/2"
3	DD3883028	2	Screw M4 x 10 Thread FRM, TRX
4	DD6784020	1	End Cap, Front, Machined, Black
5	DD6990808	1	Grommet, Valve, Rubber, 4/3m
6	DD6997020	1	Cap, Gauge
7	DD7002646	2	Hose, Rubber, 9.52 x 15.88 x 50L
8	DD7017037	1	Gasket, Endcap
9	DD7021223	1	Sight Gage
10	DD7022225	1	Insert, Sight Gage
12	DD7107305	2	Threaded Rod, M6 x 1.0 x 300 Long
13	DD7328001	1	Screw, Thread Forming, M4 x 12 Long
14	DD7331217	1	Cable Tie, Screw Mount

Figure 8A - Water Ingress Seal Kit: EPWISK1

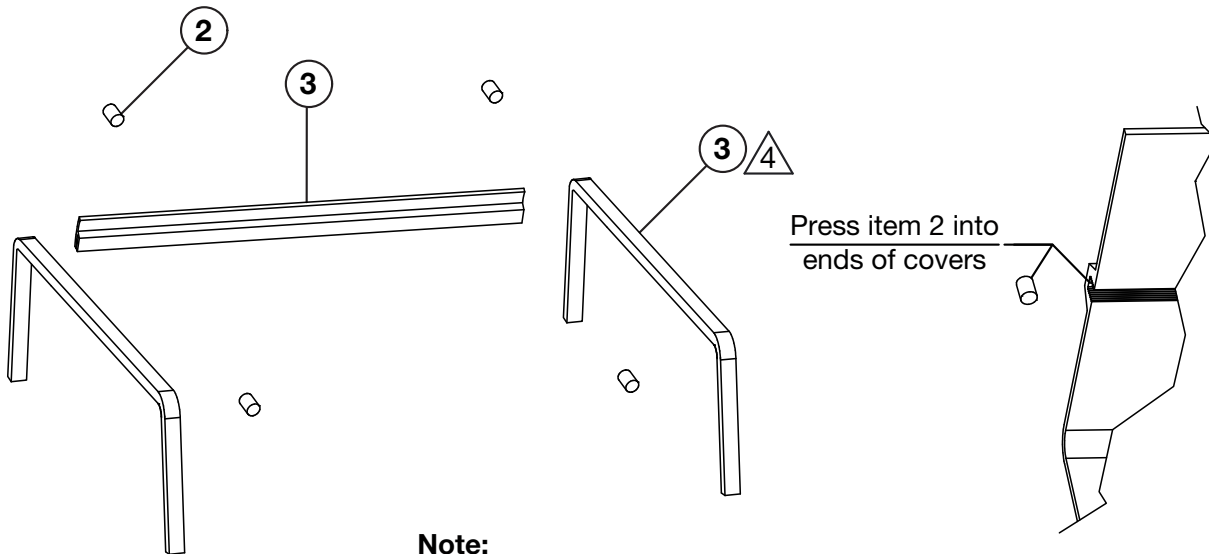

Note:
 ⚠ Remove adhesive backing before installation.

Repair Parts List for Figure 8A			
Item	Part Number	Qty.	Description
1	DD7448037	1	Lip Seal, E-Pulse
2	DD7462037	4	Gasket, 4.0mm Dia x 5.50mm L Cord Stock
3	DD7030037	1	Gasket Tape, 3/16" THK x 1/4" W x 12.25" L

Note: Water Ingress Seal Kit EPWISK1 includes all items listed in the table above.

Figure 9 - Housing Assembly

Notes:

- ① Apply grease to aid assembly of housing to manifold.
- ② Torque to 7-9 ft-lbs [9.4-12.2 Nm].
- ④ Apply Loctite 2760, and torque to 55-65 in-lbs [6.2-7.3 Nm].
- ⑤ Install flush with top surface, after adding oil.
- ⑦ Orient as shown.

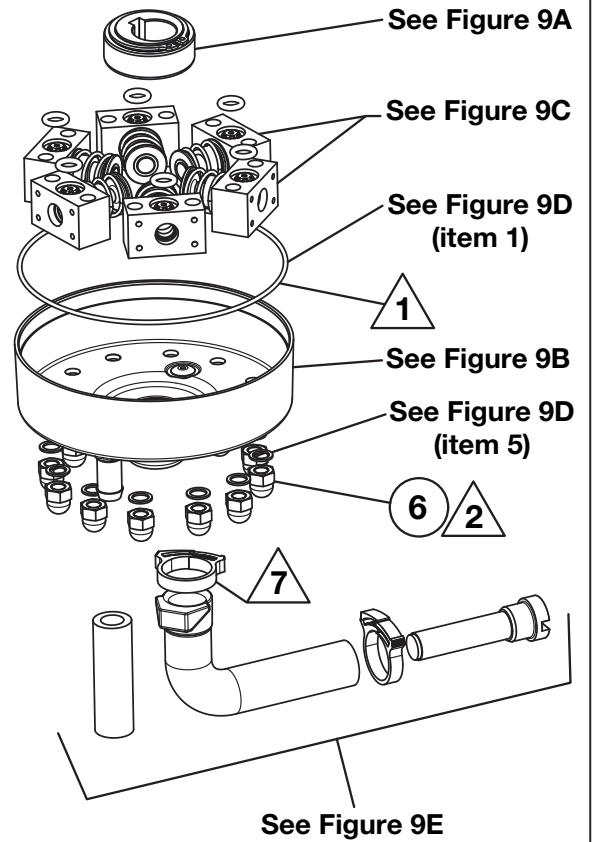
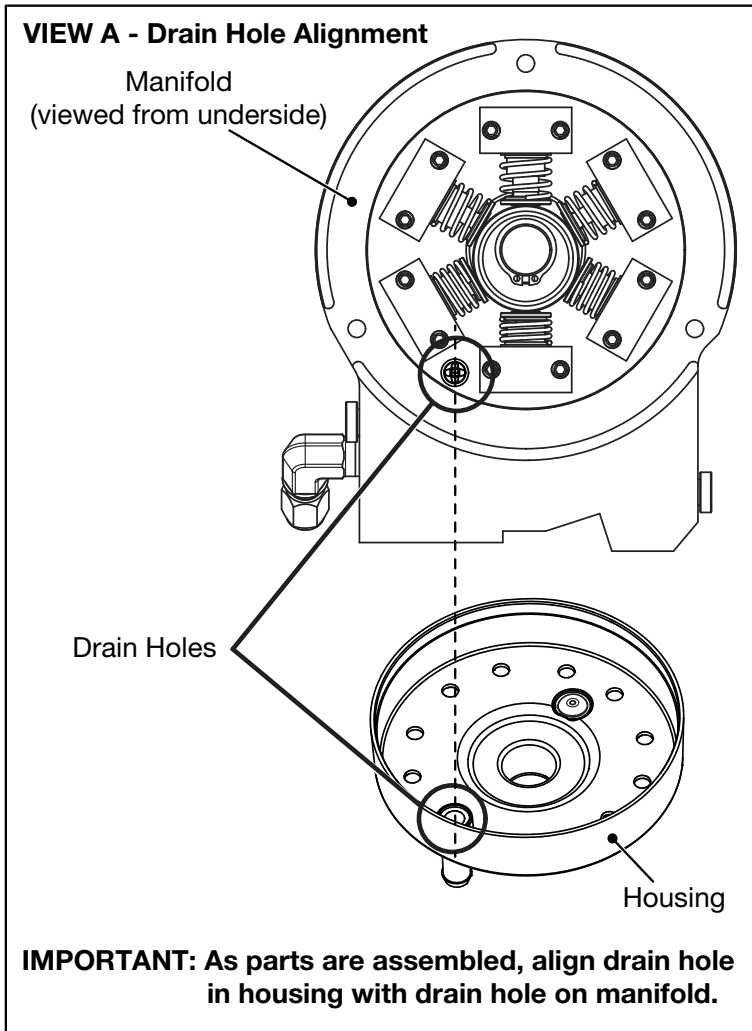
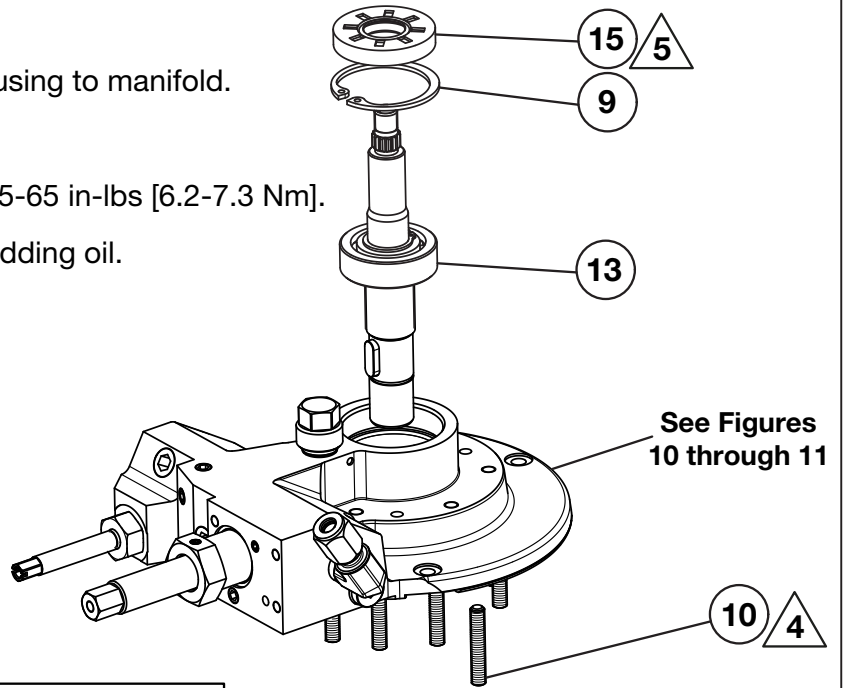

Repair Parts List for Figure 9			
Item	Part Number	Qty.	Description
6	CAE1060055-1A	12	Acorn Nut M6
9	CCA1042044-1C	1	Wiper Ring
10	CCA627028-5A	12	Screw-Set, Flat, HS, M6 x 1 x 35, 45H, Plain
13	DD7004900	1	Shaft, Sub Assembly
15	DD7008476	1	Seal, Rotary 17 x 42 x 7

Figure 9A - Eccentric Kit: DD72575375SR

Eccentric is shipped pre-assembled. Parts shown disassembled for reference purposes only.

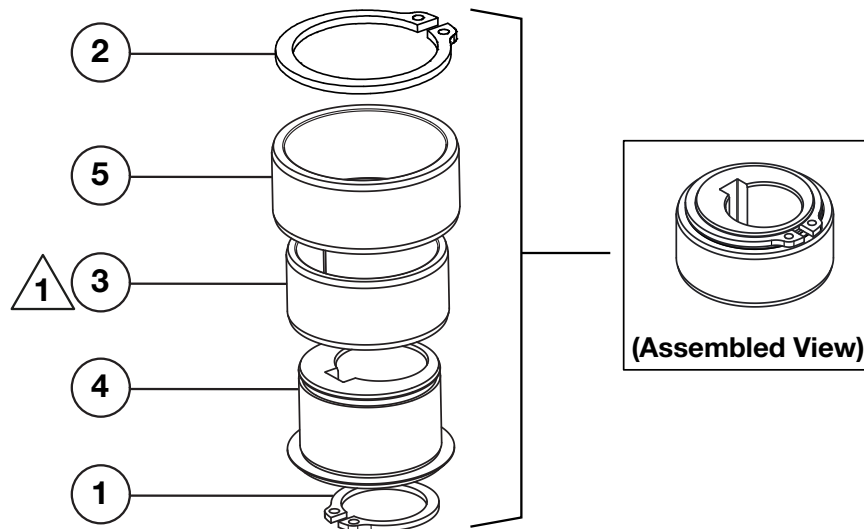

Note:

1 Press fit item 13 onto item 21 with 1100 psi on 10 ton press.

Repair Parts List for Figure 9A			
Item	Part Number	Qty.	Description
1	CCA1018044-1A	1	Retaining Ring-Ext., 18mm, STL
2	CCA1028044-1A	1	Retaining Ring-Ext., 28mm, STL
3	DD6779350	1	Bearing, Sleeve, 28 x 32 x 15
4	DD7257537	1	Eccentric (3mm Offset)
5	DD7261350	1	Race, Cam

Note: Eccentric Kit DD72575375SR includes all items listed in the table above (pre-assembled).

Figure 9B - Pump Housing Kit: DD7005900SR

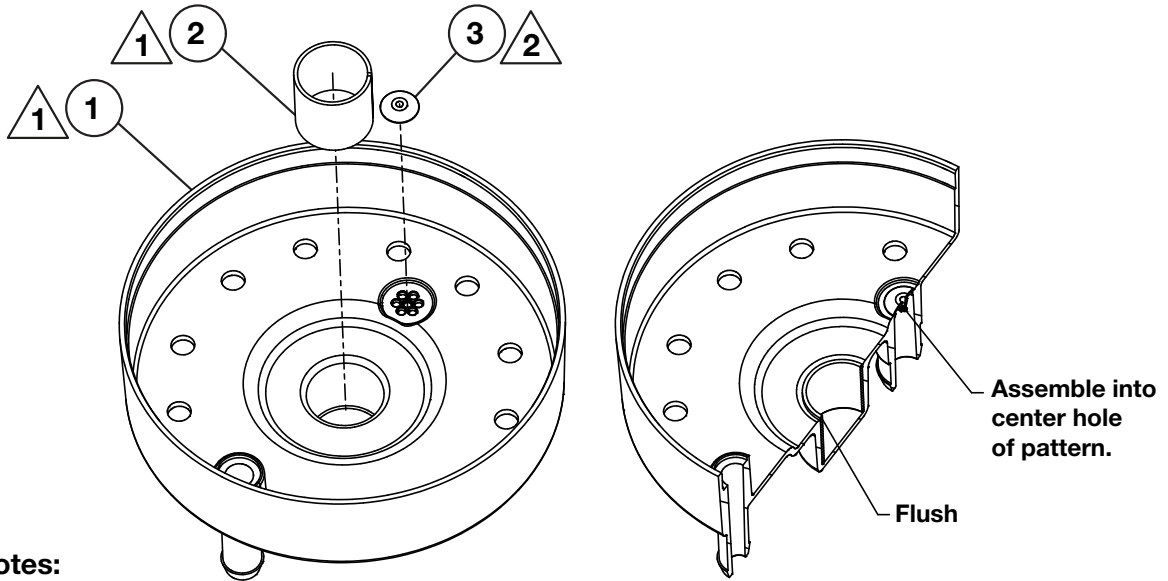

Notes:

- ① Press item 1 and 2 together flush as shown. 400 psi using 10 ton press.
- ② Press using finger.

Repair Parts List for Figure 9B			
Item	Part Number	Qty.	Description
1	DD6762001	1	Housing, Pump
2	DD6775039	1	Bushing, 18 x 20 x 20, Housing
3	DD6965661	1	Inlet Check Umbrella Valve, Housing
Note: Pump Housing Kit DD7005900SR includes all items listed in the table above.			

Figure 9C - Piston Block Assembly Kits: DD7230900SR & DD7231900SR

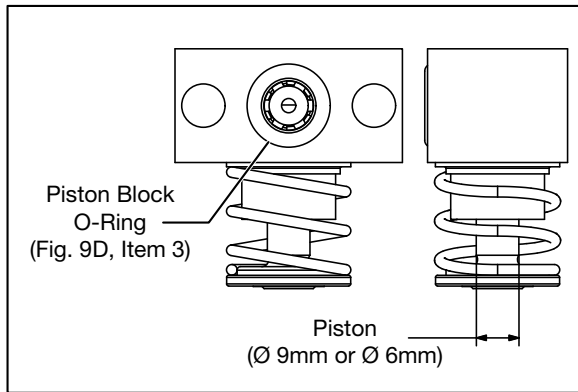

(Pump manifold viewed from below)

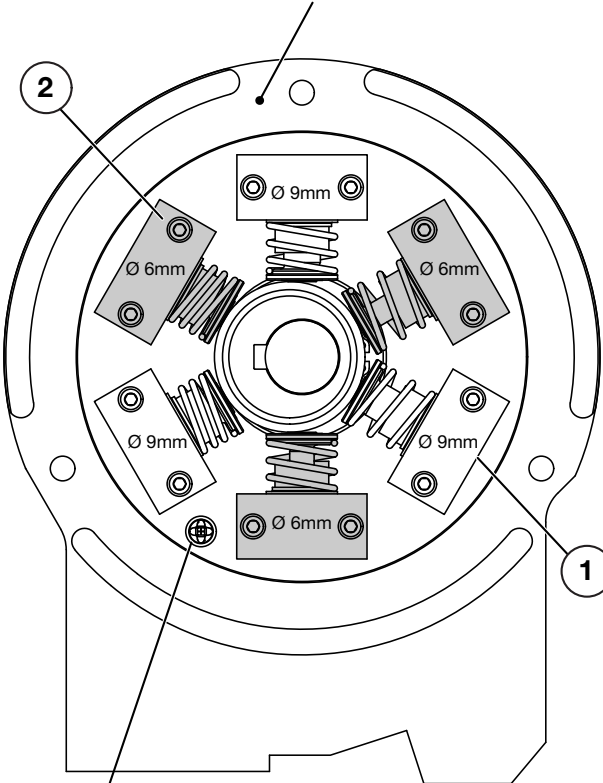

Oil Drain Hole

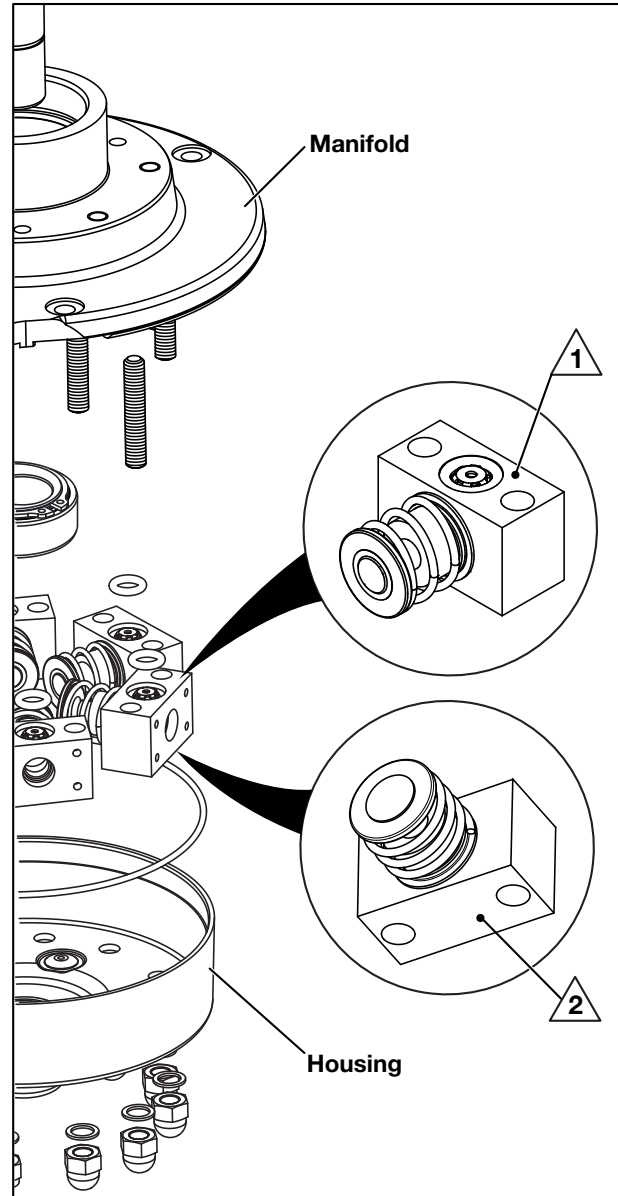

IMPORTANT:

- 1 Side with oil port must face toward manifold.
- 2 Flat side must face toward housing.

- Each piston block kit includes 3 piston blocks and 3 piston block O-Rings (Figure 9D, item 3).
- It is recommended that new O-Rings be installed on ALL piston blocks, even if only some of the piston blocks are being replaced.
- A complete set of O-Rings and gaskets is provided in the piston block seal kit (order separately - See Figure 9D).
- Refer to Figures 9, 9A, 9B and 9D for torque values and additional assembly instructions.

Repair Parts List for Figure 9C

Item	Part Number	Qty.	Description
1	DD7230900SR	3	Piston Block, Ø 9mm
2	DD7231900SR	3	Piston Block, Ø 6mm

Figure 9D - Piston Block Seal Kit: EPPBSK

This kit does not contain manifold gasket DD7319037. Order separately if needed. See Figure 5, item 15.

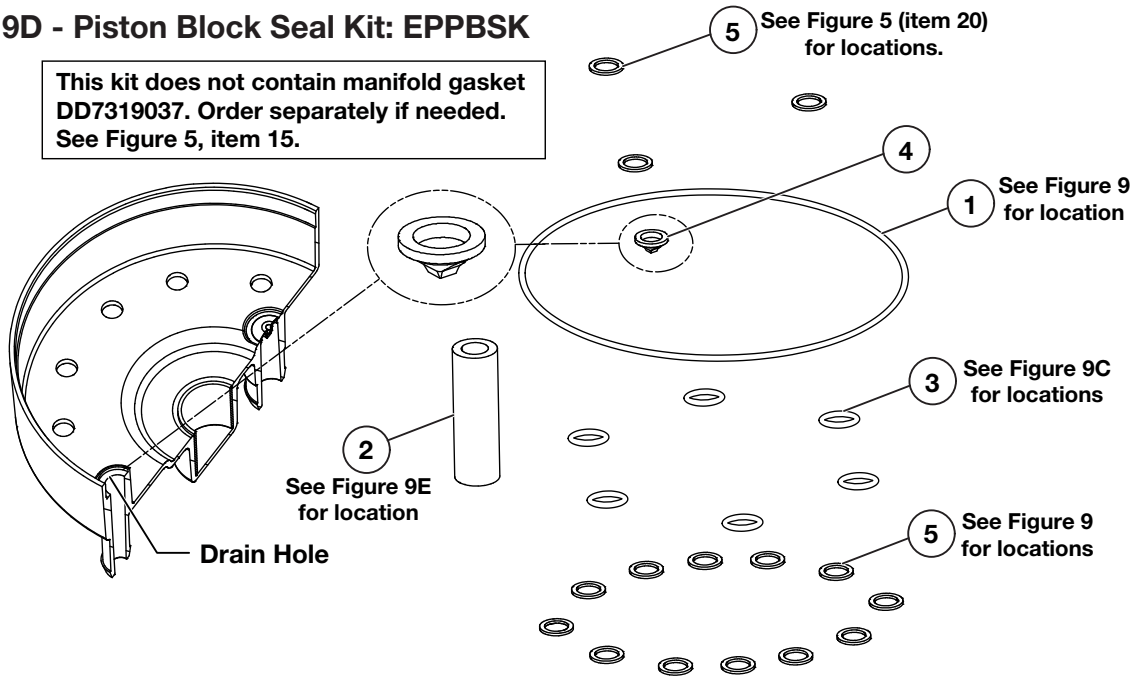

Repair Parts List for Figure 9D

Item	Part Number	Qty.	Description
1	B1400503	1	O-Ring 4-1/4", 4-3/8", 1/16", NBR, 70 Duro
2	DD7002646	1	Hose Rubber, 9.52 x 15.88 x 50L
3	DD7616903	6	O-Ring, Piston Block, Metric, 8 x 2, NBR, 90 Duro
4	DD7603101	1	Valve Mini, Cross-Slit
5	S3037	12	Gasket

Note: Piston Block Seal Kit EPPBSK includes all items listed in the table above.

Figure 9E - Intake Suction Filter Kit: DD7176118K

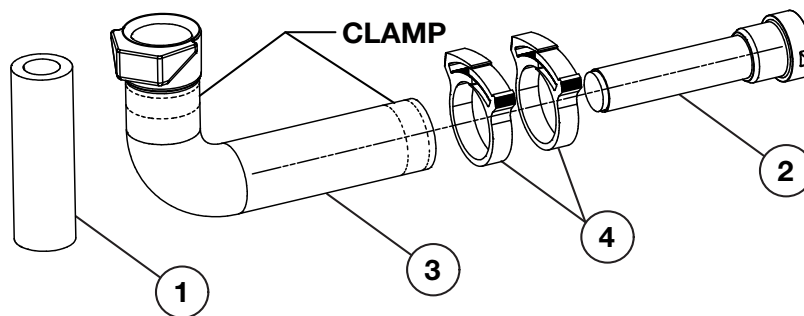

Repair Parts List for Figure 9E

Item	Part Number	Qty.	Description
1	DD7002646	1	Hose, Rubber, 9.52 x 15.88 x 50L
2	DD7176118	1	Filter, In Line
3	DD7177268	1	Tube, Inlet Filter
4	DD7222299	2	Clamp, Inlet Filter

Note: Intake Suction Filter Kit DD7176118K includes all items listed in the table above.

Figure 10 - Direct Drive Pump Assembly

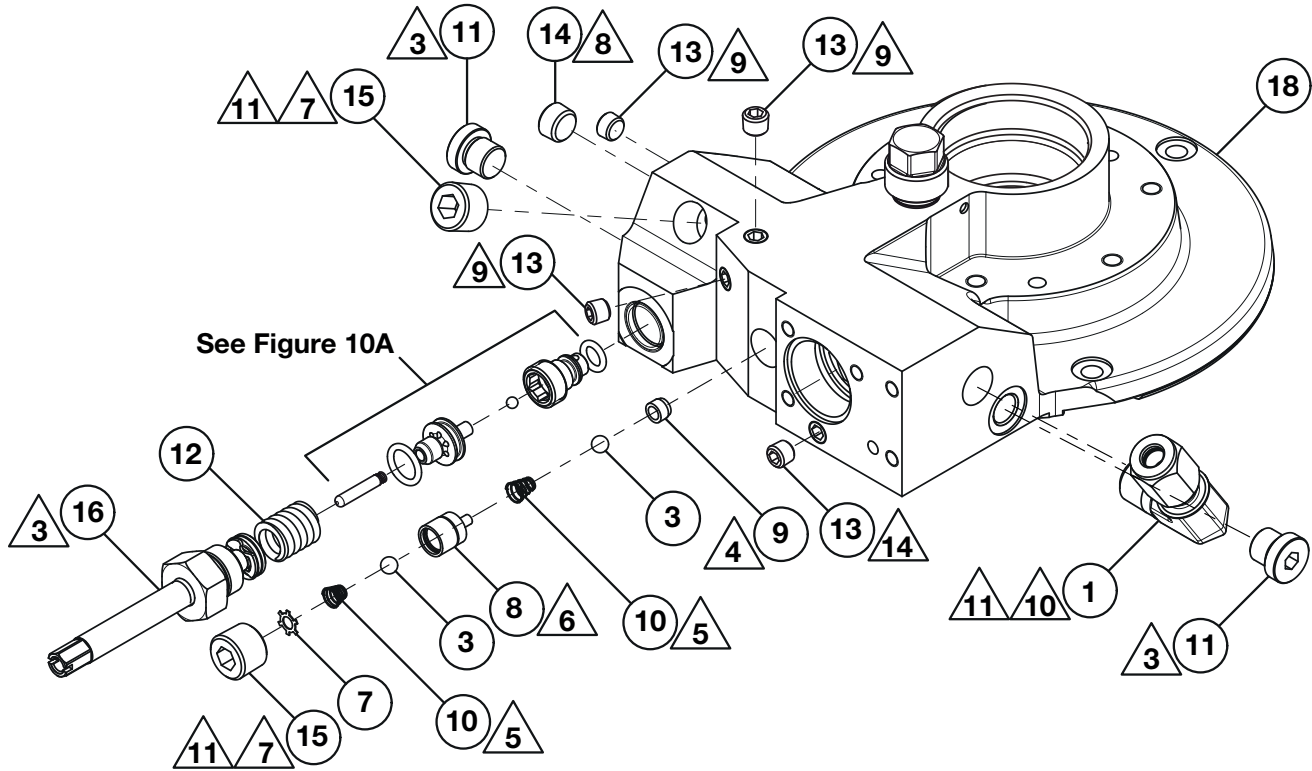

Notes:

- 3** Triangle: Torque to 13-16 ft-lbs [18-22 Nm].
- 4** Triangle: Coin at 300 psi on 10 ton press after assembly, Press into manifold 500 psi on 10 ton press.
- 5** Triangle: Observe direction.
- 6** Triangle: Press fit at 1100 psi on 10 ton press.
- 7** Triangle: Torque to 28-34 ft-lbs [38-46 Nm].
- 8** Triangle: Torque to 10-12 ft-lbs [14-16 Nm].
- 9** Triangle: Torque to 6-8 ft-lbs [8-11 Nm].
- 10** Triangle: Torque to orientation, 28 ft-lbs [40 Nm] min.
- 11** Triangle: Apply Teflon tape to NPTF thread.
- 14** Triangle: Torque to below flush, 7 ft-lbs [9.5 Nm] min.

Repair Parts List for Figure 10			
Item	Part Number	Qty.	Description
1	A8033096	1	Elbow Fitting 0.25 NPTF x 0.25 Flareless
3	B1005016	2	Ball, 3/16 Dia.
6	BA0210059	1	Dowel Pin 1/8" x 5/8" Long
7	BSS5356D	1	Retaining Ring
8	BSS5357D	1	Seat Piston Upper
9	BSS5358D	1	Seat Piston Lower
10	BSS5809D	2	Conical Spring
11	CS236006	2	Plug G1/8 Steel W/Seal

Repair Parts List for Figure 10 (Continued)			
Item	Part Number	Qty.	Description
12	DA3282110	1	Spring-Comp., 320 lbs/in
13	DC6792245	4	PTF-SAE Flush Plug 0.062
14	DC6793245	1	PTF-SAE Flush Plug 0.125
15	DC6794245	2	PTF-SAE Flush Plug 0.250
16	DD6778900	1	Plug Asm. UARV
18	DD7052900	1	Direct Drive Pump, DMPE

Figure 10A - Rebuild Kit, User-Adjustable Relief Valve: DD7234290K

**These parts not included in kit.
Refer to Figure 10.**

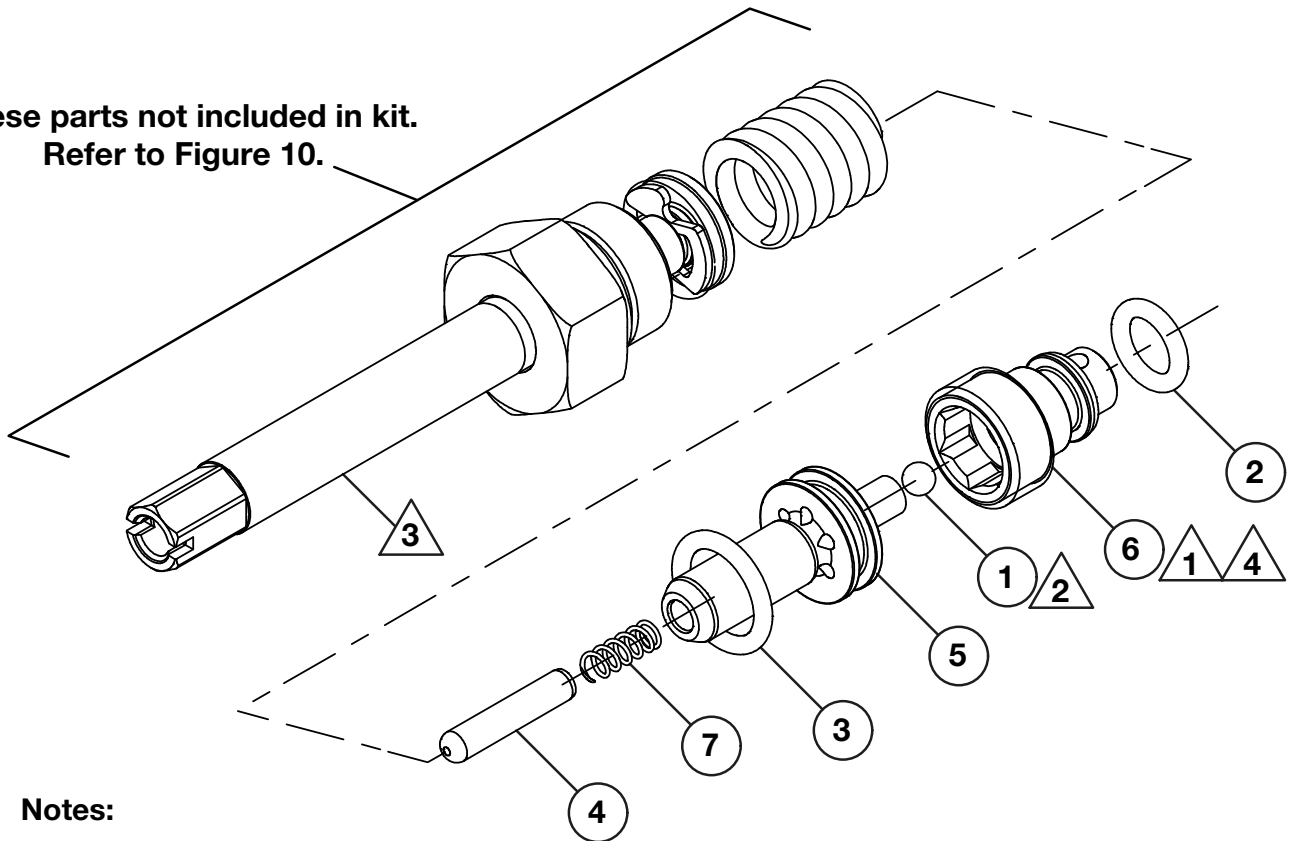

Notes:

- △ 1 Torque to 84-108 in-lbs [9.5-12.2 Nm].
- △ 2 Press fit 150-200 psi on 10 ton press, Item 1 onto item 5.
- △ 3 Torque to 13-16 ft-lbs [18-22 Nm].
- △ 4 Coin 150 psi on 10 ton press.

Repair Parts List for Figure 10A			
Item	Part Number	Qty.	Description
1	B1003016	1	Ball, 0.125 Dia.
2	B1010803	1	O-Ring-1/4", 3/8", 1/16", Disogrin, 92 Duro
3	B1012203	1	O-Ring-3/8", 1/2", 1/16", Viton, 90 Duro
4	BA0210059	1	Dowel Pin 1/8" x 5/8" Long
5	DD6780013	1	Ball Guide
6	DD7234290	1	Ball Seat
7	PA27110	1	Spring-Comp., 8.30 lbs/in

Note: Rebuild Kit, User-Adjustable Relief Valve DD7234290K includes all items listed in the table above.

Figure 11 - 3/2 Manual Valve Assembly

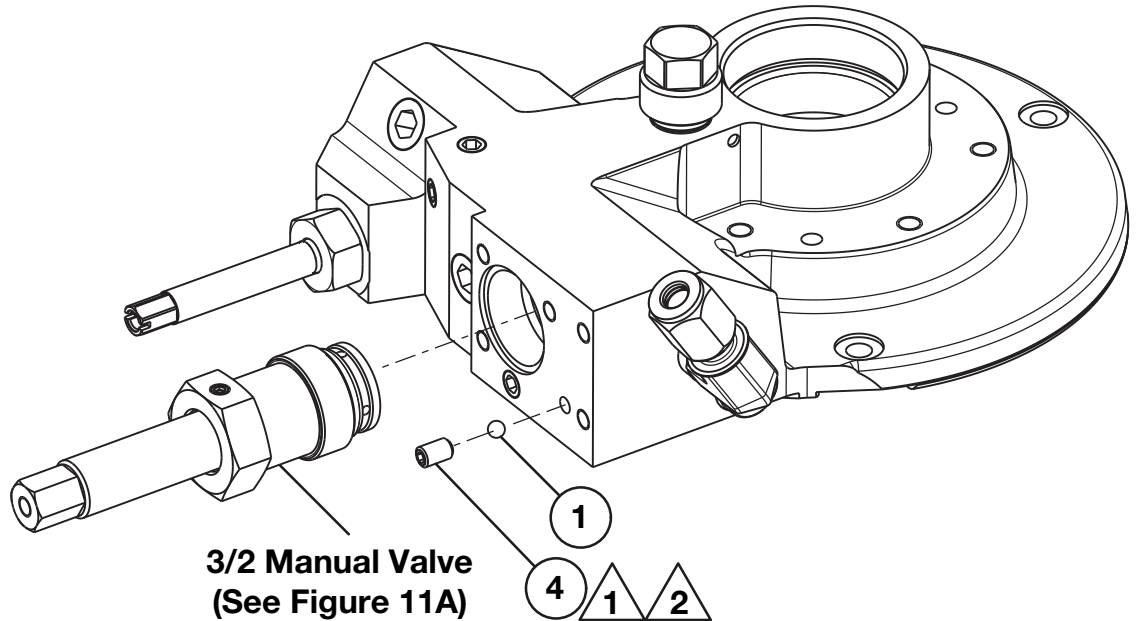

Notes:

△1 Apply Loctite 243.

△2 Torque to 36-48 in-lbs [4.1-5.4 Nm].



Repair Parts List for Figure 11

Item	Part Number	Qty.	Description
1	B1004016	1	Ball, 5/32 Dia.
4	CCA513028-5A	1	Screw-Set, Flat, HS, M5 x 0.8 x 8, 45H, Plain

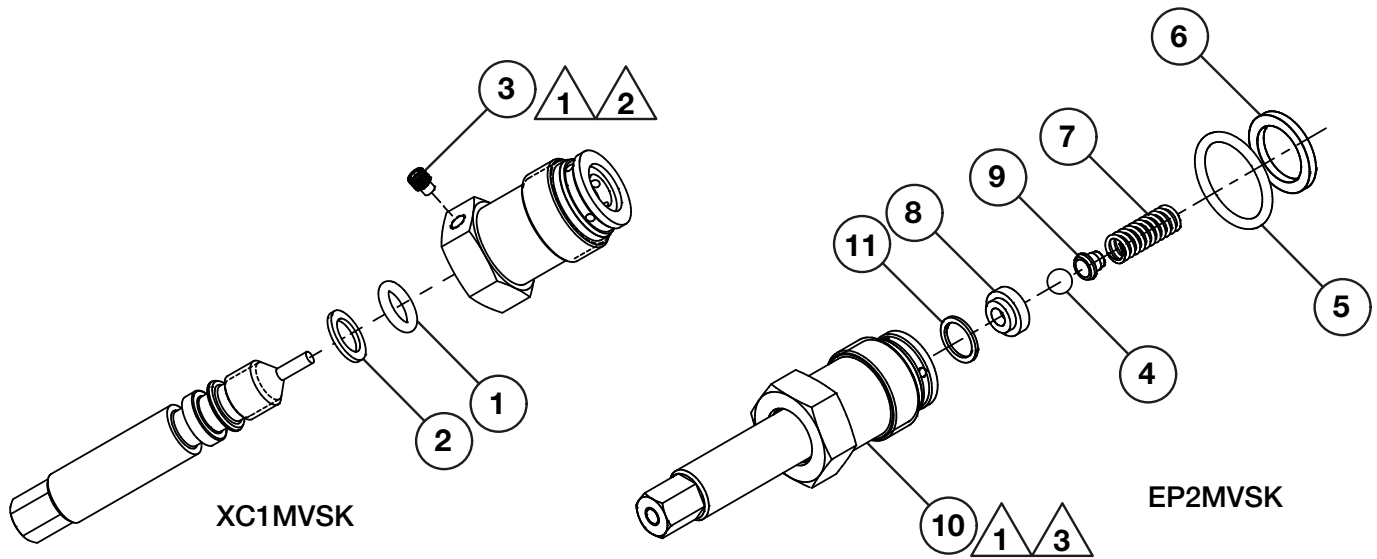
Figure 11A - 3/2 Manual Valve Kits: EP2MVSK and XC1MVSK



Notes:

-  Apply Loctite 243.
-  Torque to 21-26 in-lbs [2.4-3.0 Nm].
-  Torque to 90-95 in-lbs [122-129 Nm].

- Valve replacement kit XC1MVSK includes all items shown (1 through 11).
- Valve rebuild seal kit EP2MVSK includes all items EXCEPT item 10.
- Reuse or order parts not included.

Repair Parts List for Figure 11A			
Item	Part Number	Qty.	Description
1	B1110203	1	O-Ring 3/8", 9/16", 3/32", Viton, 90 Duro
2	B1110564	1	Back Up, Teflon
3	DD3400027	1	10-32 x 0.25 LG Set Screw, Long PT
4	B1007016	1	Ball, 1/4 Dia.
5	B1118903	1	O-Ring 7/8", 1-1/16", 3/32", NBR, 90 Duro
6	CL344167	1	Gasket
7	DC10140110	1	Spring Compression
8	DC7305290	1	Seat
9	DC7309013	1	Ball Guide
10	DD3399900	1	3/2 Manual Valve Assembly, XC
11	P20037	1	Gasket, Valve Plug

Figure 12 - Hydraulic Schematic Diagram

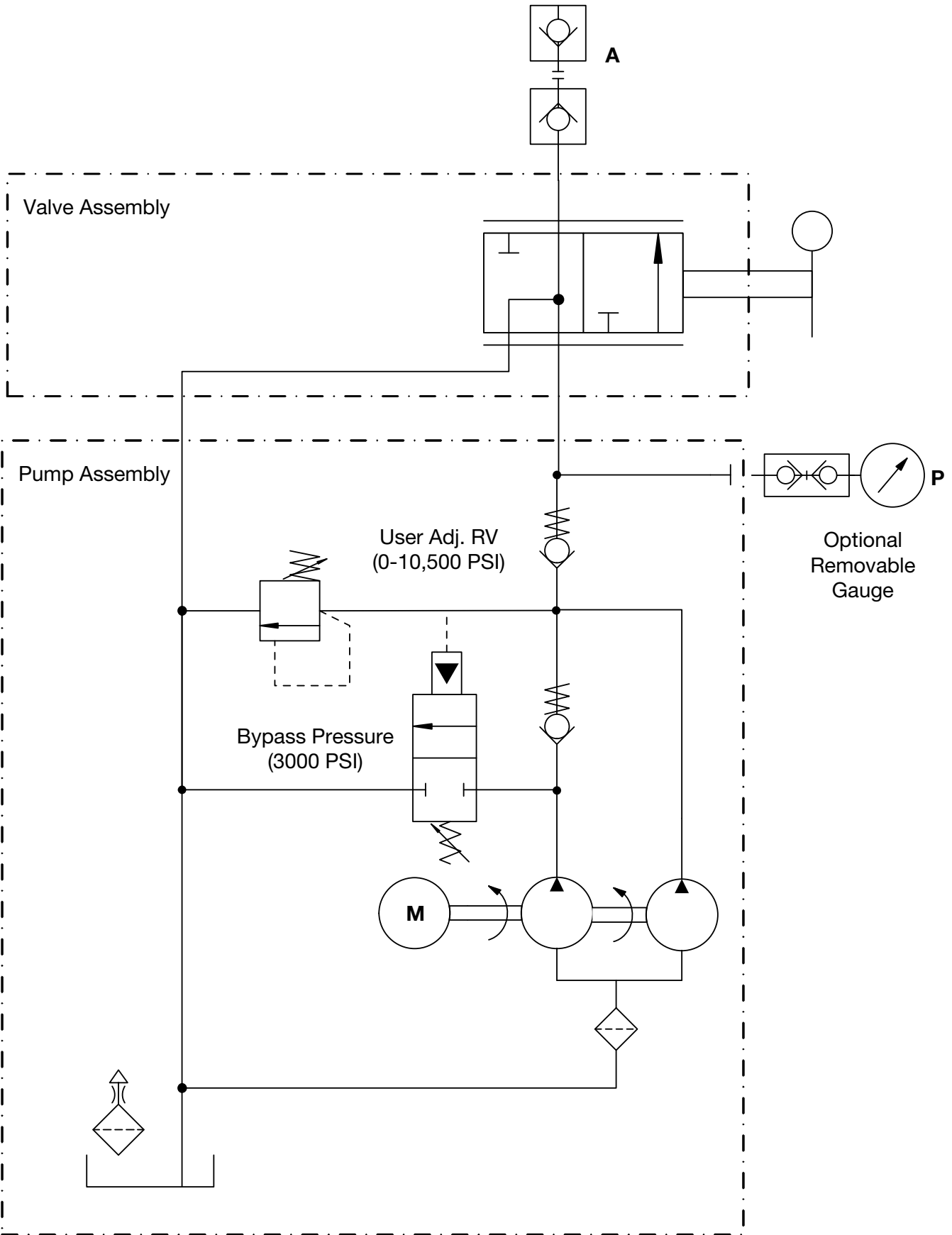

Figure 13 - Electrical Wiring Diagram

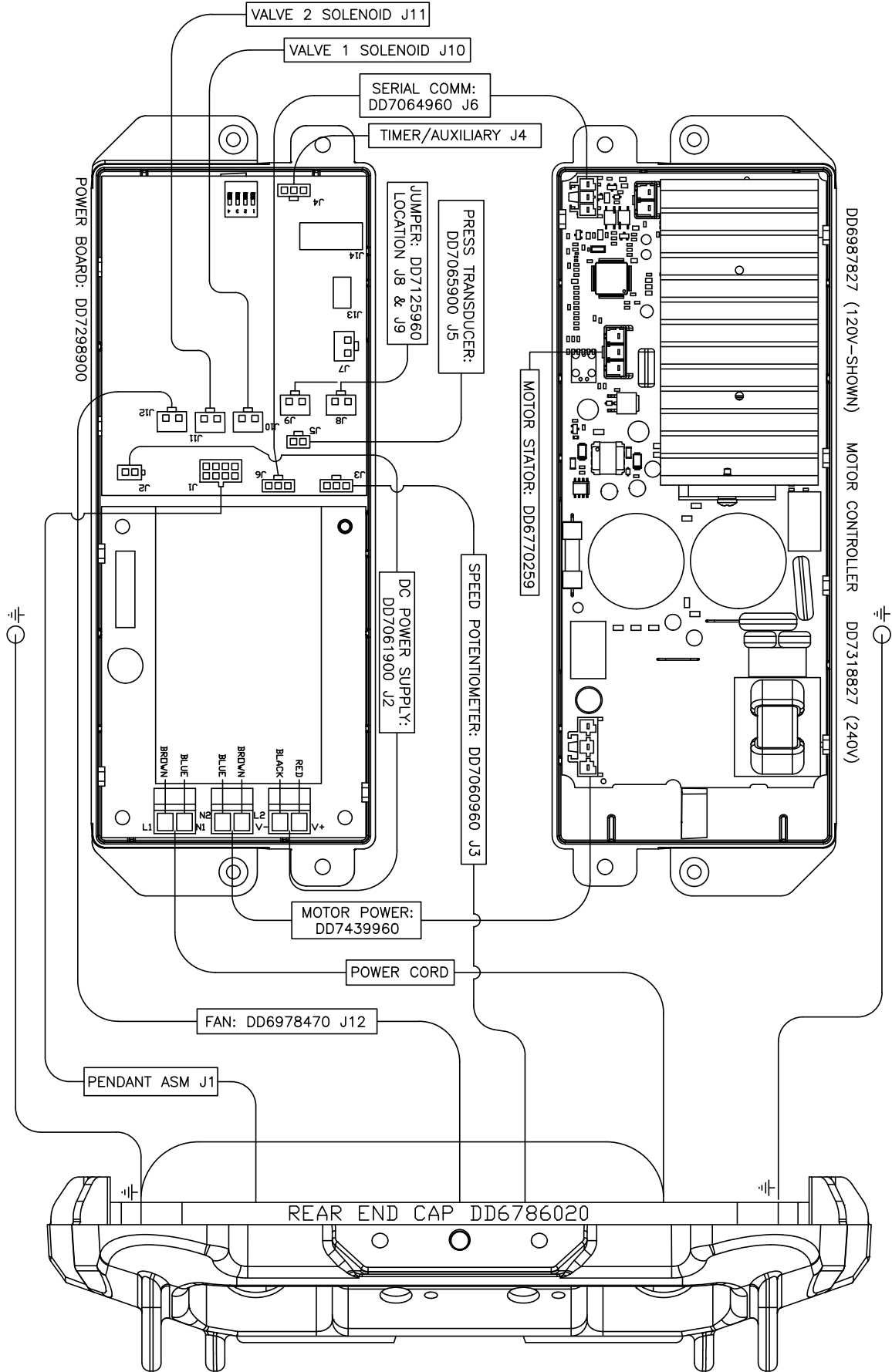
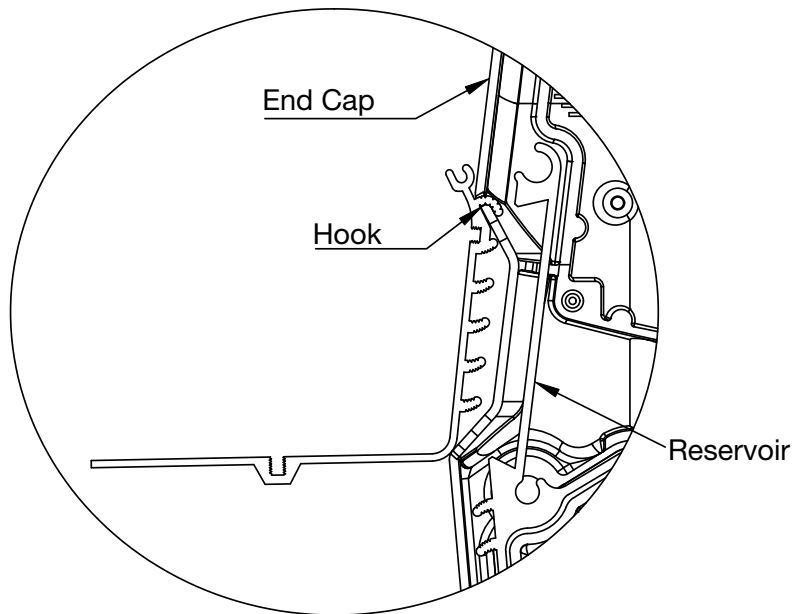
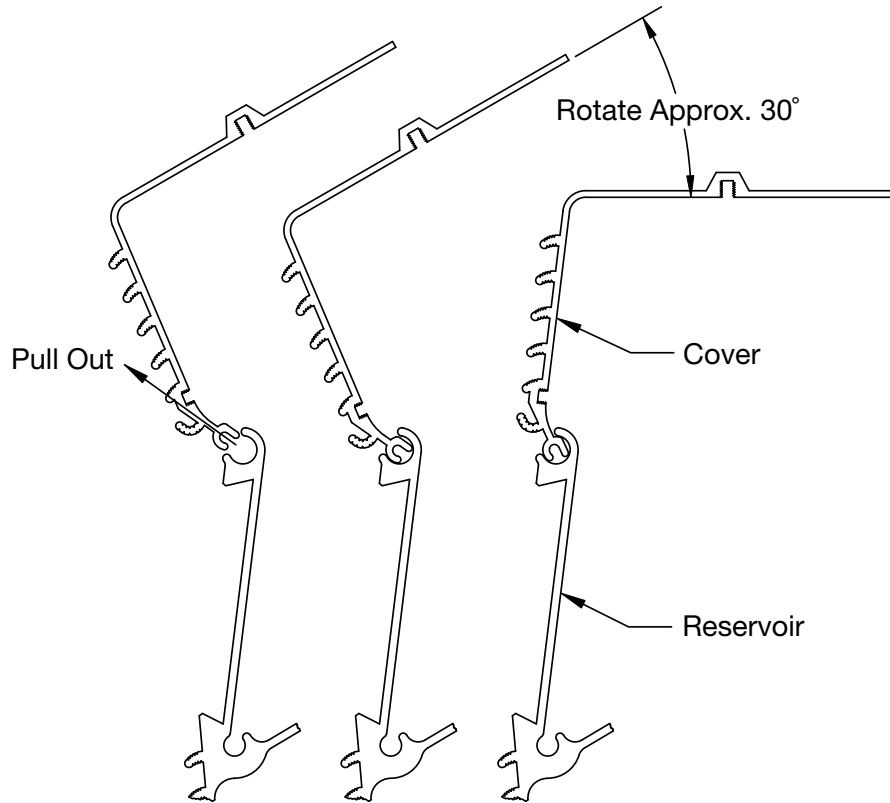

Figure 14 - Pump Cover Removal/Installation Instructions



Removal/installation instructions:

1. Remove 2 pump handle screws and washers.
2. Remove pump handle.
3. Open cover and remove wire connections.
4. Rotate cover approximately 30° from closed position.
5. Pull cover out as shown.
6. Reverse directions for installation. Refer to wiring diagram (Figure 13) and electrical subassembly diagrams (Figures 3 and 4) for wiring and torques.
7. Torque handle screws to 42-47 in-lbs [4.7-5.3 Nm].

NOTES:

NOTES:

A large rectangular box with a thin black border, containing 18 horizontal lines for writing notes. The lines are evenly spaced and extend across the width of the box, leaving a small margin on either side.

